



Tooling Systems

2016



DIN 69871

Register

ISO 60

MAS 403 BT

DIN 2080

HSK-A

VDI

MORSE

ADAPTORS

SPARE PARTS

TECHNICAL PART

DIN 69871



Toolholders DIN 69871

DIN 69871

ISO 60

MAS 403 BT

DIN 2080

HSK-A

VDI

MORSE

Pre-balanced

G 6,3 15.000 min⁻¹

G 2.5 Fine balancing at extra charge

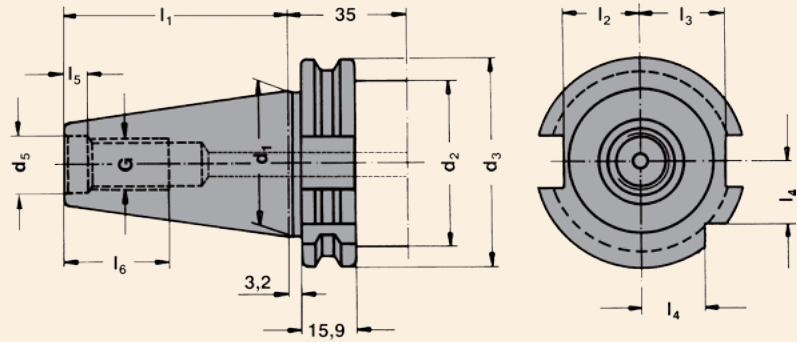

SK	d ₁	G	d ₅	d ₂	d ₃	l ₁	l ₂	l ₃	l ₄	l ₅	l ₆	d ₆	e
30	31,75	M12	13	45	50,00	47,80	16,4	19,0	15,0	5,5	24	M4	21
40	44,45	M16	17	50	63,55	68,40	22,8	25,0	18,5	8,2	32	M4	27
50	69,85	M24	25	80	97,50	101,75	35,5	37,7	30,0	11,5	47	M6	42

With internal coolant through the collar - form AD/B

Delivery with headless screws in closed position

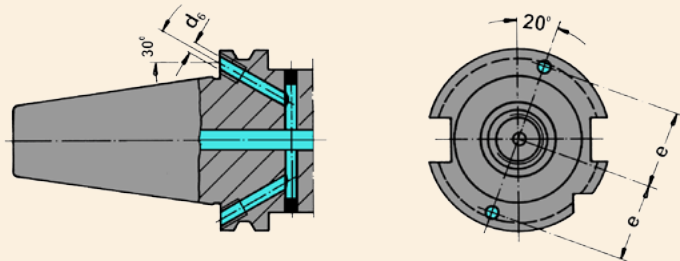

Material: Alloyed case-hardened steel, tensile core strength of min. 1200 N / mm². Case hardened HRC 60 ± 2 (HV 700 ± 50), hardening depth 0.8 mm ± 0.2 mm, black-finished and precisely grinded.

Form AD/B: Delivery in form AD, type B closed with releasable headless screws.

69871-CC-OZ



▣ 4

69871-CC-ER



▣ 5 - 7

69871-CCM-ER



▣ 8

69871-CC-HKS



▣ 9

69871-W



▣ 10 - 13

69871-W-C



▣ 14 - 15

69871-MT



▣ 16

69871-MTS



▣ 17

69871-RED-ISO



▣ 18

69871-FMH2



▣ 19 - 20

69871-FMH1



▣ 21 - 22

69871-FMH4



▣ 23

69871-DC



▣ 24

69871-QTCC



▣ 25

69871-QTCW



▣ 26

69871-HC



▣ 27 - 28

69871-SC



▣ 29 - 32

69871-SC-C



▣ 33

69871-IHA



▣ 34 - 35

69871-TA



▣ 35

69871-BLANKS



▣ 36

DIN 69871

ISO 60

MAS 403 BT

DIN 2080

HSK-A

VDI

MORSE



69871-CC-OZ

COLLET CHUCKS - OZ



Application:
For mounting straight-shank tools in collets.

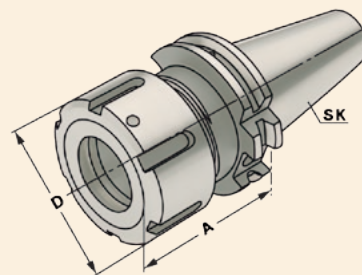

DIN 69871



$\nabla \leq 0,003$

G6,3
15.000 min⁻¹

Order no.	Taper	Range		
69871.30AD-CC.OZ16.060	SK 30	2 – 16 (OZ 16)	60	43
69871.30AD-CC.OZ25.080	SK 30	2 – 25 (OZ 25)	80	60
69871.40ADB-CC.OZ16.070	SK 40	2 – 16 (OZ 16)	70	43
69871.40ADB-CC.OZ25.070	SK 40	2 – 25 (OZ 25)	70	60
69871.40ADB-CC.OZ32.090	SK 40	3 – 32 (OZ 32)	90	72
69871.40ADB-CC.OZ16.100	SK 40	2 – 16 (OZ 16)	100	43
69871.40ADB-CC.OZ25.100	SK 40	2 – 25 (OZ 25)	100	60
69871.50ADB-CC.OZ25.070	SK 50	2 – 25 (OZ 25)	70	60
69871.50ADB-CC.OZ32.080	SK 50	3 – 32 (OZ 32)	80	72
69871.50ADB-CC.OZ32.100	SK 50	3 – 32 (OZ 32)	100	72

Delivery: With ball bearing clamping nut



DIN 69871

ISO 60

MAS 403 BT

DIN 2080

HSK-A

VDI

MORSE



69871-CC-ER

COLLET CHUCKS - ER



Application:
For mounting straight-shank tools in collets.

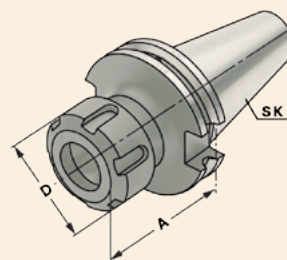

DIN 69871



$\nabla \leq 0,003$

G6,3
15.000 min⁻¹

Order no.	Taper	Range		
69871.30AD-CC.ER16.070	SK 30	1 – 10 (ER 16)	70	32
69871.30AD-CC.ER25.070	SK 30	2 – 16 (ER 25)	70	42
69871.30AD-CC.ER32.070	SK 30	2 – 20 (ER 32)	70	50
69871.30AD-CC.ER40.070	SK 30	3 – 26 (ER 40)	70	63
69871.30AD-CC.ER16.100	SK 30	1 – 10 (ER 16)	100	32
69871.30AD-CC.ER25.100	SK 30	2 – 16 (ER 25)	100	42
69871.30AD-CC.ER32.100	SK 30	2 – 20 (ER 32)	100	50
69871.40AD-CC.ER16.063	SK 40	1 – 10 (ER 16)	63	32
69871.40AD-CC.ER25.060	SK 40	2 – 16 (ER 25)	60	42
69871.40AD-CC.ER32.070	SK 40	2 – 20 (ER 32)	70	50
69871.40AD-CC.ER40.080	SK 40	3 – 26 (ER 40)	80	63
69871.40AD-CC.ER16.100	SK 40	1 – 10 (ER 16)	100	32
69871.40AD-CC.ER25.100	SK 40	2 – 16 (ER 25)	100	42
69871.40AD-CC.ER32.100	SK 40	2 – 20 (ER 32)	100	50
69871.40AD-CC.ER40.100	SK 40	3 – 26 (ER 40)	100	63

Delivery: With balanced clamping nut



DIN 69871

ISO 60

MAS 403 BT

DIN 2080

HSK-A

VDI

MORSE

69871-CC-ER

COLLET CHUCKS - ER



Application:
For mounting straight-shank tools in collets.

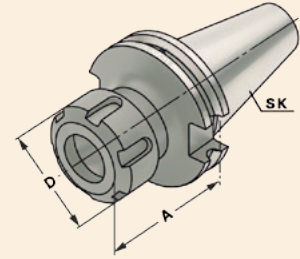

DIN 69871



$\nabla \leq 0,003$

G6,3
15.000 min⁻¹

Order no.	Taper	Range	A	D
69871.40ADB-CC.ER16.063	SK 40	1 – 10 (ER 16)	63	32
69871.40ADB-CC.ER25.060	SK 40	2 – 16 (ER 25)	60	42
69871.40ADB-CC.ER32.070	SK 40	2 – 20 (ER 32)	70	50
69871.40ADB-CC.ER40.080	SK 40	3 – 26 (ER 40)	80	63
69871.40ADB-CC.ER16.100	SK 40	1 – 10 (ER 16)	100	32
69871.40ADB-CC.ER25.100	SK 40	2 – 16 (ER 25)	100	42
69871.40ADB-CC.ER32.100	SK 40	2 – 20 (ER 32)	100	50
69871.40ADB-CC.ER40.100	SK 40	3 – 26 (ER 40)	100	63
69871.40ADB-CC.ER16.160	SK 40	1 – 10 (ER 16)	160	32
69871.40ADB-CC.ER25.160	SK 40	2 – 16 (ER 25)	160	42
69871.40ADB-CC.ER32.160	SK 40	2 – 20 (ER 32)	160	50
69871.40ADB-CC.ER40.160	SK 40	3 – 26 (ER 40)	160	63
69871.40ADB-CC.ER16.200	SK 40	1 – 10 (ER 16)	200	32
69871.40ADB-CC.ER25.200	SK 40	2 – 16 (ER 25)	200	42
69871.40ADB-CC.ER32.200	SK 40	2 – 20 (ER 32)	200	50
69871.40ADB-CC.ER40.200	SK 40	3 – 26 (ER 40)	200	63

Delivery: **With balanced clamping nut**



69871-CC-ER

COLLET CHUCKS - ER



Application:
For mounting straight-shank tools in collets.

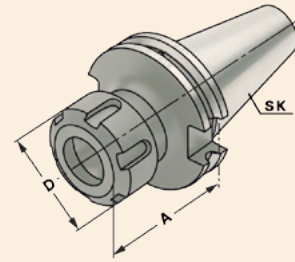

DIN 69871



$\nabla \leq 0,003$

G6,3
15.000 min⁻¹

Order no.	Taper	Range	A	D
69871.50ADB-CC.ER16.070	SK 50	1 – 10 (ER 16)	70	32
69871.50ADB-CC.ER25.060	SK 50	2 – 16 (ER 25)	60	42
69871.50ADB-CC.ER32.070	SK 50	2 – 20 (ER 32)	70	50
69871.50ADB-CC.ER40.080	SK 50	3 – 26 (ER 40)	80	63
69871.50ADB-CC.ER16.100	SK 50	1 – 10 (ER 16)	100	32
69871.50ADB-CC.ER25.100	SK 50	2 – 16 (ER 25)	100	42
69871.50ADB-CC.ER32.100	SK 50	2 – 20 (ER 32)	100	50
69871.50ADB-CC.ER40.100	SK 50	3 – 26 (ER 40)	100	63
69871.50ADB-CC.ER16.160	SK 50	1 – 10 (ER 16)	160	32
69871.50ADB-CC.ER25.160	SK 50	2 – 16 (ER 25)	160	42
69871.50ADB-CC.ER32.160	SK 50	2 – 20 (ER 32)	160	50
69871.50ADB-CC.ER40.160	SK 50	3 – 26 (ER 40)	160	63
69871.50ADB-CC.ER16.200	SK 50	1 – 10 (ER 16)	200	32
69871.50ADB-CC.ER25.200	SK 50	2 – 16 (ER 25)	200	42
69871.50ADB-CC.ER32.200	SK 50	2 – 20 (ER 32)	200	50
69871.50ADB-CC.ER40.200	SK 50	3 – 26 (ER 40)	200	63

Delivery: With balanced clamping nut



DIN 69871

ISO 60

MAS 403 BT

DIN 2080

HSK-A

VDI

MORSE



69871-CCM-ER

MINI COLLET CHUCKS - ER



Application:
For mounting straight-shank tools in collets with.

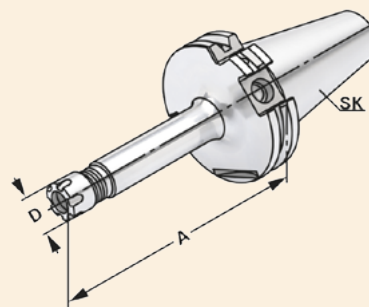

DIN 69871



$\nearrow \leq 0,003$

G6,3
15.000 min⁻¹

Order no.	Taper	Range	A	D
69871.40ADB-CCM.ER11.055	SK 40	1 – 7 (ER 11)	55	16
69871.40ADB-CCM.ER11.100	SK 40	1 – 7 (ER 11)	100	16
69871.40ADB-CCM.ER11.160	SK 40	1 – 7 (ER 11)	160	16
69871.40ADB-CCM.ER16.055	SK 40	1 – 10 (ER 16)	55	22
69871.40ADB-CCM.ER16.100	SK 40	1 – 10 (ER 16)	100	22
69871.40ADB-CCM.ER16.160	SK 40	1 – 10 (ER 16)	160	22



DIN 69871

ISO 60

MAS 403 BT

DIN 2080

HSK-A

VDI

MORSE



69871-CC-HKS

HIGH PERFORMANCE CHUCKS - HKS



Application:

For mounting straight-shank tools acc. DIN 1835 form A+B+E and DIN 6535 form HA+HB+HE (smaller than dia. 20 mm or 32 mm only with reduction sleeve).

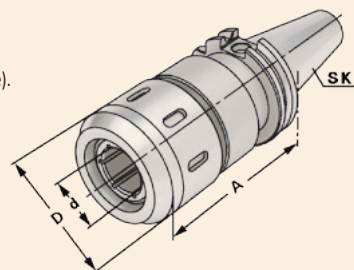

DIN 69871



$\nabla \leq 0,003$

G6,3
15.000 min⁻¹

Order no.	Taper	Range	A	D
69871.40ADB-CC.HKS20.090	SK 40	3-20 (HKS 20)	90	53
69871.40ADB-CC.HKS32.105	SK 40	3-32 (HKS 32)	105	68
69871.50ADB-CC.HKS20.090	SK 50	3-20 (HKS 20)	90	53
69871.50ADB-CC.HKS32.090	SK 50	3-32 (HKS 32)	90	68



DIN 69871

ISO 60

MAS 403 BT

DIN 2080

HSK-A

VDI

MORSE



69871-W

WELDON END MILL HOLDERS



Application:
For mounting straight-shank tools with flat according to DIN 1835 form B (Weldon).

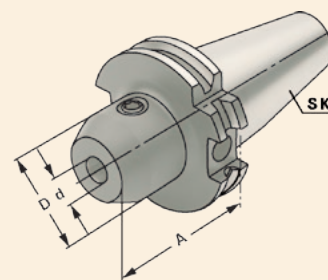

DIN 69871



Form AD

$\nabla \leq 0,003$

G6,3
15.000 min⁻¹

Order no.	Taper	dH4	A	D
69871.30AD-W.06.050	SK 30	6	50	25
69871.30AD-W.08.050	SK 30	8	50	28
69871.30AD-W.10.050	SK 30	10	50	35
69871.30AD-W.12.050	SK 30	12	50	42
69871.30AD-W.14.063	SK 30	14	63	44
69871.30AD-W.16.063	SK 30	16	63	48
69871.30AD-W.18.063	SK 30	18	63	50
69871.30AD-W.20.070	SK 30	20	70	52
69871.40AD-W.06.050	SK 40	6	50	25
69871.40AD-W.08.050	SK 40	8	50	28
69871.40AD-W.10.050	SK 40	10	50	35
69871.40AD-W.12.050	SK 40	12	50	42
69871.40AD-W.14.050	SK 40	14	50	44
69871.40AD-W.16.063	SK 40	16	63	48
69871.40AD-W.18.063	SK 40	18	63	50
69871.40AD-W.20.063	SK 40	20	63	52
69871.40AD-W.25.100	SK 40	25	100	65
69871.40AD-W.32.100	SK 40	32	100	72
69871.40AD-W.06.100	SK 40	6	100	25
69871.40AD-W.08.100	SK 40	8	100	28
69871.40AD-W.10.100	SK 40	10	100	35
69871.40AD-W.12.100	SK 40	12	100	42
69871.40AD-W.14.100	SK 40	14	100	44
69871.40AD-W.16.100	SK 40	16	100	48
69871.40AD-W.18.100	SK 40	18	100	50
69871.40AD-W.20.100	SK 40	20	100	52

Note: From d = 25 on two clamping screws

Delivery: With clamping screw



69871-W

WELDON END MILL HOLDERS



Application:
For mounting straight-shank tools with flat according to DIN 1835 form B (Weldon).

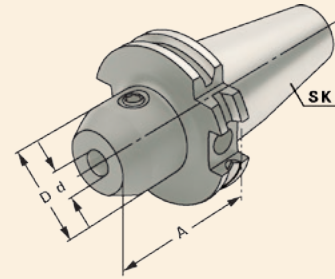

DIN 69871



$\nabla \leq 0,003$

G6,3
15.000 min⁻¹

Order no.	Taper	dH4	A	D
69871.40ADB-W.16.035	SK 40	16	35	45
69871.40ADB-W.20.035	SK 40	20	35	45
69871.40ADB-W.25.035	SK 40	25	35	50
69871.40ADB-W.32.065	SK 40	32	65	50
69871.40ADB-W.06.050	SK 40	6	50	25
69871.40ADB-W.08.050	SK 40	8	50	28
69871.40ADB-W.10.050	SK 40	10	50	35
69871.40ADB-W.12.050	SK 40	12	50	42
69871.40ADB-W.14.050	SK 40	14	50	44
69871.40ADB-W.16.063	SK 40	16	63	48
69871.40ADB-W.18.063	SK 40	18	63	50
69871.40ADB-W.20.063	SK 40	20	63	52
69871.40ADB-W.25.100	SK 40	25	100	65
69871.40ADB-W.32.100	SK 40	32	100	72
69871.40ADB-W.40.120	SK 40	40	120	80
69871.40ADB-W.06.100	SK 40	6	100	25
69871.40ADB-W.08.100	SK 40	8	100	28
69871.40ADB-W.10.100	SK 40	10	100	35
69871.40ADB-W.12.100	SK 40	12	100	42
69871.40ADB-W.14.100	SK 40	14	100	44
69871.40ADB-W.16.100	SK 40	16	100	48
69871.40ADB-W.18.100	SK 40	18	100	50
69871.40ADB-W.20.100	SK 40	20	100	52
69871.40ADB-W.06.160	SK 40	6	160	25
69871.40ADB-W.08.160	SK 40	8	160	28
69871.40ADB-W.10.160	SK 40	10	160	35
69871.40ADB-W.12.160	SK 40	12	160	42
69871.40ADB-W.14.160	SK 40	14	160	44
69871.40ADB-W.16.160	SK 40	16	160	48
69871.40ADB-W.18.160	SK 40	18	160	50
69871.40ADB-W.20.160	SK 40	20	160	52
69871.40ADB-W.25.160	SK 40	25	160	65
69871.40ADB-W.32.160	SK 40	32	160	72
69871.40ADB-W.40.160	SK 40	40	160	80

Note: From d = 25 on two clamping screws

Delivery: With clamping screw

DIN 69871

ISO 60

MAS 403 BT

DIN 2080

HSK-A

VDI

MORSE



69871-W

WELDON END MILL HOLDERS



Application:
For mounting straight-shank tools with flat according to DIN 1835 form B (Weldon).

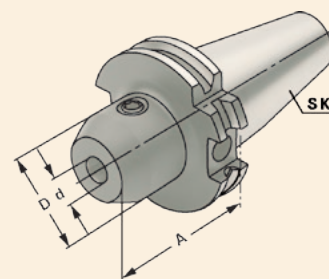

DIN 69871
Form AD/B
 $\nabla \leq 0,003$
G6,3 15.000 min⁻¹

Order no.	Taper	dH4	A	D
69871.50ADB-W.06.063	SK 50	6	63	25
69871.50ADB-W.08.063	SK 50	8	63	28
69871.50ADB-W.10.063	SK 50	10	63	35
69871.50ADB-W.12.063	SK 50	12	63	42
69871.50ADB-W.14.063	SK 50	14	63	44
69871.50ADB-W.16.063	SK 50	16	63	48
69871.50ADB-W.18.063	SK 50	18	63	50
69871.50ADB-W.20.063	SK 50	20	63	52
69871.50ADB-W.25.080	SK 50	25	80	65
69871.50ADB-W.32.100	SK 50	32	100	72
69871.50ADB-W.40.100	SK 50	40	100	80

Note: From d = 25 on two clamping screws

Delivery: With clamping screw



DIN 69871

ISO 60

MAS 403 BT

DIN 2080

HSK-A

VDI

MORSE



69871-W

WELDON END MILL HOLDERS



Application:
For mounting straight-shank tools with flat according to DIN 1835 form B (Weldon).

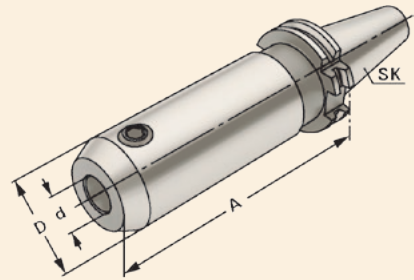

DIN 69871



$\nabla \leq 0,003$

G6,3
15.000 min⁻¹

Order no.	Taper	dH4	A	D
69871.50ADB-W.06.100	SK 50	6	100	25
69871.50ADB-W.08.100	SK 50	8	100	28
69871.50ADB-W.10.100	SK 50	10	100	35
69871.50ADB-W.12.100	SK 50	12	100	42
69871.50ADB-W.14.100	SK 50	14	100	44
69871.50ADB-W.16.100	SK 50	16	100	48
69871.50ADB-W.18.100	SK 50	18	100	50
69871.50ADB-W.20.100	SK 50	20	100	52
69871.50ADB-W.25.120	SK 50	25	120	65
69871.50ADB-W.06.160	SK 50	6	160	25
69871.50ADB-W.08.160	SK 50	8	160	28
69871.50ADB-W.10.160	SK 50	10	160	35
69871.50ADB-W.12.160	SK 50	12	160	42
69871.50ADB-W.14.160	SK 50	14	160	44
69871.50ADB-W.16.160	SK 50	16	160	48
69871.50ADB-W.18.160	SK 50	18	160	50
69871.50ADB-W.20.160	SK 50	20	160	52
69871.50ADB-W.25.160	SK 50	25	160	65
69871.50ADB-W.32.160	SK 50	32	160	72
69871.50ADB-W.40.160	SK 50	40	160	80
69871.50ADB-W.06.200	SK 50	6	200	25
69871.50ADB-W.08.200	SK 50	8	200	28
69871.50ADB-W.10.200	SK 50	10	200	35
69871.50ADB-W.12.200	SK 50	12	200	42
69871.50ADB-W.14.200	SK 50	14	200	44
69871.50ADB-W.16.200	SK 50	16	200	48
69871.50ADB-W.18.200	SK 50	18	200	50
69871.50ADB-W.20.200	SK 50	20	200	52
69871.50ADB-W.25.200	SK 50	25	200	65
69871.50ADB-W.32.200	SK 50	32	200	72
69871.50ADB-W.40.200	SK 50	40	200	80



Note:

From d = 25 on two clamping screws

Delivery:

With clamping screw

DIN 69871

ISO 60

MAS 403 BT

DIN 2080

HSK-A

VDI

MORSE



69871-W-C

WELDON END MILL HOLDERS WITH COOLANT CHANNELS



Application:
 For mounting straight-shank tools with flat according to DIN 1835 form B (Weldon).
 With coolant channels for optimal coolant at the cutting edge.

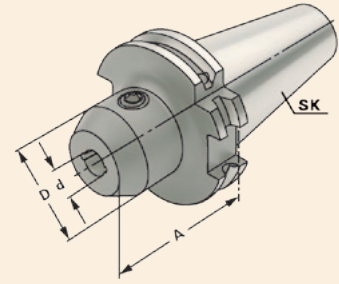

DIN 69871
Form AD/B
 $\nabla \leq 0,003$
G6,3 15.000 min⁻¹

Order no.	Taper	dH4	A	D
69871.40ADB-W.06.050.C	SK 40	6	50	25
69871.40ADB-W.08.050.C	SK 40	8	50	28
69871.40ADB-W.10.050.C	SK 40	10	50	35
69871.40ADB-W.12.050.C	SK 40	12	50	42
69871.40ADB-W.14.050.C	SK 40	14	50	44
69871.40ADB-W.16.063.C	SK 40	16	63	48
69871.40ADB-W.18.063.C	SK 40	18	63	50
69871.40ADB-W.20.063.C	SK 40	20	63	52
69871.40ADB-W.25.100.C	SK 40	25	100	65
69871.40ADB-W.32.100.C	SK 40	32	100	72
69871.40ADB-W.40.120.C	SK 40	40	120	80
69871.40ADB-W.06.100.C	SK 40	6	100	25
69871.40ADB-W.08.100.C	SK 40	8	100	28
69871.40ADB-W.10.100.C	SK 40	10	100	35
69871.40ADB-W.12.100.C	SK 40	12	100	42
69871.40ADB-W.14.100.C	SK 40	14	100	44
69871.40ADB-W.16.100.C	SK 40	16	100	48
69871.40ADB-W.18.100.C	SK 40	18	100	50
69871.40ADB-W.20.100.C	SK 40	20	100	52

Note:
 From d = 25 on two clamping screws
 d = 6 to 14 with two coolant channels
 d = 16 to 40 with four coolant channels
 For tools with through coolant an O-ring must be used.



Delivery: With clamping screw and O-ring

DIN 69871

ISO 60

MAS 403 BT

DIN 2080

HSK-A

VDI

MORSE



69871-W-C

WELDON END MILL HOLDERS WITH COOLANT CHANNELS



Application:
 For mounting straight-shank tools with flat according to DIN 1835 form B (Weldon).
 With coolant channels for optimal coolant at the cutting edge.

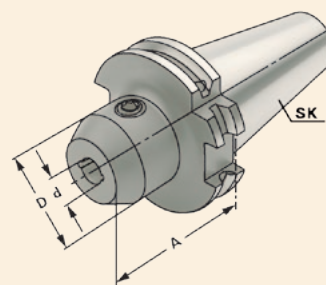

DIN 69871



$\nabla \leq 0,003$

G6,3
15.000 min⁻¹

Order no.	Taper	dH4	A	D
69871.50ADB-W.06.063.C	SK 50	6	63	25
69871.50ADB-W.08.063.C	SK 50	8	63	28
69871.50ADB-W.10.063.C	SK 50	10	63	35
69871.50ADB-W.12.063.C	SK 50	12	63	42
69871.50ADB-W.14.063.C	SK 50	14	63	44
69871.50ADB-W.16.063.C	SK 50	16	63	48
69871.50ADB-W.18.063.C	SK 50	18	63	50
69871.50ADB-W.20.063.C	SK 50	20	63	52
69871.50ADB-W.25.080.C	SK 50	25	80	65
69871.50ADB-W.32.100.C	SK 50	32	100	72
69871.50ADB-W.40.100.C	SK 50	40	100	80
69871.50ADB-W.06.100.C	SK 50	6	100	25
69871.50ADB-W.08.100.C	SK 50	8	100	28
69871.50ADB-W.10.100.C	SK 50	10	100	35
69871.50ADB-W.12.100.C	SK 50	12	100	42
69871.50ADB-W.14.100.C	SK 50	14	100	44
69871.50ADB-W.16.100.C	SK 50	16	100	48
69871.50ADB-W.18.100.C	SK 50	18	100	50
69871.50ADB-W.20.100.C	SK 50	20	100	52

Note: From d = 25 on two clamping screws
 d = 6 to 14 with two coolant channels
 d = 16 to 40 with four coolant channels
 For tools with through coolant an O-ring must be used.



Delivery: With clamping screw and O-ring

DIN 69871

ISO 60

MAS 403 BT

DIN 2080

HSK-A

VDI

MORSE



69871-MT

HOLDERS FOR MORSE TAPER



Application:

For mounting tools with Morse taper shank and tang according to DIN 228-1 form B.

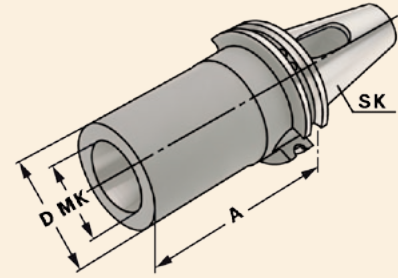

DIN 69871



Form AD

$\nearrow \leq 0,005$

G6,3
15.000 min⁻¹

Order no.	Taper	MK	A	D
69871.30AD-MT.1.050	SK 30	1	50	25
69871.30AD-MT.2.065	SK 30	2	65	32
69871.30AD-MT.3.080	SK 30	3	80	40
69871.40AD-MT.1.050	SK 40	1	50	25
69871.40AD-MT.2.050	SK 40	2	50	32
69871.40AD-MT.3.070	SK 40	3	70	40
69871.40AD-MT.4.095	SK 40	4	95	48
69871.40AD-MT.2.117	SK 40	2	117	32
69871.40AD-MT.3.133	SK 40	3	133	40
69871.40AD-MT.4.156	SK 40	4	156	48
69871.50ADB-MT.1.045	SK 50	1	45	25
69871.50ADB-MT.2.060	SK 50	2	60	32
69871.50ADB-MT.3.065	SK 50	3	65	40
69871.50ADB-MT.4.095	SK 50	4	95	48
69871.50ADB-MT.5.105	SK 50	5	105	63
69871.50AD-MT.2.117	SK 50	2	117	32
69871.50AD-MT.3.137	SK 50	3	137	40
69871.50AD-MT.4.167	SK 50	4	167	48
69871.50AD-MT.5.197	SK 50	5	197	63
69871.50AD-MT.6.250	SK 50	6	250	90



69871-MTS

HOLDERS FOR MORSE TAPER WITH DRAWBAR THREAD



Application:
For clamping tools with Morse taper shank and thread according to DIN 228-1 form A.

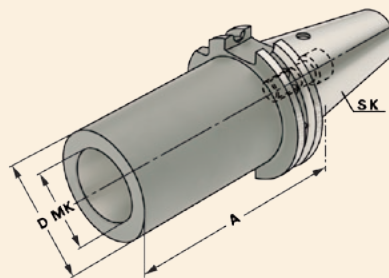

DIN 69871

Form A

$\nabla \leq 0,005$

G6,3
15.000 min⁻¹

Order no.	Taper	MK	M	A	D
69871.40A-MTS.1.050	SK 40	1	M6	50	25
69871.40A-MTS.2.050	SK 40	2	M10	50	32
69871.40A-MTS.3.070	SK 40	3	M12	70	40
69871.40A-MTS.4.095	SK 40	4	M16	95	48
69871.50A-MTS.1.045	SK 50	1	M6	45	25
69871.50A-MTS.2.060	SK 50	2	M10	60	32
69871.50A-MTS.3.065	SK 50	3	M12	65	40
69871.50A-MTS.4.070	SK 50	4	M16	70	48
69871.50A-MTS.5.100	SK 50	5	M20	100	63

Version: **DIN 69871 form A**

Delivery: **With built-in tightening bolt**



DIN 69871

ISO 60

MAS 403 BT

DIN 2080

HSK-A

VDI

MORSE



69871-RED-ISO

REDUCTIONS FOR ISO CONE



Application:
For mounting tapers according to DIN 69871,
JIS B 6339 and DIN 2080.

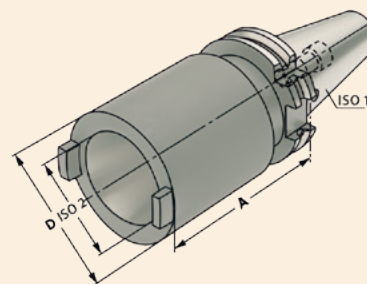

DIN 69871
Form A
 $\nabla \leq 0,005$
G6,3 15.000 min⁻¹

Order no.	ISO 1	ISO 2	A	D
69871.40A-RED.ISO.30.050	SK 40	ISO 30	50	50
69871.40A-RED.ISO.40.100	SK 40	ISO 40	100	63
69871.50A-RED.ISO.40.070	SK 50	ISO 40	70	70
69871.50A-RED.ISO.50.120	SK 50	ISO 50	120	97

Note: Delivered with a built-in screw for shortened taper tools. Additional screw for DIN 2080 tools included.



DIN 69871

ISO 60

MAS 403 BT

DIN 2080

HSK-A

VDI

MORSE



69871-FMH2

COMBI SHELL MILL HOLDERS



Application:

For mounting milling cutters with transverse or longitudinal groove.

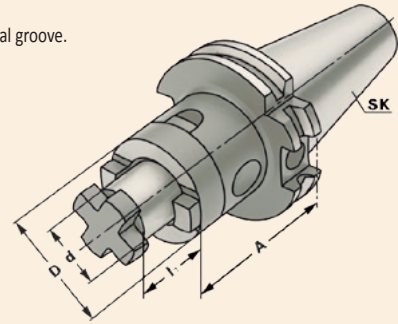

DIN 69871



$\nabla \leq 0,005$

G6,3
15.000 min⁻¹

Order no.	Taper	dh6	A	l ₁	D
69871.30AD-FMH2.16.050	SK 30	16	50	17	32
69871.30AD-FMH2.22.050	SK 30	22	50	19	40
69871.30AD-FMH2.27.055	SK 30	27	55	21	48
69871.30AD-FMH2.32.060	SK 30	32	60	24	58
69871.40ADB-FMH2.16.055	SK 40	16	55	17	32
69871.40ADB-FMH2.22.055	SK 40	22	55	19	40
69871.40ADB-FMH2.27.055	SK 40	27	55	21	48
69871.40ADB-FMH2.32.060	SK 40	32	60	24	58
69871.40ADB-FMH2.40.060	SK 40	40	60	27	70
69871.40ADB-FMH2.16.100	SK 40	16	100	17	32
69871.40ADB-FMH2.22.100	SK 40	22	100	19	40
69871.40ADB-FMH2.27.100	SK 40	27	100	21	48
69871.40ADB-FMH2.32.100	SK 40	32	100	24	58
69871.40ADB-FMH2.40.100	SK 40	40	100	27	70
69871.40ADB-FMH2.16.160	SK 40	16	160	17	32
69871.40ADB-FMH2.22.160	SK 40	22	160	19	40
69871.40ADB-FMH2.27.160	SK 40	27	160	21	48
69871.40ADB-FMH2.32.160	SK 40	32	160	24	58
69871.40ADB-FMH2.40.160	SK 40	40	160	27	70

Delivery: With retaining screw, driving ring and feather key



DIN 69871

ISO 60

MAS 403 BT

DIN 2080

HSK-A

VDI

MORSE



69871-FMH2

COMBI SHELL MILL HOLDERS



Application:

For mounting milling cutters with transverse or longitudinal groove.

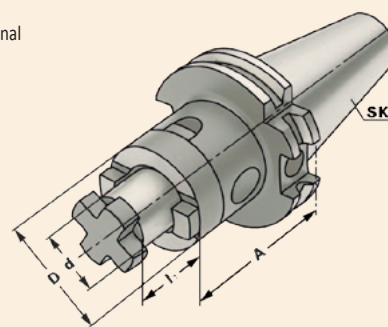

DIN 69871



$\nabla \leq 0,005$

G6,3
15.000 min⁻¹

Order no.	Taper	dh6	A	l ₁	D
69871.50ADB-FMH2.16.055	SK 50	16	55	17	32
69871.50ADB-FMH2.22.055	SK 50	22	55	19	40
69871.50ADB-FMH2.27.055	SK 50	27	55	21	48
69871.50ADB-FMH2.32.055	SK 50	32	55	24	58
69871.50ADB-FMH2.40.055	SK 50	40	55	27	70
69871.50ADB-FMH2.16.100	SK 50	16	100	17	32
69871.50ADB-FMH2.22.100	SK 50	22	100	19	40
69871.50ADB-FMH2.27.100	SK 50	27	100	21	48
69871.50ADB-FMH2.32.100	SK 50	32	100	24	58
69871.50ADB-FMH2.40.100	SK 50	40	100	27	70
69871.50ADB-FMH2.16.160	SK 50	16	160	17	32
69871.50ADB-FMH2.22.160	SK 50	22	160	19	40
69871.50ADB-FMH2.27.160	SK 50	27	160	21	48
69871.50ADB-FMH2.32.160	SK 50	32	160	24	58
69871.50ADB-FMH2.40.160	SK 50	40	160	27	70

Delivery: With retaining screw, driving ring and feather key



242



243 -244



246



190



245



69871-FMH1

SHELL MILL HOLDERS



Application:
For mounting milling cutters with transversal groove.

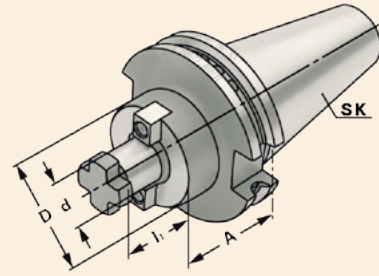

DIN 69871



$\nabla \leq 0,005$

G6,3
15.000 min⁻¹

Order no.	Taper	dh6	A	l ₁	D
69871.30AD-FMH1.16.040	SK 30	16	40	17	38
69871.30AD-FMH1.22.040	SK 30	22	40	19	48
69871.30AD-FMH1.27.050	SK 30	27	50	21	58
69871.30AD-FMH1.32.050	SK 30	32	50	24	78
69871.40ADB-FMH1.16.035	SK 40	16	35	17	38
69871.40ADB-FMH1.22.035	SK 40	22	35	19	48
69871.40ADB-FMH1.27.040	SK 40	27	40	21	58
69871.40ADB-FMH1.32.050	SK 40	32	50	24	78
69871.40ADB-FMH1.40.050	SK 40	40	50	27	88
69871.40ADB-FMH1.16.100	SK 40	16	100	17	38
69871.40ADB-FMH1.22.100	SK 40	22	100	19	48
69871.40ADB-FMH1.27.100	SK 40	27	100	21	58
69871.40ADB-FMH1.32.100	SK 40	32	100	24	78
69871.40ADB-FMH1.40.100	SK 40	40	100	27	88
69871.40ADB-FMH1.16.160	SK 40	16	160	17	38
69871.40ADB-FMH1.22.160	SK 40	22	160	19	48
69871.40ADB-FMH1.27.160	SK 40	27	160	21	58
69871.40ADB-FMH1.32.160	SK 40	32	160	24	78
69871.40ADB-FMH1.40.160	SK 40	40	160	27	88

d = 40:

For large diameter face mill cutters with four additional threaded holes according to DIN 2079.

Delivery:

With drivers, cross head retaining screw and cylinder head retaining screw for cutters with central coolant.



DIN 69871

ISO 60

MAS 403 BT

DIN 2080

HSK-A

VDI

MORSE



69871-FMH1

SHELL MILL HOLDERS



Application:
For mounting milling cutters with transversal groove.

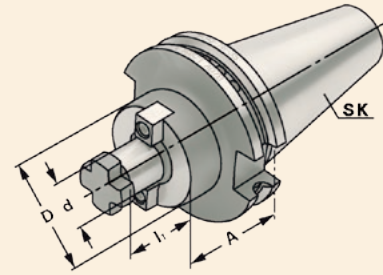

DIN 69871



$\nabla \leq 0,005$

G6,3
15.000 min⁻¹

Order no.	Taper	dh6	A	l ₁	D
69871.50ADB-FMH1.16.045	SK 50	16	45	17	38
69871.50ADB-FMH1.22.035	SK 50	22	35	19	48
69871.50ADB-FMH1.27.040	SK 50	27	40	21	58
69871.50ADB-FMH1.32.050	SK 50	32	50	24	78
69871.50ADB-FMH1.40.050	SK 50	40	50	27	88
69871.50ADB-FMH1.60.070	SK 50	60	70	40	129
69871.50ADB-FMH1.16.100	SK 50	16	100	17	38
69871.50ADB-FMH1.22.100	SK 50	22	100	19	48
69871.50ADB-FMH1.27.100	SK 50	27	100	21	58
69871.50ADB-FMH1.32.100	SK 50	32	100	24	78
69871.50ADB-FMH1.40.100	SK 50	40	100	27	88
69871.50ADB-FMH1.16.160	SK 50	16	160	17	38
69871.50ADB-FMH1.22.160	SK 50	22	160	19	48
69871.50ADB-FMH1.27.160	SK 50	27	160	21	58
69871.50ADB-FMH1.32.160	SK 50	32	160	24	78
69871.50ADB-FMH1.40.160	SK 50	40	160	27	88
69871.50ADB-FMH1.16.200	SK 50	16	200	17	38
69871.50ADB-FMH1.22.200	SK 50	22	200	19	48
69871.50ADB-FMH1.27.200	SK 50	27	200	21	58
69871.50ADB-FMH1.32.200	SK 50	32	200	24	78
69871.50ADB-FMH1.40.200	SK 50	40	200	27	88

d = 40/d = 60: For large diameter face mill cutters with four additional threaded holes according to DIN 2079.

Delivery: With drivers, cross head retaining screw and cylinder head retaining screw for cutters with central coolant.
For d = 60 only with four fixation screws according to DIN 912.



242

243 - 244

190

69871-FMH4

HOLDERS FOR DISC MILLING CUTTERS



Application:
For mounting disc milling cutters.

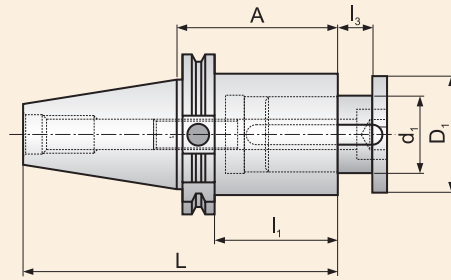

DIN 69871

Form A

$\nabla \leq 0,005$

G6,3
15.000 min⁻¹

Order no.	Taper	d ₁	A	D ₁	L	l ₁	l ₃
69871.40A-FMH4.27.065	SK 40	27	65	42	133,4	45,9	0-15
69871.40A-FMH4.32.090	SK 40	32	90	48	158,4	70,9	0-24
69871.50A-FMH4.40.100	SK 50	40	100	58	201,7	80,9	0-30
69871.50A-FMH4.50.160	SK 50	50	160	72	261,7	140,9	0-32
69871.50A-FMH4.60.180	SK 50	60	180	90	281,7	160,9	0-40

Delivery: With drive shafts, screws and hexagonal key.



DIN 69871

ISO 60

MAS 403 BT

DIN 2080

HSK-A

VDI

MORSE



69871-DC

DRILL CHUCK HOLDERS



Application:
For mounting tools with straight shanks.

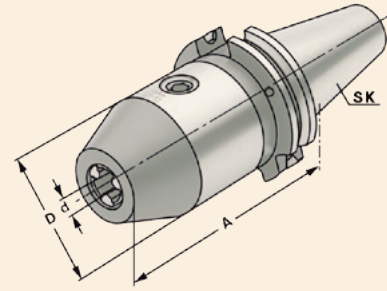

DIN 69871



$\nabla \leq 0,030$

G6,3
15.000 min⁻¹

Order no.	Taper	Range	A	D
69871.30AD-DC.08.070	SK 30	0,5 – 8	70	36
69871.30AD-DC.13.111	SK 30	1 – 13	111	50
69871.30AD-DC.16.116	SK 30	2,5 – 16	116	50
69871.40AD-DC.08.070	SK 40	0,5 – 8	70	36
69871.40AD-DC.13.090	SK 40	1 – 13	90	50
69871.40AD-DC.16.095	SK 40	2,5 – 16	95	50
69871.50AD-DC.13.090	SK 50	1 – 13	90	50
69871.50AD-DC.16.095	SK 50	2,5 – 16	95	50

Note: High precision and accurate concentricity of ≤ 0.03 mm. Secure gripping of the tool through mechanical amplification of the clamping force. No automatic slackening of the clamping force while machining with either clockwise or counter clockwise rotation or on spindle stop. Clamping and releasing effected by means of an Allen wrench.

Delivery: With wrench



190

DIN 69871

ISO 60

MAS 403 BT

DIN 2080

HSK-A

VDI

MORSE



69871-QTCC

QUICK-CHANGE TAPPING CHUCKS WITH COMPENSATION



Application:
For the chucking of quick change adaptors for taps.

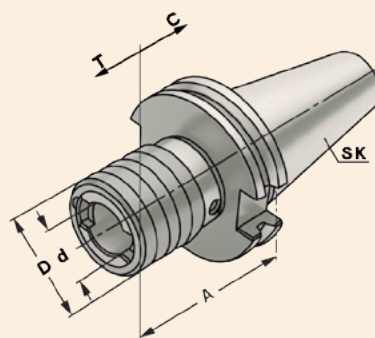

DIN 69871

Form A

G6,3
15.000 min⁻¹

Order no.	Taper	Range	Size	A	D	d	T	C
69871.30A-QTCC.M3.M14	SK 30	M3 – M14	1	65	38	19	7	7
69871.30A-QTCC.M5.M22	SK 30	M5 – M22	2	99	54	31	12	12
69871.40A-QTCC.M3.M14	SK 40	M3 – M14	1	59	38	19	7	7
69871.40A-QTCC.M5.M22	SK 40	M5 – M22	2	97	54	31	12	12
69871.40A-QTCC.M14.M36	SK 40	M14 – M36	3	156	78	48	17,5	17,5
69871.50A-QTCC.M3.M14	SK 50	M3 – M14	1	63	38	19	7	7
69871.50A-QTCC.M5.M22	SK 50	M5 – M22	2	97	54	31	12	12
69871.50A-QTCC.M14.M36	SK 50	M14 – M36	3	140	78	48	17,5	17,5

Note: For machining centres without synchronous spindle.



DIN 69871

ISO 60

MAS 403 BT

DIN 2080

HSK-A

VDI

MORSE



69871-QTCW

QUICK-CHANGE TAPPING CHUCKS WITHOUT COMPENSATION



Application:

For the chucking of quick change adaptors for taps.

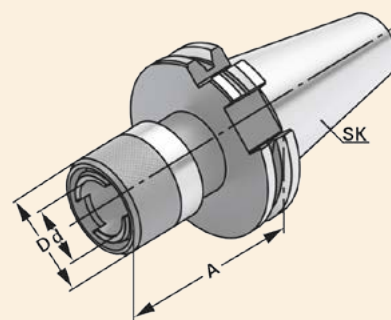

DIN 69871



Form AD

G6,3
15.000 min⁻¹

Order no.	Taper	Range	Size	A	D	d
69871.30AD-QTCW.M3.M14	SK 30	M3 – M14	1	58	38	19
69871.30AD-QTCW.M5.M22	SK 30	M5 – M22	2	103	54	31
69871.40AD-QTCW.M3.M14	SK 40	M3 – M14	1	62	38	19
69871.40AD-QTCW.M5.M22	SK 40	M5 – M22	2	95	54	31
69871.40AD-QTCW.M14.M36	SK 40	M14 – M36	3	130	78	48
69871.50AD-QTCW.M3.M14	SK 50	M3 – M14	1	60	38	19
69871.50AD-QTCW.M5.M22	SK 50	M5 – M22	2	85	54	31
69871.50AD-QTCW.M14.M36	SK 50	M14 – M36	3	117	78	48

Note: For machining centres with synchronous spindle.



222 - 224



225 - 227



228



190

DIN 69871

ISO 60

MAS 403 BT

DIN 2080

HSK-A

VDI

MORSE



69871-HC

HYDRAULIC CHUCKS



Application:

For mounting straight-shank tools acc. DIN 1835 form A+B+E and DIN 6535 form HA+HB+HE (for dia. 20 mm or 32 mm reduction sleeve can be used).

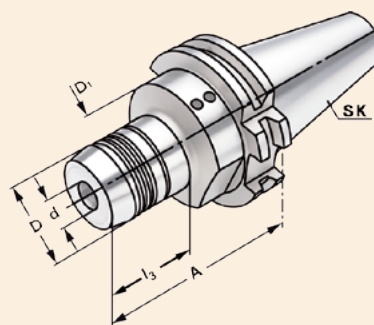

DIN 69871



$\nabla \leq 0,003$

G6,3
15.000 min⁻¹

Order no.	Taper	d	A	D	D ₁	l ₃
69871.30AD-HC.06.060	SK 30	6	60	26	45	25
69871.30AD-HC.08.064	SK 30	8	64	28	45	29
69871.30AD-HC.10.064	SK 30	10	64	30	45	35
69871.30AD-HC.12.072	SK 30	12	72	32	45	43
69871.30AD-HC.14.072	SK 30	14	72	34	45	42
69871.30AD-HC.16.072	SK 30	16	72	38	45	43
69871.30AD-HC.18.072	SK 30	18	72	40	45	43
69871.30AD-HC.20.090	SK 30	20	90	42	42	71
69871.40ADB-HC.06.068	SK 40	6	68	26	50	33
69871.40ADB-HC.08.068	SK 40	8	68	28	50	33
69871.40ADB-HC.10.072	SK 40	10	72	30	50	37
69871.40ADB-HC.12.077	SK 40	12	77	32	50	42
69871.40ADB-HC.14.077	SK 40	14	77	34	50	42
69871.40ADB-HC.16.080	SK 40	16	80	38	50	43
69871.40ADB-HC.18.080	SK 40	18	80	40	50	43
69871.40ADB-HC.20.082	SK 40	20	82	42	50	47
69871.40ADB-HC.25.117	SK 40	25	117	50	63	51
69871.40ADB-HC.32.117	SK 40	32	117	60	63	56
69871.40ADB-HC.06.110	SK 40	6	110	26	50	33
69871.40ADB-HC.08.110	SK 40	8	110	28	50	33
69871.40ADB-HC.10.110	SK 40	10	110	30	50	37
69871.40ADB-HC.12.110	SK 40	12	110	32	50	42
69871.40ADB-HC.14.110	SK 40	14	110	34	50	42
69871.40ADB-HC.16.110	SK 40	16	110	38	50	42
69871.40ADB-HC.18.110	SK 40	18	110	40	50	47
69871.40ADB-HC.20.110	SK 40	20	110	42	50	47

Delivery: With wrench



DIN 69871

ISO 60

MAS 403 BT

DIN 2080

HSK-A

VDI

MORSE



69871-HC

HYDRAULIC CHUCKS



Application:

For mounting straight-shank tools acc. DIN 1835 form A+B+E and DIN 6535 form HA+HB+HE (for dia. 20 mm or 32 mm reduction sleeve can be used).

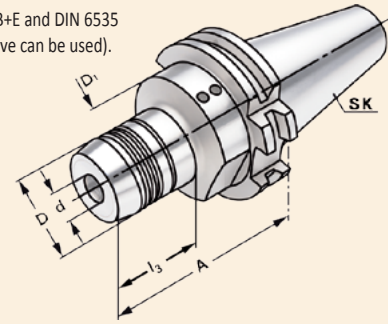

DIN 69871



$\nabla \leq 0,003$

G6,3
15.000 min⁻¹

Order no.	Taper	d	A	D	D ₁	l ₃
69871.50ADB-HC.06.068	SK 50	6	68	26	80	33
69871.50ADB-HC.08.068	SK 50	8	68	28	80	33
69871.50ADB-HC.10.072	SK 50	10	72	30	80	37
69871.50ADB-HC.12.077	SK 50	12	77	32	80	42
69871.50ADB-HC.14.077	SK 50	14	77	34	80	42
69871.50ADB-HC.16.080	SK 50	16	80	38	80	45
69871.50ADB-HC.18.080	SK 50	18	80	40	80	45
69871.50ADB-HC.20.082	SK 50	20	82	42	80	47
69871.50ADB-HC.25.087	SK 50	25	87	50	80	52
69871.50ADB-HC.32.091	SK 50	32	91	60	80	56
69871.50ADB-HC.06.110	SK 50	6	110	26	50	33
69871.50ADB-HC.08.110	SK 50	8	110	28	50	33
69871.50ADB-HC.10.110	SK 50	10	110	30	50	37
69871.50ADB-HC.12.110	SK 50	12	110	32	50	42
69871.50ADB-HC.14.110	SK 50	14	110	34	50	42
69871.50ADB-HC.16.110	SK 50	16	110	38	50	42
69871.50ADB-HC.18.110	SK 50	18	110	40	50	47
69871.50ADB-HC.20.110	SK 50	20	110	42	50	47
69871.50ADB-HC.25.110	SK 50	25	110	50	80	47
69871.50ADB-HC.32.110	SK 50	32	110	60	80	75
69871.50ADB-HC.06.150	SK 50	6	150	26	50	115
69871.50ADB-HC.08.150	SK 50	8	150	28	50	115
69871.50ADB-HC.10.150	SK 50	10	150	30	50	115
69871.50ADB-HC.12.150	SK 50	12	150	32	50	115
69871.50ADB-HC.14.150	SK 50	14	150	34	50	115
69871.50ADB-HC.16.150	SK 50	16	150	38	50	115
69871.50ADB-HC.18.150	SK 50	18	150	40	50	115
69871.50ADB-HC.20.150	SK 50	20	150	42	50	115
69871.50ADB-HC.25.150	SK 50	25	150	50	50	131
69871.50ADB-HC.32.150	SK 50	32	150	60	60	131
69871.50ADB-HC.40.150	SK 50	40	150	70	70	131



Delivery:

With wrench



69871-SC

SHRINK FIT HOLDERS



Application:
For mounting straight-shank tools.

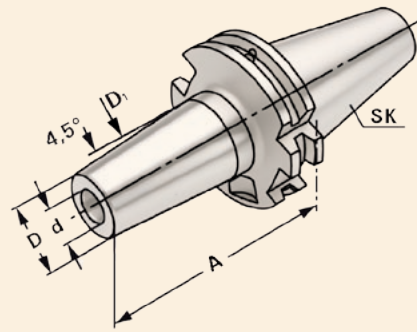

DIN 69871



$\nabla \leq 0,003$

G6,3
15.000 min⁻¹

Order no.	Taper	d	A	D	D ₁
69871.30AD-SC.03.080	SK 30	3	80	11	15
69871.30AD-SC.04.080	SK 30	4	80	14	22
69871.30AD-SC.05.080	SK 30	5	80	16	22
69871.30AD-SC.06.080	SK 30	6	80	21	27
69871.30AD-SC.08.080	SK 30	8	80	21	27
69871.30AD-SC.10.080	SK 30	10	80	24	32
69871.30AD-SC.12.100	SK 30	12	100	24	32
69871.30AD-SC.14.100	SK 30	14	100	27	34
69871.30AD-SC.16.100	SK 30	16	100	27	34
69871.30AD-SC.18.100	SK 30	18	100	33	42
69871.30AD-SC.20.100	SK 30	20	100	33	42
69871.30AD-SC.03.160	SK 30	3	160	11	15
69871.30AD-SC.04.160	SK 30	4	160	14	22
69871.30AD-SC.05.160	SK 30	5	160	16	22
69871.30AD-SC.06.160	SK 30	6	160	21	27
69871.30AD-SC.08.160	SK 30	8	160	21	27
69871.30AD-SC.10.160	SK 30	10	160	24	32
69871.30AD-SC.12.160	SK 30	12	160	24	32
69871.30AD-SC.14.160	SK 30	14	160	27	34
69871.30AD-SC.16.160	SK 30	16	160	27	34
69871.30AD-SC.18.160	SK 30	18	160	33	42
69871.30AD-SC.20.160	SK 30	20	160	33	42

For Ø 3, 4 and 5 mm only solid carbide tool shanks must be used!

Note: Toolholders suitable for induction-, contact- and hot air shrink units.
Ø 3, 4, 5 with h4-tolerance and Ø 6 – Ø 32 with h6-tolerance



190

DIN 69871

ISO 60

MAS 403 BT

DIN 2080

HSK-A

VDI

MORSE



69871-SC

SHRINK FIT HOLDERS



Application:
For mounting straight-shank tools.

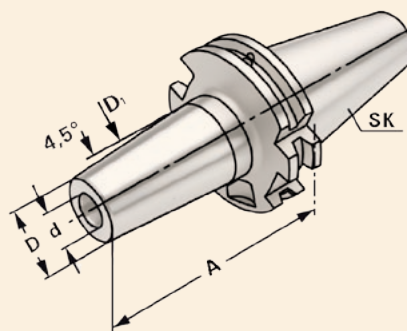

DIN 69871



$\nearrow \leq 0,003$

G6,3
15.000 min⁻¹

Order no.	Taper	d	A	D	D ₁
69871.40ADB-SC.03.080	SK 40	3	80	11	15
69871.40ADB-SC.04.080	SK 40	4	80	14	22
69871.40ADB-SC.05.080	SK 40	5	80	16	22
69871.40ADB-SC.06.080	SK 40	6	80	21	27
69871.40ADB-SC.08.080	SK 40	8	80	21	27
69871.40ADB-SC.10.080	SK 40	10	80	24	32
69871.40ADB-SC.12.080	SK 40	12	80	24	32
69871.40ADB-SC.14.080	SK 40	14	80	27	34
69871.40ADB-SC.16.080	SK 40	16	80	27	34
69871.40ADB-SC.18.080	SK 40	18	80	33	42
69871.40ADB-SC.20.080	SK 40	20	80	33	42
69871.40ADB-SC.25.100	SK 40	25	100	44	53
69871.40ADB-SC.32.100	SK 40	32	100	44	53
69871.40ADB-SC.03.120	SK 40	3	120	11	15
69871.40ADB-SC.04.120	SK 40	4	120	14	22
69871.40ADB-SC.05.120	SK 40	5	120	16	22
69871.40ADB-SC.06.120	SK 40	6	120	21	27
69871.40ADB-SC.08.120	SK 40	8	120	21	27
69871.40ADB-SC.10.120	SK 40	10	120	24	32
69871.40ADB-SC.12.120	SK 40	12	120	24	32
69871.40ADB-SC.14.120	SK 40	14	120	27	34
69871.40ADB-SC.16.120	SK 40	16	120	27	34
69871.40ADB-SC.18.120	SK 40	18	120	33	42
69871.40ADB-SC.20.120	SK 40	20	120	33	42
69871.40ADB-SC.25.120	SK 40	25	120	44	53
69871.40ADB-SC.32.120	SK 40	32	120	44	53

For \varnothing 3, 4 and 5 mm only solid carbide tool shanks must be used!

Note: Toolholders suitable for induction-, contact- and hot air shrink units.
 \varnothing 3, 4, 5 with h4-tolerance and \varnothing 6 – \varnothing 32 with h6-tolerance



190

DIN 69871

ISO 60

MAS 403 BT

DIN 2080

HSK-A

VDI

MORSE



69871-SC

SHRINK FIT HOLDERS



Application:
For mounting straight-shank tools.

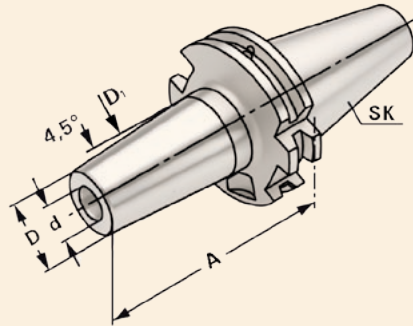

DIN 69871



$\nabla \leq 0,003$

G6,3
15.000 min⁻¹

Order no.	Taper	d	A	D	D ₁
69871.40ADB-SC.03.160	SK 40	3	160	11	15
69871.40ADB-SC.04.160	SK 40	4	160	14	22
69871.40ADB-SC.05.160	SK 40	5	160	16	22
69871.40ADB-SC.06.160	SK 40	6	160	21	27
69871.40ADB-SC.08.160	SK 40	8	160	21	27
69871.40ADB-SC.10.160	SK 40	10	160	24	32
69871.40ADB-SC.12.160	SK 40	12	160	24	32
69871.40ADB-SC.14.160	SK 40	14	160	27	34
69871.40ADB-SC.16.160	SK 40	16	160	27	34
69871.40ADB-SC.18.160	SK 40	18	160	33	42
69871.40ADB-SC.20.160	SK 40	20	160	33	42
69871.40ADB-SC.25.160	SK 40	25	160	44	53
69871.40ADB-SC.32.160	SK 40	32	160	44	53
69871.50ADB-SC.03.080	SK 50	3	80	11	15
69871.50ADB-SC.04.080	SK 50	4	80	14	22
69871.50ADB-SC.05.080	SK 50	5	80	16	22
69871.50ADB-SC.06.080	SK 50	6	80	21	27
69871.50ADB-SC.08.080	SK 50	8	80	21	27
69871.50ADB-SC.10.080	SK 50	10	80	24	32
69871.50ADB-SC.12.080	SK 50	12	80	24	32
69871.50ADB-SC.14.080	SK 50	14	80	27	34
69871.50ADB-SC.16.080	SK 50	16	80	27	34
69871.50ADB-SC.18.080	SK 50	18	80	33	42
69871.50ADB-SC.20.080	SK 50	20	80	33	42
69871.50ADB-SC.25.100	SK 50	25	100	44	53
69871.50ADB-SC.32.100	SK 50	32	100	44	53

For \varnothing 3, 4 and 5 mm only solid carbide tool shanks must be used!

Note:

Toolholders suitable for induction-, contact- and hot air shrink units.
 \varnothing 3, 4, 5 with h4-tolerance and \varnothing 6 – \varnothing 32 with h6-tolerance



190

DIN 69871

ISO 60

MAS 403 BT

DIN 2080

HSK-A

VDI

MORSE



69871-SC

SHRINK FIT HOLDERS



Application:
For mounting straight-shank tools.

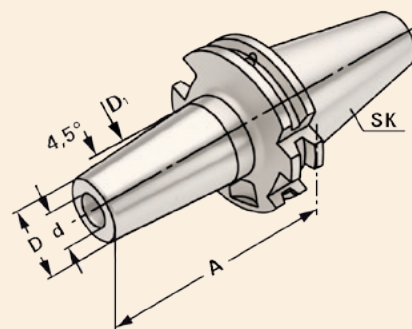

DIN 69871



$\nabla \leq 0,003$

G6,3
15.000 min⁻¹

Order no.	Taper	d	A	D	D ₁
69871.50ADB-SC.06.160	SK 50	6	160	21	27
69871.50ADB-SC.08.160	SK 50	8	160	21	27
69871.50ADB-SC.10.160	SK 50	10	160	24	32
69871.50ADB-SC.12.160	SK 50	12	160	24	32
69871.50ADB-SC.14.160	SK 50	14	160	27	34
69871.50ADB-SC.16.160	SK 50	16	160	27	34
69871.50ADB-SC.18.160	SK 50	18	160	33	42
69871.50ADB-SC.20.160	SK 50	20	160	33	42
69871.50ADB-SC.25.160	SK 50	25	160	44	53
69871.50ADB-SC.32.160	SK 50	32	160	44	53
69871.50ADB-SC.06.200	SK 50	6	200	21	27
69871.50ADB-SC.08.200	SK 50	8	200	21	27
69871.50ADB-SC.10.200	SK 50	10	200	24	32
69871.50ADB-SC.12.200	SK 50	12	200	24	32
69871.50ADB-SC.14.200	SK 50	14	200	27	34
69871.50ADB-SC.16.200	SK 50	16	200	27	34
69871.50ADB-SC.18.200	SK 50	18	200	33	42
69871.50ADB-SC.20.200	SK 50	20	200	33	42
69871.50ADB-SC.25.200	SK 50	25	200	44	53
69871.50ADB-SC.32.200	SK 50	32	200	44	53

Note: Toolholders suitable for induction-, contact- and hot air shrink units.
Ø 6 – Ø 32 with h6-tolerance



190

DIN 69871

ISO 60

MAS 403 BT

DIN 2080

HSK-A

VDI

MORSE



69871-SC-C

SHRINK FIT HOLDERS WITH COOLANT CHANNELS



Application:
For mounting straight-shank tools.

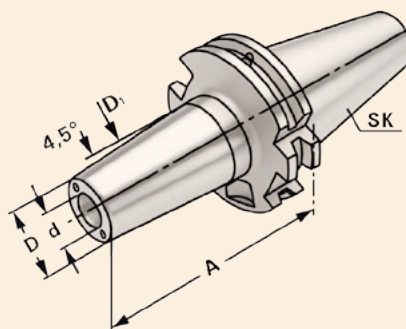

DIN 69871



$\nabla \leq 0,003$

G6,3
15.000 min⁻¹

Order no.	Taper	d	A	D	D ₁
69871.40ADB-SC.06.080.C	SK 40	6	80	21	27
69871.40ADB-SC.08.080.C	SK 40	8	80	21	27
69871.40ADB-SC.10.080.C	SK 40	10	80	24	32
69871.40ADB-SC.12.080.C	SK 40	12	80	24	32
69871.40ADB-SC.14.080.C	SK 40	14	80	27	34
69871.40ADB-SC.16.080.C	SK 40	16	80	27	34
69871.40ADB-SC.18.080.C	SK 40	18	80	33	42
69871.40ADB-SC.20.080.C	SK 40	20	80	33	42
69871.40ADB-SC.25.100.C	SK 40	25	100	44	53
69871.40ADB-SC.32.100.C	SK 40	32	100	44	53
69871.50ADB-SC.06.080.C	SK 50	6	80	21	27
69871.50ADB-SC.08.080.C	SK 50	8	80	21	27
69871.50ADB-SC.10.080.C	SK 50	10	80	24	32
69871.50ADB-SC.12.080.C	SK 50	12	80	24	32
69871.50ADB-SC.14.080.C	SK 50	14	80	27	34
69871.50ADB-SC.16.080.C	SK 50	16	80	27	34
69871.50ADB-SC.18.080.C	SK 50	18	80	33	42
69871.50ADB-SC.20.080.C	SK 50	20	80	33	42
69871.50ADB-SC.25.100.C	SK 50	25	100	44	53
69871.50ADB-SC.32.100.C	SK 50	32	100	44	53

Note: Toolholders suitable for induction-, contact- and hot air shrink units.
Ø 6 – Ø 32 with h6-tolerance



190

DIN 69871

ISO 60

MAS 403 BT

DIN 2080

HSK-A

VDI

MORSE



69871-IHA

HOLDERS FOR MILLING CUTTERS WITH THREADED END (EXCHANGEABLE HEAD)



Application:
For mounting screw-in cutters with thread.

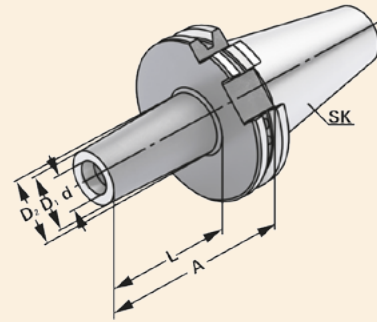

DIN 69871



$\nabla \leq 0,003$

G6,3
15.000 min⁻¹

Order no.	Taper	M	dH4	D ₁	D ₂	A	L
69871.40ADB-IHA.M6.025	SK 40	6	6,5	10	13	44	25
69871.40ADB-IHA.M6.050	SK 40	6	6,5	10	13	69	50
69871.40ADB-IHA.M6.075	SK 40	6	6,5	10	13	94	75
69871.40ADB-IHA.M8.025	SK 40	8	8,5	13	15	44	25
69871.40ADB-IHA.M8.050	SK 40	8	8,5	13	23	69	50
69871.40ADB-IHA.M8.075	SK 40	8	8,5	13	23	94	75
69871.40ADB-IHA.M8.100	SK 40	8	8,5	13	25	119	100
69871.40ADB-IHA.M10.005	SK 40	10	10,5	18	18	24	5
69871.40ADB-IHA.M10.025	SK 40	10	10,5	18	20	44	25
69871.40ADB-IHA.M10.050	SK 40	10	10,5	18	23	69	50
69871.40ADB-IHA.M10.075	SK 40	10	10,5	18	28	94	75
69871.40ADB-IHA.M10.100	SK 40	10	10,5	18	32	119	100
69871.40ADB-IHA.M10.150	SK 40	10	10,5	18	37	169	150
69871.40ADB-IHA.M12.005	SK 40	12	12,5	21	21	24	5
69871.40ADB-IHA.M12.025	SK 40	12	12,5	21	24	44	25
69871.40ADB-IHA.M12.050	SK 40	12	12,5	21	24	69	50
69871.40ADB-IHA.M12.075	SK 40	12	12,5	21	31	94	75
69871.40ADB-IHA.M12.100	SK 40	12	12,5	21	33	119	100
69871.40ADB-IHA.M12.150	SK 40	12	12,5	21	40	169	150
69871.40ADB-IHA.M16.005	SK 40	16	17	29	29	24	5
69871.40ADB-IHA.M16.025	SK 40	16	17	29	29	44	25
69871.40ADB-IHA.M16.050	SK 40	16	17	29	34	69	50
69871.40ADB-IHA.M16.075	SK 40	16	17	29	34	94	75
69871.40ADB-IHA.M16.100	SK 40	16	17	29	36	119	100
69871.40ADB-IHA.M16.150	SK 40	16	17	29	43	169	150
69871.50ADB-IHA.M8.050	SK 50	8	8,5	13	23	69	50
69871.50ADB-IHA.M8.100	SK 50	8	8,5	13	25	119	100
69871.50ADB-IHA.M8.150	SK 50	8	8,5	13	30	169	150
69871.50ADB-IHA.M10.050	SK 50	10	10,5	18	23	69	50
69871.50ADB-IHA.M10.100	SK 50	10	10,5	18	32	119	100
69871.50ADB-IHA.M10.150	SK 50	10	10,5	18	37	169	150
69871.50ADB-IHA.M12.050	SK 50	12	12,5	21	24	69	50
69871.50ADB-IHA.M12.100	SK 50	12	12,5	21	33	119	100

Order no.	Taper	M	dH4	D ₁	D ₂	A	L
69871.50ADB-IHA.M12.150	SK 50	12	12,5	21	40	169	150
69871.50ADB-IHA.M16.050	SK 50	16	17	29	34	69	50
69871.50ADB-IHA.M16.100	SK 50	16	17	29	36	119	100
69871.50ADB-IHA.M16.150	SK 50	16	17	29	43	169	150



190

69871-BLANKS

BLANKS FOR SPECIAL HOLDERS



Application:
For the manufacturing of special tools.

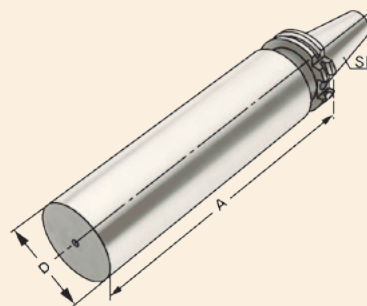

DIN 69871

Form
A

Order no.	Taper	D	A
69871.30A-BLA.40.160	SK 30	40,5	160
69871.40A-BLA.63.250	SK 40	63	250
69871.50A-BLA.97.315	SK 50	97	315



190

Version:

Cone and flange hardened and grinded. Soft body for later processing.

DIN 69871

ISO 60

MAS 403 BT

DIN 2080

HSK-A

VDI

MORSE



69871-TA

TEST ARBORS



Application:

For the inspection of machine tools according to ISO recommendation R230 or for testing the tool spindle.

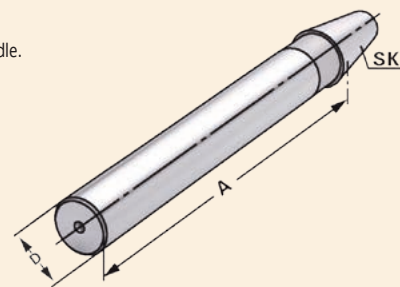

DIN 69871

Form A

$\nabla \leq 0,003$

Order no. Taper A D Tolerances Max. concentricity deviation

69871.30A-TA.32.300	SK 30	300	32	0,003	0,003
69871.40A-TA.40.300	SK 40	300	40	0,003	0,003
69871.50A-TA.50.300	SK 50	300	50	0,003	0,003

Delivery: **Delivery with test certificate**

DIN 69871

ISO 60

MAS 403 BT

DIN 2080

HSK-A

VDI

MORSE



ISO 60



Toolholders DIN 69871

DIN 69871

ISO 60

MAS 403 BT

DIN 2080

HSK-A

VDI

MORSE

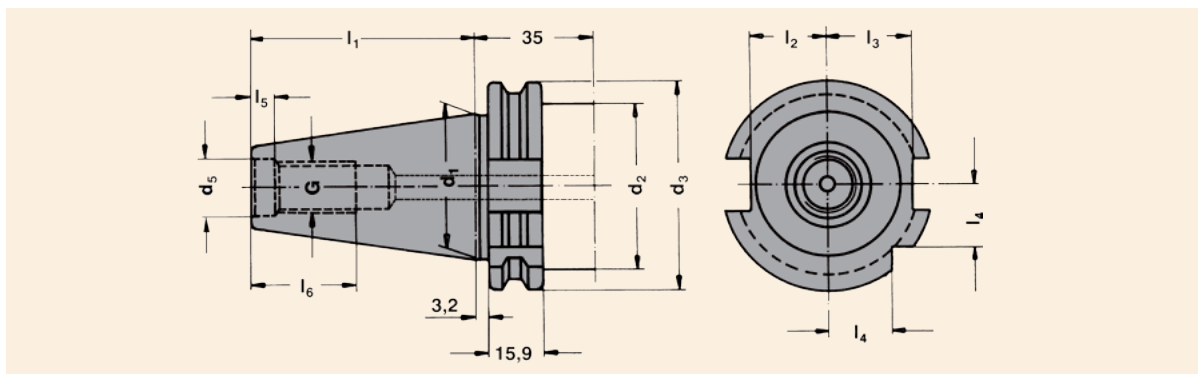

SK	d_1	G	d_5	d_2	d_3	l_1	l_2	l_3	l_4	l_5	l_6	d_6	e
60	107,95	M30	32	130	155	161,80	54,2	59,3	49	14	59	-	-



ISO-60-FMH1



40

ISO-60-MT



40

ISO-60-MTS



41

ISO-60-RED-ISO



41

DIN 69871

ISO 60

MAS 403 BT

DIN 2080

HSK-A

VDI

MORSE



ISO-60-FMH1

SHELL MILL HOLDERS

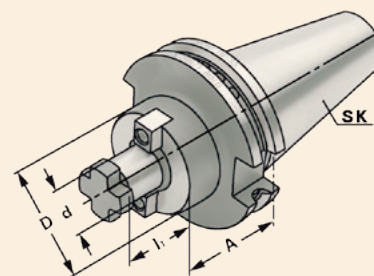
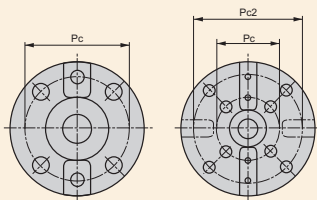

DIN 69871

Form
A

$\nabla \leq 0,005$

Order no.	SK	dh6	A	l_1	D	PC	PC2
69871.60A-FMH1.40.100	SK 60	40	100	25	90	66,7	
69871.60A-FMH1.40.250	SK 60	40	250	25	90	66,7	
69871.60A-FMH1.60.100	SK 60	60	100	40	130	101,6	
69871.60A-FMH1.60.250	SK 60	60	250	40	130	101,6	
69871.60A-FMH1.60.100-HD	SK 60	60	100	40	220	101,6	177,8

ISO-60-MT

HOLDERS FOR MORSE TAPER

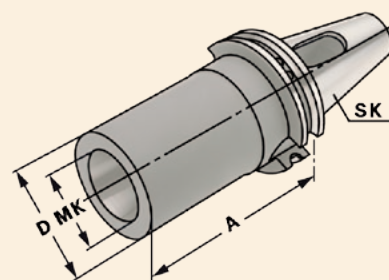

DIN 69871

Form
A

$\nabla \leq 0,005$

Order no.	SK	MK	A	D
69871.60A-MT.4.180	SK 60	4	180	48
69871.60A-MT.5.230	SK 60	5	230	60
69871.60A-MT.6.310	SK 60	6	310	90

DIN 69871

ISO 60

MAS 403 BT

DIN 2080

HSK-A

VDI

MORSE



ISO-60-MTS

HOLDERS FOR MORSE TAPER WITH DRAWBAR THREAD

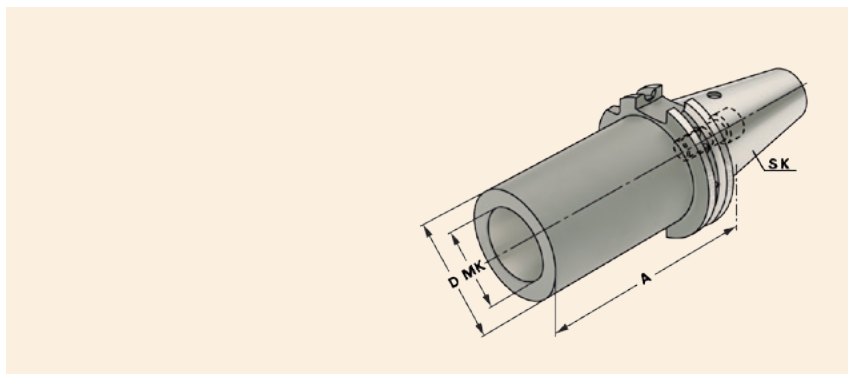

DIN 69871

Form
A

$\nabla \leq 0,005$

Order no.	SK	MTS	M	A	D
69871.60A-MTS.4.090	SK 60	4	M16	90	48
69871.60A-MTS.5.120	SK 60	5	M20	120	60
69871.60A-MTS.6.250	SK 60	6	M24	250	90

ISO-60-RED-ISO

REDUCTIONS FOR ISO CONE

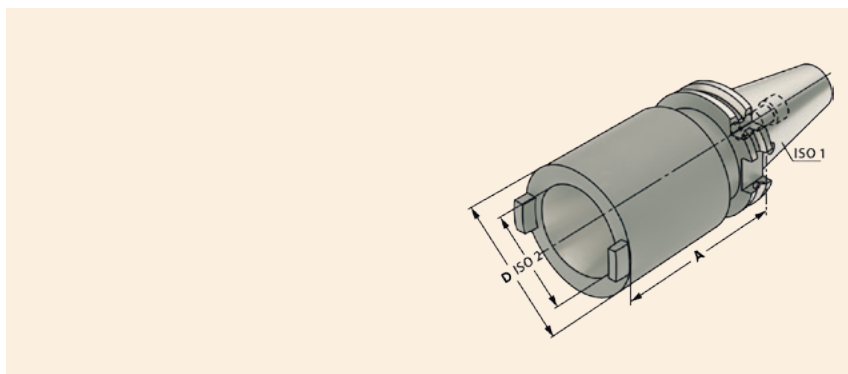

DIN 69871

Form
A

$\nabla \leq 0,005$

Order no.	ISO 1	ISO 2	A	D
69871.60A-RED.ISO.50.100	SK 60	ISO 50	100	100

DIN 69871

ISO 60

MAS 403 BT

DIN 2080

HSK-A

VDI

MORSE



MAS 403 BT

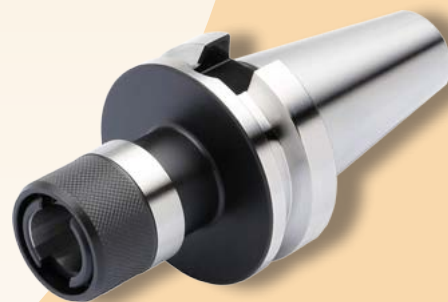

Toolholders JIS B 6339 (MAS 403 BT)

DIN 69871

ISO 60

MAS 403 BT

DIN 2080

HSK-A

VDI

MORSE

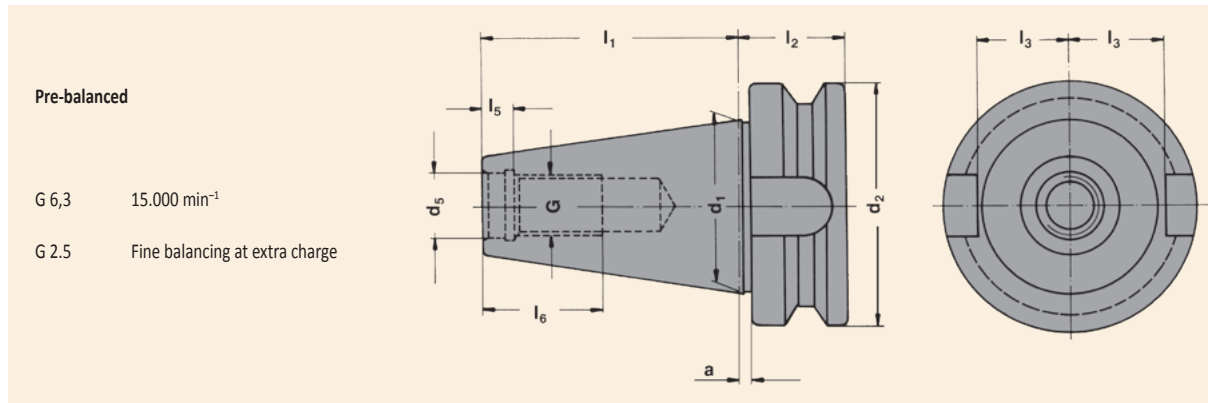

SK	d ₁	G	d ₅	d ₂	a	l ₁	l ₂	l ₃	l ₅	l ₆	e	d ₆
30	31,75	M12	12,5	46	2	48,4	22	16,3	7,0	24	–	–
40	44,45	M16	17,0	63	2	65,4	27	22,5	8,2	32	27	M4
50	69,85	M24	25,0	100	3	101,8	38	35,3	11,0	47	42	M6

With internal coolant through the collar - form AD/B

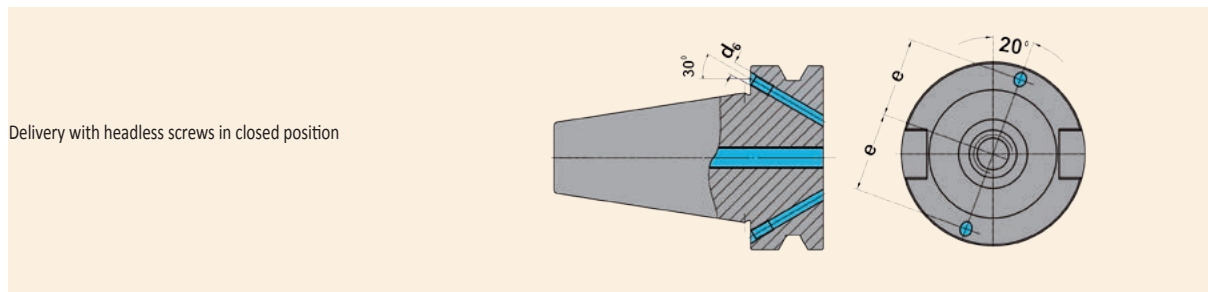

Material: Alloyed case-hardened steel, tensile core strength of min. 1200 N / mm². Case hardened HRC 60 ± 2 (HV 700 ± 50), hardening depth 0.8 mm ± 0.2 mm, black-finished and precisely grinded.

Form AD/B: Delivery in form AD, type B closed with releasable headless screws.

Accuracy: Quality of taper < AT 3 according to DIN 7187 and DIN 2080.



BT-CC-OZ



▣ 46

BT-CC-ER



▣ 47 - 49

BT-CCM-ER



▣ 50

BT-CC-HKS



▣ 51

BT-W



▣ 52 - 54

BT-W-C



▣ 55 - 56

BT-MT



▣ 57

BT-MTS



▣ 58

BT-RED-ISO



▣ 59

BT-FMH2



▣ 60 - 61

BT-FMH1



▣ 62 - 63

BT-FMH4



▣ 64

BT-DC



▣ 65

BT-QTCC



▣ 66

BT-QTCW



▣ 67

BT-HC



▣ 68 - 69

BT-SC



▣ 70 - 73

BT-SC-C



▣ 74

BT-IHA



▣ 75

BT-BLANKS



▣ 76

BT-TA



▣ 77

DIN 69871

ISO 60

MAS 403 BT

DIN 2080

HSK-A

VDI

MORSE



BT-CC-OZ

COLLET CHUCKS - OZ



Application:
For mounting straight-shank tools in collets.

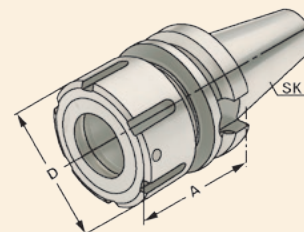

MAS 403 BT

JIS B 6339



$\nabla \leq 0,003$

G6,3
15.000 min⁻¹

Référence	Taper	Range		
BT.30AD-CC.OZ16.060	BT 30	2 – 16 (OZ 16)	60	43
BT.30AD-CC.OZ25.060	BT 30	2 – 25 (OZ 25)	80	60
BT.40ADB-CC.OZ16.070	BT 40	2 – 16 (OZ 16)	70	43
BT.40ADB-CC.OZ25.070	BT 40	2 – 25 (OZ 25)	70	60
BT.40ADB-CC.OZ32.090	BT 40	3 – 32 (OZ 32)	90	72
BT.50ADB-CC.OZ25.085	BT 50	2 – 25 (OZ 25)	85	60
BT.50ADB-CC.OZ32.090	BT 50	3 – 32 (OZ 32)	90	72

Delivery: **With ball bearing clamping nut**



DIN 69871

ISO 60

MAS 403 BT

DIN 2080

HSK-A

VDI

MORSE



BT-CC-ER

COLLET CHUCKS - ER



Application:
For mounting straight-shank tools in collets.

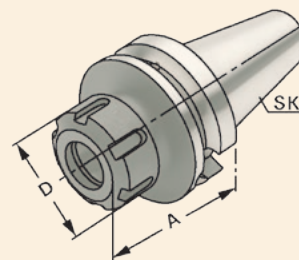

MAS 403 BT

JIS B 6339



$\nabla \leq 0,003$

G6,3
15.000 min⁻¹

Order no.	Taper	Range	A	D
BT.30AD-CC.ER16.070	BT 30	1 – 10 (ER 16)	70	32
BT.30AD-CC.ER25.070	BT 30	2 – 16 (ER 25)	70	42
BT.30AD-CC.ER32.070	BT 30	2 – 20 (ER 32)	70	50
BT.30AD-CC.ER40.070	BT 30	3 – 26 (ER 40)	70	63
BT.30AD-CC.ER16.100	BT 30	1 – 10 (ER 16)	100	32
BT.30AD-CC.ER25.100	BT 30	2 – 16 (ER 25)	100	42
BT.30AD-CC.ER32.100	BT 30	2 – 20 (ER 32)	100	50
BT.40AD-CC.ER16.063	BT 40	1 – 10 (ER 16)	63	32
BT.40AD-CC.ER25.060	BT 40	2 – 16 (ER 25)	60	42
BT.40AD-CC.ER32.070	BT 40	2 – 20 (ER 32)	70	50
BT.40AD-CC.ER40.080	BT 40	3 – 26 (ER 40)	80	63
BT.40AD-CC.ER16.100	BT 40	1 – 10 (ER 16)	100	32
BT.40AD-CC.ER25.100	BT 40	2 – 16 (ER 25)	100	42
BT.40AD-CC.ER32.100	BT 40	2 – 20 (ER 32)	100	50
BT.40AD-CC.ER40.100	BT 40	3 – 26 (ER 40)	100	63

Delivery: With balanced clamping nut



DIN 69871

ISO 60

MAS 403 BT

DIN 2080

HSK-A

VDI

MORSE



BT-CC-ER

COLLET CHUCKS - ER



Application:
For mounting straight-shank tools in collets.

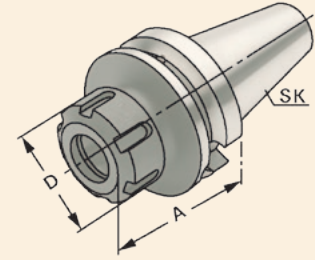

MAS 403 BT

JIS B 6339



$\nabla \leq 0,003$

G6,3
15.000 min⁻¹

Order no.	Taper	Range	A	D
BT.40ADB-CC.ER16.063	BT 40	1 – 10 (ER 16)	63	32
BT.40ADB-CC.ER25.060	BT 40	2 – 16 (ER 25)	60	42
BT.40ADB-CC.ER32.070	BT 40	2 – 20 (ER 32)	70	50
BT.40ADB-CC.ER40.080	BT 40	3 – 26 (ER 40)	80	63
BT.40ADB-CC.ER16.100	BT 40	1 – 10 (ER 16)	100	32
BT.40ADB-CC.ER25.100	BT 40	2 – 16 (ER 25)	100	42
BT.40ADB-CC.ER32.100	BT 40	2 – 20 (ER 32)	100	50
BT.40ADB-CC.ER40.100	BT 40	3 – 26 (ER 40)	100	63
BT.40ADB-CC.ER16.160	BT 40	1 – 10 (ER 16)	160	32
BT.40ADB-CC.ER25.160	BT 40	2 – 16 (ER 25)	160	42
BT.40ADB-CC.ER32.160	BT 40	2 – 20 (ER 32)	160	50
BT.40ADB-CC.ER40.160	BT 40	3 – 26 (ER 40)	160	63
BT.40ADB-CC.ER16.200	BT 40	1 – 10 (ER 16)	200	32
BT.40ADB-CC.ER25.200	BT 40	2 – 16 (ER 25)	200	42
BT.40ADB-CC.ER32.200	BT 40	2 – 20 (ER 32)	200	50
BT.40ADB-CC.ER40.200	BT 40	3 – 26 (ER 40)	200	63



200 - 219



241



192 - 193



235



236



237 - 239



BT-CC-ER

COLLET CHUCKS - ER



Application:
For mounting straight-shank tools in collets.

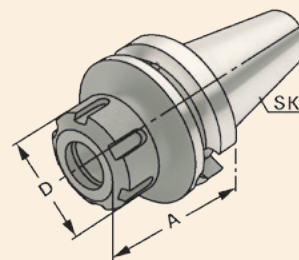

MAS 403 BT

JIS B 6339



$\nearrow \leq 0,003$

G6,3
15.000 min⁻¹

Order no.	Taper	Range	A	D
BT.50ADB-CC.ER25.070	BT 50	2 – 16 (ER 25)	70	42
BT.50ADB-CC.ER32.070	BT 50	2 – 20 (ER 32)	70	50
BT.50ADB-CC.ER40.080	BT 50	3 – 26 (ER 40)	80	63
BT.50ADB-CC.ER16.100	BT 50	1 – 10 (ER 16)	100	32
BT.50ADB-CC.ER25.100	BT 50	2 – 16 (ER 25)	100	42
BT.50ADB-CC.ER32.100	BT 50	2 – 20 (ER 32)	100	50
BT.50ADB-CC.ER40.100	BT 50	3 – 26 (ER 40)	100	63
BT.50ADB-CC.ER16.160	BT 50	1 – 10 (ER 16)	160	32
BT.50ADB-CC.ER25.160	BT 50	2 – 16 (ER 25)	160	42
BT.50ADB-CC.ER32.160	BT 50	2 – 20 (ER 32)	160	50
BT.50ADB-CC.ER40.160	BT 50	3 – 26 (ER 40)	160	63
BT.50ADB-CC.ER16.200	BT 50	1 – 10 (ER 16)	200	32
BT.50ADB-CC.ER25.200	BT 50	2 – 16 (ER 25)	200	42
BT.50ADB-CC.ER32.200	BT 50	2 – 20 (ER 32)	200	50
BT.50ADB-CC.ER40.200	BT 50	3 – 26 (ER 40)	200	63



200 - 219



241



192 - 193



235



236



237 - 239

DIN 69871

ISO 60

MAS 403 BT

DIN 2080

HSK-A

VDI

MORSE



BT-CCM-ER

MINI COLLET CHUCKS - ER



Application:
For mounting straight-shank tools in collets.

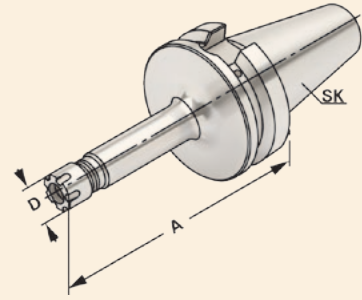

MAS 403 BT

JIS B 6339



$\nabla \leq 0,003$

G6,3
15.000 min⁻¹

Order no.	Taper	Range	A	D
BT.40ADB-CCM.ER11.063	BT 40	1 – 7 (ER 11)	55	16
BT.40ADB-CCM.ER11.100	BT 40	1 – 7 (ER 11)	100	16
BT.40ADB-CCM.ER11.160	BT 40	1 – 7 (ER 11)	160	16
BT.40ADB-CCM.ER16.055	BT 40	1 – 10 (ER 16)	55	22
BT.40ADB-CCM.ER16.100	BT 40	1 – 10 (ER 16)	100	22
BT.40ADB-CCM.ER16.160	BT 40	1 – 10 (ER 16)	160	22



BT-CC-HKS

HIGH PERFORMANCE CHUCKS - HKS



Application:

For mounting straight-shank tools acc. DIN 1835 form A+B+E and DIN 6535 form HA+HB+HE (smaller than dia. 20 mm or 32 mm only with reduction sleeve).

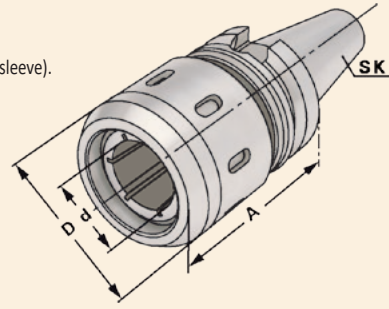

MAS 403 BT

JIS B 6339



$\nabla \leq 0,003$

G6,3
15.000 min⁻¹

Order no.	Taper	Range	A	D
BT.40ADB-CC.HKS20.090	BT 40	3-20 (HKS 20)	90	53
BT.40ADB-CC.HKS32.090	BT 40	3-32 (HKS 32)	90	68
BT.50ADB-CC.HKS20.095	BT 50	3-20 (HKS 20)	95	53
BT.50ADB-CC.HKS32.090	BT 50	3-32 (HKS 32)	90	68



DIN 69871

ISO 60

MAS 403 BT

DIN 2080

HSK-A

VDI

MORSE



BT-W

WELDON END MILL HOLDERS



Application:

For mounting straight-shank tools with flat according to DIN 1835 form B (Weldon).

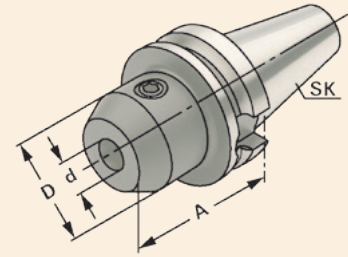

MAS 403 BT

JIS B 6339



Form AD

$\nabla \leq 0,003$

G6,3
15.000 min⁻¹

Order no.	Taper	dH4	A	D
BT.30AD-W.06.050	BT 30	6	50	25
BT.30AD-W.08.050	BT 30	8	50	28
BT.30AD-W.10.050	BT 30	10	50	35
BT.30AD-W.12.050	BT 30	12	50	42
BT.30AD-W.14.050	BT 30	14	50	44
BT.30AD-W.16.063	BT 30	16	63	48
BT.30AD-W.18.063	BT 30	18	63	50
BT.30AD-W.20.063	BT 30	20	63	52
BT.40AD-W.06.050	BT 40	6	50	25
BT.40AD-W.08.050	BT 40	8	50	28
BT.40AD-W.10.063	BT 40	10	63	35
BT.40AD-W.12.063	BT 40	12	63	42
BT.40AD-W.14.063	BT 40	14	63	44
BT.40AD-W.16.063	BT 40	16	63	48
BT.40AD-W.18.063	BT 40	18	63	50
BT.40AD-W.20.063	BT 40	20	63	52
BT.40AD-W.25.090	BT 40	25	90	65
BT.40AD-W.32.100	BT 40	32	100	72
BT.40AD-W.06.100	BT 40	6	100	25
BT.40AD-W.08.100	BT 40	8	100	28
BT.40AD-W.10.100	BT 40	10	100	35
BT.40AD-W.12.100	BT 40	12	100	42
BT.40AD-W.14.100	BT 40	14	100	44
BT.40AD-W.16.100	BT 40	16	100	48
BT.40AD-W.18.100	BT 40	18	100	50
BT.40AD-W.20.100	BT 40	20	100	52

Note: From d = 25 on two clamping screws

Delivery: With clamping screw



BT-W

WELDON END MILL HOLDERS



Application:
For mounting straight-shank tools with flat according to DIN 1835 form B (Weldon).

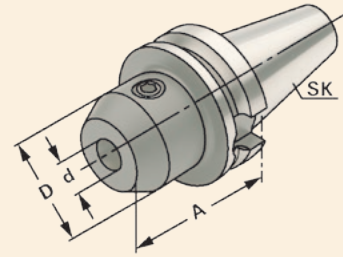

MAS 403 BT

JIS B 6339



$\nabla \leq 0,003$

G6,3
15.000 min⁻¹

Order no.	Taper	dH4	A	D
BT.40ADB-W.16.035	BT 40	16	35	45
BT.40ADB-W.20.035	BT 40	20	35	45
BT.40ADB-W.25.035	BT 40	25	35	55
BT.40ADB-W.32.065	BT 40	32	65	50
BT.40ADB-W.06.050	BT 40	6	50	25
BT.40ADB-W.08.050	BT 40	8	50	28
BT.40ADB-W.10.063	BT 40	10	63	35
BT.40ADB-W.12.063	BT 40	12	63	42
BT.40ADB-W.14.063	BT 40	14	63	44
BT.40ADB-W.16.063	BT 40	16	63	48
BT.40ADB-W.18.063	BT 40	18	63	50
BT.40ADB-W.20.063	BT 40	20	63	52
BT.40ADB-W.25.090	BT 40	25	90	65
BT.40ADB-W.32.100	BT 40	32	100	72
BT.40ADB-W.40.120	BT 40	40	120	80
BT.40ADB-W.06.100	BT 40	6	100	25
BT.40ADB-W.08.100	BT 40	8	100	28
BT.40ADB-W.10.100	BT 40	10	100	35
BT.40ADB-W.12.100	BT 40	12	100	42
BT.40ADB-W.14.100	BT 40	14	100	44
BT.40ADB-W.16.100	BT 40	16	100	48
BT.40ADB-W.18.100	BT 40	18	100	50
BT.40ADB-W.20.100	BT 40	20	100	52
BT.40ADB-W.06.160	BT 40	6	160	25
BT.40ADB-W.08.160	BT 40	8	160	28
BT.40ADB-W.10.160	BT 40	10	160	35
BT.40ADB-W.12.160	BT 40	12	160	42
BT.40ADB-W.14.160	BT 40	14	160	44
BT.40ADB-W.16.160	BT 40	16	160	48
BT.40ADB-W.18.160	BT 40	18	160	50
BT.40ADB-W.20.160	BT 40	20	160	52
BT.40ADB-W.25.160	BT 40	25	160	65
BT.40ADB-W.32.160	BT 40	32	160	72
BT.40ADB-W.40.160	BT 40	40	160	80

DIN 69871

ISO 60

MAS 403 BT

DIN 2080

HSK-A

VDI

MORSE



BT-W

WELDON END MILL HOLDERS



Application:
For mounting straight-shank tools with flat according to DIN 1835 form B (Weldon).

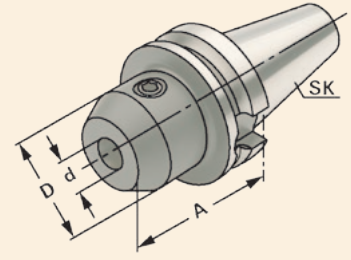

MAS 403 BT

JIS B 6339



$\nabla \leq 0,003$

G6,3
15.000 min⁻¹

Order no.	Taper	dH4	A	D
BT.50ADB-W.06.063	BT 50	6	63	25
BT.50ADB-W.08.063	BT 50	8	63	28
BT.50ADB-W.10.063	BT 50	10	63	35
BT.50ADB-W.12.080	BT 50	12	80	42
BT.50ADB-W.14.080	BT 50	14	80	44
BT.50ADB-W.16.080	BT 50	16	80	48
BT.50ADB-W.18.080	BT 50	18	80	50
BT.50ADB-W.20.080	BT 50	20	80	52
BT.50ADB-W.25.100	BT 50	25	100	65
BT.50ADB-W.32.105	BT 50	32	105	72
BT.50ADB-W.40.110	BT 50	40	110	80
BT.50ADB-W.06.100	BT 50	6	100	25
BT.50ADB-W.08.100	BT 50	8	100	28
BT.50ADB-W.10.100	BT 50	10	100	35
BT.50ADB-W.12.100	BT 50	12	100	42
BT.50ADB-W.14.100	BT 50	14	100	44
BT.50ADB-W.16.100	BT 50	16	100	48
BT.50ADB-W.18.100	BT 50	18	100	50
BT.50ADB-W.20.100	BT 50	20	100	52
BT.50ADB-W.06.160	BT 50	6	160	25
BT.50ADB-W.08.160	BT 50	8	160	28
BT.50ADB-W.10.160	BT 50	10	160	35
BT.50ADB-W.12.160	BT 50	12	160	42
BT.50ADB-W.14.160	BT 50	14	160	44
BT.50ADB-W.16.160	BT 50	16	160	48
BT.50ADB-W.18.160	BT 50	18	160	50
BT.50ADB-W.20.160	BT 50	20	160	52
BT.50ADB-W.25.160	BT 50	25	160	65
BT.50ADB-W.32.160	BT 50	32	160	72
BT.50ADB-W.40.160	BT 50	40	160	80

Note: From d = 25 on two clamping screws



Delivery: With clamping screw

192 - 193

245

DIN 69871

ISO 60

MAS 403 BT

DIN 2080

HSK-A

VDI

MORSE



BT-W-C

WELDON END MILL HOLDERS WITH COOLANT CHANNELS



Application:

For mounting straight-shank tools with flat according to DIN 1835 form B (Weldon).
With coolant channels for optimal coolant at the cutting edge.

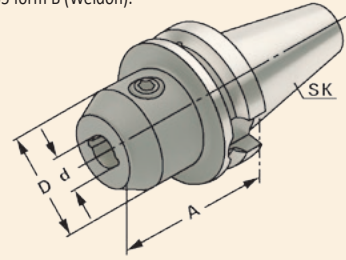

MAS 403 BT

JIS B 6339



$\nearrow \leq 0,003$

G6,3
15.000 min⁻¹

Order no.	Taper	dH4	A	D
BT.40ADB-W.06.050.C	BT 40	6	50	25
BT.40ADB-W.08.050.C	BT 40	8	50	28
BT.40ADB-W.10.063.C	BT 40	10	63	35
BT.40ADB-W.12.063.C	BT 40	12	63	42
BT.40ADB-W.14.063.C	BT 40	14	63	44
BT.40ADB-W.16.063.C	BT 40	16	63	48
BT.40ADB-W.18.063.C	BT 40	18	63	50
BT.40ADB-W.20.063.C	BT 40	20	63	52
BT.40ADB-W.25.090.C	BT 40	25	90	65
BT.40ADB-W.32.100.C	BT 40	32	100	72
BT.40ADB-W.40.120.C	BT 40	40	120	80
BT.40ADB-W.06.100.C	BT 40	6	100	25
BT.40ADB-W.08.100.C	BT 40	8	100	28
BT.40ADB-W.10.100.C	BT 40	10	100	35
BT.40ADB-W.12.100.C	BT 40	12	100	42
BT.40ADB-W.14.100.C	BT 40	14	100	44
BT.40ADB-W.16.100.C	BT 40	16	100	48
BT.40ADB-W.18.100.C	BT 40	18	100	50
BT.40ADB-W.20.100.C	BT 40	20	100	52

Note:

From d = 25 on two clamping screws
d = 6 to 14 with two coolant channels
d = 16 to 40 with four coolant channels
For tools with through coolant an O-ring must be used.



Delivery: With clamping screw and O-ring



DIN 69871

ISO 60

MAS 403 BT

DIN 2080

HSK-A

VDI

MORSE



BT-W-C

WELDON END MILL HOLDERS WITH COOLANT CHANNELS



Application:

For mounting straight-shank tools with flat according to DIN 1835 form B (Weldon).
With coolant channels for optimal coolant at the cutting edge.

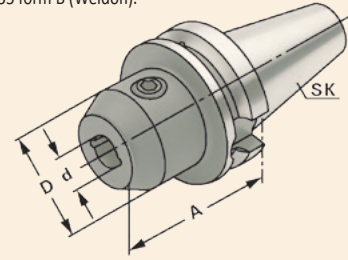

MAS 403 BT

JIS B 6339



$\nabla \leq 0,003$

G6,3
15.000 min⁻¹

Order no.	Taper	dH4	A	D
BT.50ADB-W.06.063.C	BT 50	6	63	25
BT.50ADB-W.08.063.C	BT 50	8	63	28
BT.50ADB-W.10.063.C	BT 50	10	63	35
BT.50ADB-W.12.080.C	BT 50	12	80	42
BT.50ADB-W.14.080.C	BT 50	14	80	44
BT.50ADB-W.16.080.C	BT 50	16	80	48
BT.50ADB-W.18.080.C	BT 50	18	80	50
BT.50ADB-W.20.080.C	BT 50	20	80	52
BT.50ADB-W.25.100.C	BT 50	25	100	65
BT.50ADB-W.32.105.C	BT 50	32	105	72
BT.50ADB-W.40.110.C	BT 50	40	110	80

Note:

From d = 25 on two clamping screws
d = 6 to 14 with two coolant channels
d = 16 to 40 with four coolant channels
For tools with through coolant an O-ring must be used.

Delivery: With clamping screw and O-ring



192 - 193

245

DIN 69871

ISO 60

MAS 403 BT

DIN 2080

HSK-A

VDI

MORSE



BT-MT

HOLDERS FOR MORSE TAPER



Application:
For mounting tools with Morse taper shank and tang according to DIN 228-1 form B.

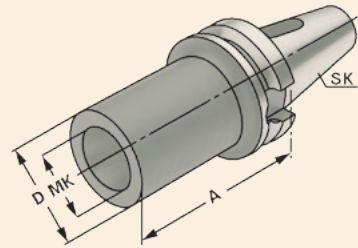

MAS 403 BT

JIS B 6339



$\nearrow \leq 0,005$

G6,3
15.000 min⁻¹

Order no.	Taper	MK	A	D
BT.30AD-MT.1.045	BT 30	1	45	25
BT.30AD-MT.2.060	BT 30	2	60	32
BT.30AD-MT.3.075	BT 30	3	75	40
BT.40AD-MT.1.050	BT 40	1	50	25
BT.40AD-MT.2.050	BT 40	2	50	32
BT.40AD-MT.3.070	BT 40	3	70	40
BT.40AD-MT.4.095	BT 40	4	95	48
BT.50ADB-MT.1.045	BT 50	1	45	25
BT.50ADB-MT.2.060	BT 50	2	60	32
BT.50ADB-MT.3.065	BT 50	3	65	40
BT.50ADB-MT.4.095	BT 50	4	95	48
BT.50ADB-MT.5.105	BT 50	5	105	63



DIN 69871

ISO 60

MAS 403 BT

DIN 2080

HSK-A

VDI

MORSE



BT-MTS

HOLDERS FOR MORSE TAPER WITH DRAWBAR THREAD



Application:

For clamping tools with Morse taper shank and thread according to DIN 228-1 form A.

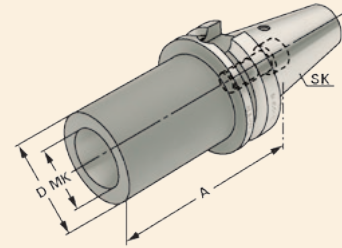

MAS 403 BT

JIS B 6339

Form A

$\nabla \leq 0,003$

G6,3
15.000 min⁻¹

Order no.	Taper	MK	M	A	D
BT.40A-MTS.1.050	BT 40	1	M6	50	25
BT.40A-MTS.2.050	BT 40	2	M10	50	32
BT.40A-MTS.3.070	BT 40	3	M12	70	40
BT.40A-MTS.4.095	BT 40	4	M16	95	48
BT.50A-MTS.1.045	BT 50	1	M6	45	25
BT.50A-MTS.2.060	BT 50	2	M10	60	32
BT.50A-MTS.3.065	BT 50	3	M12	65	40
BT.50A-MTS.4.070	BT 50	4	M16	70	48
BT.50A-MTS.5.100	BT 50	5	M20	100	63

Version: JIS B 6339 form A

Delivery: With built-in tightening bolt



192 - 193

DIN 69871

ISO 60

MAS 403 BT

DIN 2080

HSK-A

VDI

MORSE



BT-RED-ISO

REDUCTIONS FOR ISO CONE



Application:
For holding tapers according to DIN 69871,
JIS B 6339 and DIN 2080.

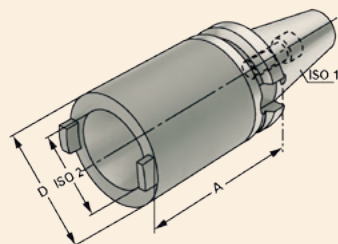

- MAS 403 BT
- JIS B 6339
- Form A
- $\nabla \leq 0,005$
- G6,3 15.000 min⁻¹

Order no.	ISO 1	ISO 2	A	D
BT.40A-RED-ISO30.060	BT 40	ISO 30	60	63
BT.40A-RED-ISO40.100	BT 40	ISO 40	100	63
BT.50A-RED-ISO40.070	BT 50	ISO 40	70	70
BT.50A-RED-ISO50.120	BT 50	ISO 50	120	97

Note: Delivered with a built-in screw for shortened taper tools. Additional screw for DIN 2080 tools included.



DIN 69871

ISO 60

MAS 403 BT

DIN 2080

HSK-A

VDI

MORSE

BT-FMH2

COMBI SHELL MILL HOLDERS



Application:
For mounting milling cutters with transverse or longitudinal groove.

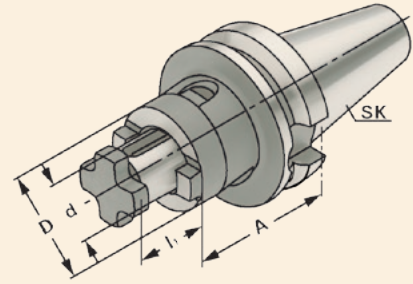

MAS 403 BT

JIS B 6339



$\nabla \leq 0,005$

G6,3
15.000 min⁻¹

Order no.	Taper	dh6	A	l ₁	D
BT.30AD-FMH2.16.045	BT 30	16	45	17	32
BT.30AD-FMH2.22.047	BT 30	22	47	19	40
BT.30AD-FMH2.27.049	BT 30	27	49	21	48
BT.40ADB-FMH2.16.055	BT 40	16	55	17	32
BT.40ADB-FMH2.22.055	BT 40	22	55	19	40
BT.40ADB-FMH2.27.055	BT 40	27	55	21	48
BT.40ADB-FMH2.32.060	BT 40	32	60	24	58
BT.40ADB-FMH2.40.060	BT 40	40	60	27	70
BT.40ADB-FMH2.16.100	BT 40	16	100	17	32
BT.40ADB-FMH2.22.100	BT 40	22	100	19	40
BT.40ADB-FMH2.27.100	BT 40	27	100	21	48
BT.40ADB-FMH2.32.100	BT 40	32	100	24	58
BT.40ADB-FMH2.40.100	BT 40	40	100	27	70
BT.40ADB-FMH2.16.160	BT 40	16	160	17	32
BT.40ADB-FMH2.22.160	BT 40	22	160	19	40
BT.40ADB-FMH2.27.160	BT 40	27	160	21	48
BT.40ADB-FMH2.32.160	BT 40	32	160	24	58
BT.40ADB-FMH2.40.160	BT 40	40	160	27	70

Delivery: With tightening bolt, driving ring and feather key



BT-FMH2

COMBI SHELL MILL HOLDERS



Application:
For mounting milling cutters with transverse or longitudinal groove.

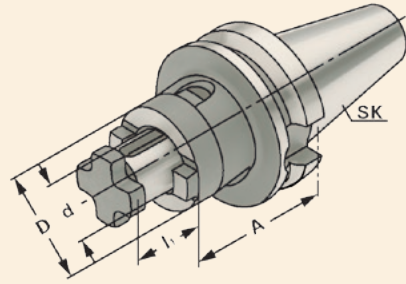

MAS 403 BT

JIS B 6339



$\nabla \leq 0,005$

G6,3
15.000 min⁻¹

Order no.	Taper	dh6	A	l ₁	D
BT.50ADB-FMH2.16.070	BT 50	16	70	17	32
BT.50ADB-FMH2.22.070	BT 50	22	70	19	40
BT.50ADB-FMH2.27.070	BT 50	27	70	21	48
BT.50ADB-FMH2.32.070	BT 50	32	70	24	58
BT.50ADB-FMH2.40.070	BT 50	40	70	27	70
BT.50ADB-FMH2.16.160	BT 50	16	160	17	32
BT.50ADB-FMH2.22.160	BT 50	22	160	19	40
BT.50ADB-FMH2.27.160	BT 50	27	160	21	48
BT.50ADB-FMH2.32.160	BT 50	32	160	24	58
BT.50ADB-FMH2.40.160	BT 50	40	160	27	70

Delivery: With tightening bolt, driving ring and feather key



DIN 69871

ISO 60

MAS 403 BT

DIN 2080

HSK-A

VDI

MORSE



BT-FMH1

SHELL MILL HOLDERS



Application:
For mounting milling cutters with transversal groove.

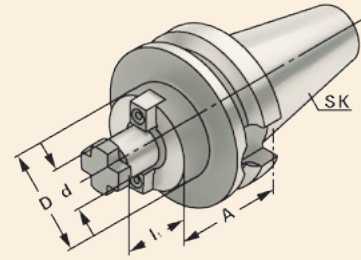

MAS 403 BT

JIS B 6339



$\nabla \leq 0,005$

G6,3
15.000 min⁻¹

Order no.	Taper	dh6	A	l ₁	D
BT.30AD-FMH1.16.040	BT 30	16	40	17	38
BT.30AD-FMH1.22.040	BT 30	22	40	19	48
BT.30AD-FMH1.27.040	BT 30	27	40	21	58
BT.30AD-FMH1.32.050	BT 30	32	50	24	78
BT.40ADB-FMH1.16.040	BT 40	16	40	17	38
BT.40ADB-FMH1.22.040	BT 40	22	40	19	48
BT.40ADB-FMH1.27.040	BT 40	27	40	21	58
BT.40ADB-FMH1.32.050	BT 40	32	50	24	78
BT.40ADB-FMH1.40.050	BT 40	40	50	27	88
BT.40ADB-FMH1.16.100	BT 40	16	100	17	38
BT.40ADB-FMH1.22.100	BT 40	22	100	19	48
BT.40ADB-FMH1.27.100	BT 40	27	100	21	58
BT.40ADB-FMH1.32.100	BT 40	32	100	24	78
BT.40ADB-FMH1.40.100	BT 40	40	100	27	88
BT.40ADB-FMH1.16.160	BT 40	16	160	17	38
BT.40ADB-FMH1.22.160	BT 40	22	160	19	48
BT.40ADB-FMH1.27.160	BT 40	27	160	21	58
BT.40ADB-FMH1.32.160	BT 40	32	160	24	78
BT.40ADB-FMH1.40.160	BT 40	40	160	27	88

BT 30 without coolant exit bores on the end face d = 40:

For large diameter face mill cutters with four additional threaded holes according to DIN 2079.

Delivery: With drivers, cross head retaining screw and cylinder head retaining screw for cutters with central coolant.



242

243 - 244

192 - 193

DIN 69871

ISO 60

MAS 403 BT

DIN 2080

HSK-A

VDI

MORSE



BT-FMH1

SHELL MILL HOLDERS



Application:
For mounting milling cutters with transversal groove.

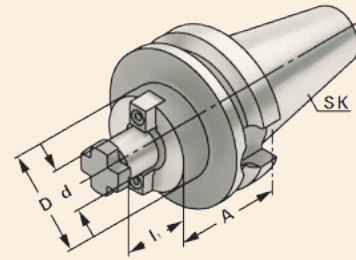

MAS 403 BT

JIS B 6339



$\nearrow \leq 0,005$

G6,3
15.000 min⁻¹

Order no.	Taper	dh6	A	l ₁	D
BT.50ADB-FMH1.22.040	BT 50	22	40	19	48
BT.50ADB-FMH1.27.040	BT 50	27	40	21	58
BT.50ADB-FMH1.32.050	BT 50	32	50	24	78
BT.50ADB-FMH1.40.050	BT 50	40	50	27	88
BT.50ADB-FMH1.60.080	BT 50	60	80	40	129
BT.50ADB-FMH1.22.100	BT 50	22	100	19	48
BT.50ADB-FMH1.27.100	BT 50	27	100	21	58
BT.50ADB-FMH1.32.100	BT 50	32	100	24	78
BT.50ADB-FMH1.40.100	BT 50	40	100	27	88
BT.50ADB-FMH1.22.160	BT 50	22	160	19	48
BT.50ADB-FMH1.27.160	BT 50	27	160	21	58
BT.50ADB-FMH1.32.160	BT 50	32	160	24	78
BT.50ADB-FMH1.40.160	BT 50	40	160	27	88
BT.50ADB-FMH1.60.160	BT 50	60	160	40	129
BT.50ADB-FMH1.27.200	BT 50	27	200	21	58
BT.50ADB-FMH1.32.200	BT 50	32	200	24	78
BT.50ADB-FMH1.40.200	BT 50	40	200	27	88
BT.50ADB-FMH1.60.200	BT 50	60	200	40	129

d = 40/d = 60: For large diameter face mill cutters with four additional threaded holes according to DIN 2079.

Delivery: With drivers, cross head retaining screw and cylinder head retaining screw for cutters with central coolant.
For d = 60 only with four fixation screws according to DIN 912.



DIN 69871

ISO 60

MAS 403 BT

DIN 2080

HSK-A

VDI

MORSE



BT-FMH4

HOLDERS FOR DISC MILLING CUTTERS



Application:
For mounting disc milling cutters.

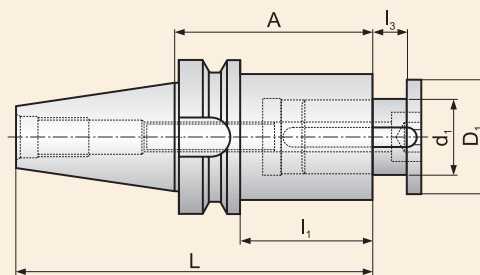

MAS 403 BT

JIS B 6339

Form A

$\nabla \leq 0,005$

G6,3
15.000 min⁻¹

Order no.	Taper	d ₁	A	L	l ₁	l ₃	D ₁
BT.40A-FMH4.27.075	BT 40	27	75	140,4	48	0-15	42
BT.40A-FMH4.32.090	BT 40	32	90	155,4	63	0-24	48
BT.50A-FMH4.40.120	BT 50	40	120	221,8	82	0-30	58
BT.50A-FMH4.50.145	BT 50	50	145	246,8	107	0-32	72
BT.50A-FMH4.60.180	BT 50	60	180	281,8	142	0-40	90

Delivery: With drive shafts, screws and hexagonal key.



DIN 69871

ISO 60

MAS 403 BT

DIN 2080

HSK-A

VDI

MORSE



BT-DC

DRILL CHUCK HOLDERS



Application:
For mounting tools with straight shanks.

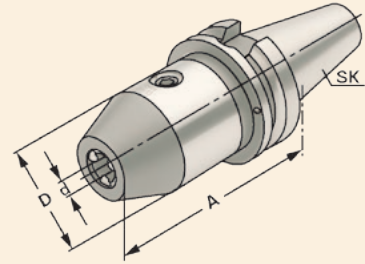

MAS 403 BT

JIS B 6339



$\nabla \leq 0,03$

G6,3
15.000 min⁻¹

Order no.	Taper	Range	A	D
BT.30AD-DC.08.073	BT 30	0,5 – 8	73	36
BT.30AD-DC.13.093	BT 30	1 – 13	93	50
BT.30AD-DC.16.098	BT 30	2,5 – 16	98	50
BT.40AD-DC.08.078	BT 40	0,5 – 8	78	36
BT.40AD-DC.13.098	BT 40	1 – 13	98	50
BT.40AD-DC.16.103	BT 40	2,5 – 16	103	50
BT.50AD-DC.13.108	BT 50	1 – 13	108	50
BT.50AD-DC.16.114	BT 50	2,5 – 16	114	50

Note: High precision and accurate concentricity of ≤ 0.03 mm. Secure gripping of the tool through mechanical amplification of the clamping force. No automatic slackening of the clamping force while machining with either clockwise or counter clockwise rotation or on spindle stop. Clamping and releasing effected by means of an Allen wrench.

Delivery: With wrench



192 - 193

DIN 69871

ISO 60

MAS 403 BT

DIN 2080

HSK-A

VDI

MORSE



BT-QTCC

QUICK-CHANGE TAPPING CHUCKS WITH COMPENSATION



Application:
For the chucking of quick change adaptors for taps.

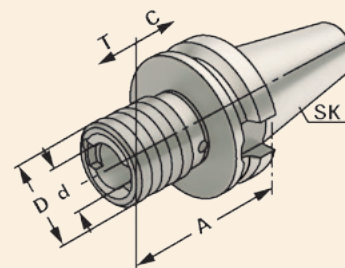

MAS 403 BT

JIS B 6339

Form A

Order no.	Taper	Range	Size					
BT.30A-QTCC.M3.M14	BT 30	M3 – M14	1	62	38	19	7	7
BT.30A-QTCC.M5.M22	BT 30	M5 – M22	2	95	54	31	12	12
BT.40A-QTCC.M3.M14	BT 40	M3 – M14	1	65	38	19	7	7
BT.40A-QTCC.M5.M22	BT 40	M5 – M22	2	93	54	31	12	12
BT.40A-QTCC.M14.M36	BT 40	M14 – M36	3	166	78	48	20	20
BT.50A-QTCC.M3.M14	BT 50	M3 – M14	1	100	38	19	7	7
BT.50A-QTCC.M5.M22	BT 50	M5 – M22	2	100	54	31	12	12
BT.50A-QTCC.M14.M36	BT 50	M14 – M36	3	142	78	48	17,5	17,5

Note: For machining centres without synchronous spindle.



222 - 224

225 - 227

228

192 - 193

DIN 69871

ISO 60

MAS 403 BT

DIN 2080

HSK-A

VDI

MORSE



BT-QTCW

QUICK-CHANGE TAPPING CHUCKS WITHOUT COMPENSATION



Application:
For the chucking of quick change adaptors for taps.

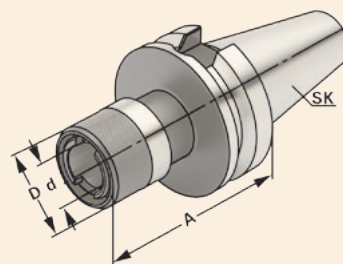

MAS 403 BT

JIS B 6339



Order no.	Taper	Range	Size	A	D	d
BT.30AD-QTCW.M3.M14	BT 30	M3 – M14	1	66	38	19
BT.30AD-QTCW.M5.M22	BT 30	M5 – M22	2	80	54	31
BT.40AD-QTCW.M3.M14	BT 40	M3 – M14	1	72	38	19
BT.40AD-QTCW.M5.M22	BT 40	M5 – M22	2	93	54	31
BT.40AD-QTCW.M14.M36	BT 40	M14 – M36	3	130	78	48
BT.50AD-QTCW.M3.M14	BT 50	M3 – M14	1	80	38	19
BT.50AD-QTCW.M5.M22	BT 50	M5 – M22	2	95	54	31
BT.50AD-QTCW.M14.M36	BT 50	M14 – M36	3	142	78	48

Note: For machining centres with synchronous spindle.



DIN 69871

ISO 60

MAS 403 BT

DIN 2080

HSK-A

VDI

MORSE



BT-HC

HYDRAULIC CHUCKS



Application:

For mounting straight-shank tools acc. DIN 1835 form A+B+E and DIN 6535 form HA+HB+HE (for dia. 20 mm or 32 mm reduction sleeve can be used).

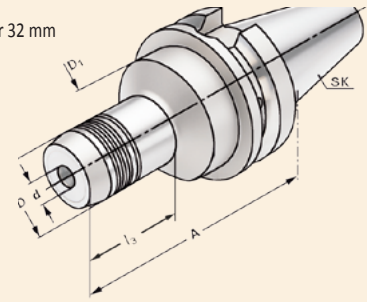

MAS 403 BT

JIS B 6339



$\nabla \leq 0,003$

G6,3
15.000 min⁻¹

Order no.	Taper	d	A	D	D ₁	l ₃
BT.30AD-HC.06.060	BT 30	6	60	26	45	33
BT.30AD-HC.08.064	BT 30	8	64	28	45	29
BT.30AD-HC.10.064	BT 30	10	64	30	45	37
BT.30AD-HC.12.072	BT 30	12	72	32	45	43
BT.30AD-HC.14.070	BT 30	14	70	34	45	45
BT.30AD-HC.16.090	BT 30	16	90	38	45	47
BT.30AD-HC.18.090	BT 30	18	90	40	45	68
BT.30AD-HC.20.090	BT 30	20	90	42	45	68
BT.40ADB-HC.06.090	BT 40	6	90	26	50	43
BT.40ADB-HC.08.090	BT 40	8	90	28	50	43,5
BT.40ADB-HC.10.090	BT 40	10	90	30	50	44
BT.40ADB-HC.12.090	BT 40	12	90	32	50	44,5
BT.40ADB-HC.14.090	BT 40	14	90	34	50	47,5
BT.40ADB-HC.16.090	BT 40	16	90	38	50	47,5
BT.40ADB-HC.18.090	BT 40	18	90	40	50	47,5
BT.40ADB-HC.20.090	BT 40	20	90	42	50	47,5
BT.40ADB-HC.25.090	BT 40	25	90	50	63	51
BT.40ADB-HC.32.110	BT 40	32	110	60	60	81,5
BT.40ADB-HC.06.150	BT 40	6	150	26	50	102
BT.40ADB-HC.08.150	BT 40	8	150	28	50	103
BT.40ADB-HC.10.150	BT 40	10	150	30	50	104
BT.40ADB-HC.12.150	BT 40	12	150	32	50	105
BT.40ADB-HC.14.150	BT 40	14	150	34	50	105
BT.40ADB-HC.16.150	BT 40	16	150	38	50	106
BT.40ADB-HC.18.150	BT 40	18	150	40	50	107
BT.40ADB-HC.20.150	BT 40	20	150	42	50	108
BT.40ADB-HC.25.150	BT 40	25	150	50	50	123
BT.40ADB-HC.32.150	BT 40	32	150	60	50	123

Delivery: With wrench



221

220

192 - 193



BT-HC

HYDRAULIC CHUCKS



Application:

For mounting straight-shank tools acc. DIN 1835 form A+B+E and DIN 6535 form HA+HB+HE (for dia. 20 mm or 32 mm reduction sleeve can be used).

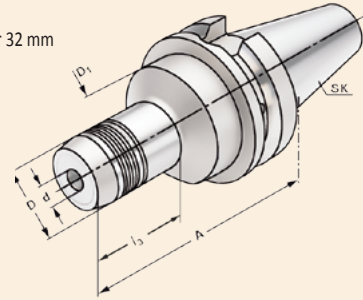

MAS 403 BT

JIS B 6339



$\nabla \leq 0,003$

G6,3
15.000 min⁻¹

Order no.	Taper	d	A	D	D ₁	l ₃
BT.40ADB-HC.06.200	BT 40	6	200	26	50	152
BT.40ADB-HC.08.200	BT 40	8	200	28	50	153
BT.40ADB-HC.10.200	BT 40	10	200	30	50	154
BT.40ADB-HC.12.200	BT 40	12	200	32	50	155
BT.40ADB-HC.14.200	BT 40	14	200	34	50	155
BT.40ADB-HC.16.200	BT 40	16	200	38	50	156
BT.40ADB-HC.18.200	BT 40	18	200	40	50	157
BT.40ADB-HC.20.200	BT 40	20	200	42	50	158
BT.40ADB-HC.25.200	BT 40	25	200	50	50	173
BT.40ADB-HC.32.200	BT 40	32	200	60	50	173
BT.50ADB-HC.06.110	BT 50	6	110	26	80	43
BT.50ADB-HC.08.110	BT 50	8	110	28	80	43,5
BT.50ADB-HC.10.110	BT 50	10	110	30	80	44
BT.50ADB-HC.12.110	BT 50	12	110	32	80	42
BT.50ADB-HC.14.110	BT 50	14	110	34	80	42
BT.50ADB-HC.16.110	BT 50	16	110	38	80	45
BT.50ADB-HC.18.110	BT 50	18	110	40	80	45
BT.50ADB-HC.20.110	BT 50	20	110	42	80	47,5
BT.50ADB-HC.25.110	BT 50	25	110	50	80	47,5
BT.50ADB-HC.32.110	BT 50	32	110	60	80	47,5

Delivery: With wrench



221

220

192 - 193

DIN 69871

ISO 60

MAS 403 BT

DIN 2080

HSK-A

VDI

MORSE



BT-SC

SHRINK FIT HOLDERS



Application:
For mounting straight-shank tools.

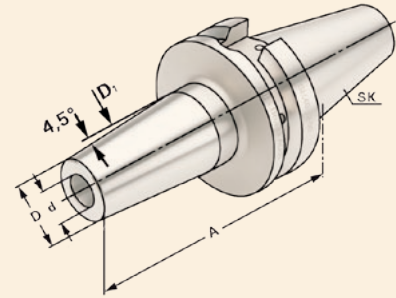

MAS 403 BT

JIS B 6339



$\nabla \leq 0,003$

G6,3
15.000 min⁻¹

Order no.	Taper	d	A	D	D ₁
BT.30AD-SC.03.080	BT 30	3	80	11	15
BT.30AD-SC.04.080	BT 30	4	80	14	22
BT.30AD-SC.05.080	BT 30	5	80	16	22
BT.30AD-SC.06.080	BT 30	6	80	21	27
BT.30AD-SC.08.080	BT 30	8	80	21	27
BT.30AD-SC.10.090	BT 30	10	90	24	32
BT.30AD-SC.12.090	BT 30	12	90	24	32
BT.30AD-SC.14.090	BT 30	14	90	27	34
BT.30AD-SC.16.090	BT 30	16	90	27	34
BT.30AD-SC.18.090	BT 30	18	90	33	42
BT.30AD-SC.20.090	BT 30	20	90	33	42
BT.30AD-SC.25.100	BT 30	25	100	44	53
BT.40ADB-SC.03.080	BT 40	3	80	11	15
BT.40ADB-SC.04.080	BT 40	4	80	14	22
BT.40ADB-SC.05.080	BT 40	5	80	16	22
BT.40ADB-SC.06.090	BT 40	6	90	21	27
BT.40ADB-SC.08.090	BT 40	8	90	21	27
BT.40ADB-SC.10.090	BT 40	10	90	24	32
BT.40ADB-SC.12.090	BT 40	12	90	24	32
BT.40ADB-SC.14.090	BT 40	14	90	27	34
BT.40ADB-SC.16.090	BT 40	16	90	27	34
BT.40ADB-SC.18.090	BT 40	18	90	33	42
BT.40ADB-SC.20.090	BT 40	20	90	33	42
BT.40ADB-SC.25.100	BT 40	25	100	44	53
BT.40ADB-SC.32.100	BT 40	32	100	44	53

For \varnothing 3, 4 and 5 mm only solid carbide tool shanks must be used!

Note: Toolholders suitable for induction-, contact- and hot air shrink units.
 \varnothing 3, 4, 5 with h4-tolerance and \varnothing 6 – \varnothing 32 with h6-tolerance



192 - 193

DIN 69871

ISO 60

MAS 403 BT

DIN 2080

HSK-A

VDI

MORSE



BT-SC

SHRINK FIT HOLDERS



Application:
For mounting straight-shank tools.

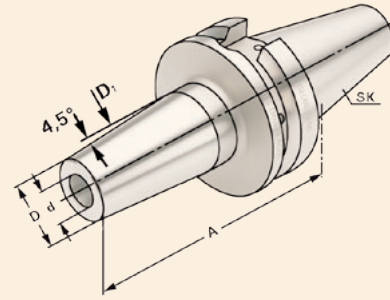

MAS 403 BT

JIS B 6339



$\nabla \leq 0,003$

G6,3
15.000 min⁻¹

Order no.	Taper	d	A	D	D ₁
BT.40ADB-SC.06.120	BT 40	6	120	21	27
BT.40ADB-SC.08.120	BT 40	8	120	21	27
BT.40ADB-SC.10.120	BT 40	10	120	24	32
BT.40ADB-SC.12.120	BT 40	12	120	24	32
BT.40ADB-SC.14.120	BT 40	14	120	27	34
BT.40ADB-SC.16.120	BT 40	16	120	27	34
BT.40ADB-SC.18.120	BT 40	18	120	33	42
BT.40ADB-SC.20.120	BT 40	20	120	33	42
BT.40ADB-SC.25.120	BT 40	25	120	44	53
BT.40ADB-SC.06.160	BT 40	6	160	21	27
BT.40ADB-SC.08.160	BT 40	8	160	21	27
BT.40ADB-SC.10.160	BT 40	10	160	24	32
BT.40ADB-SC.12.160	BT 40	12	160	24	32
BT.40ADB-SC.14.160	BT 40	14	160	27	34
BT.40ADB-SC.16.160	BT 40	16	160	27	34
BT.40ADB-SC.18.160	BT 40	18	160	33	42
BT.40ADB-SC.20.160	BT 40	20	160	33	42
BT.40ADB-SC.25.160	BT 40	25	160	44	53
BT.40ADB-SC.32.160	BT 40	32	160	44	62

Note: Toolholders suitable for induction-, contact- and hot air shrink units.
Ø 6 – Ø 32 with h6-tolerance



192 - 193

DIN 69871

ISO 60

MAS 403 BT

DIN 2080

HSK-A

VDI

MORSE



BT-SC

SHRINK FIT HOLDERS



Application:
For mounting straight-shank tools.

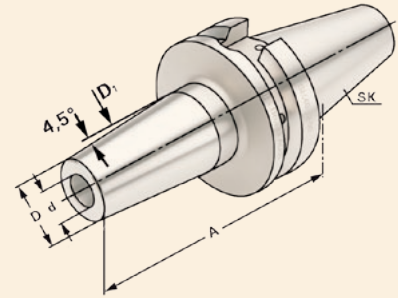

MAS 403 BT

JIS B 6339



$\nabla \leq 0,003$

G6,3
15.000 min⁻¹

Order no.	Taper	d	A	D	D ₁
BT.50ADB-SC.04.100	BT 50	4	100	14	22
BT.50ADB-SC.05.100	BT 50	5	100	16	22
BT.50ADB-SC.06.100	BT 50	6	100	21	27
BT.50ADB-SC.08.100	BT 50	8	100	21	27
BT.50ADB-SC.10.100	BT 50	10	100	24	32
BT.50ADB-SC.12.100	BT 50	12	100	24	32
BT.50ADB-SC.14.100	BT 50	14	100	27	34
BT.50ADB-SC.16.100	BT 50	16	100	27	34
BT.50ADB-SC.18.110	BT 50	18	110	33	42
BT.50ADB-SC.20.110	BT 50	20	110	33	42
BT.50ADB-SC.25.120	BT 50	25	120	44	53
BT.50ADB-SC.32.120	BT 50	32	120	44	53
BT.50ADB-SC.06.160	BT 50	6	160	21	27
BT.50ADB-SC.08.160	BT 50	8	160	21	27
BT.50ADB-SC.10.160	BT 50	10	160	24	32
BT.50ADB-SC.12.160	BT 50	12	160	24	32
BT.50ADB-SC.14.160	BT 50	14	160	27	34
BT.50ADB-SC.16.160	BT 50	16	160	27	34
BT.50ADB-SC.18.160	BT 50	18	160	33	42
BT.50ADB-SC.20.160	BT 50	20	160	33	42
BT.50ADB-SC.25.160	BT 50	25	160	44	53
BT.50ADB-SC.32.160	BT 50	32	160	44	53

For $\varnothing 3, 4$ and 5 mm only solid carbide tool shanks must be used!

Note: Toolholders suitable for induction-, contact- and hot air shrink units.
 $\varnothing 4, 5$ with h4-tolerance and $\varnothing 6 - \varnothing 32$ with h6-tolerance



192 - 193

DIN 69871

ISO 60

MAS 403 BT

DIN 2080

HSK-A

VDI

MORSE



BT-SC

SHRINK FIT HOLDERS



Application:
For mounting straight-shank tools.

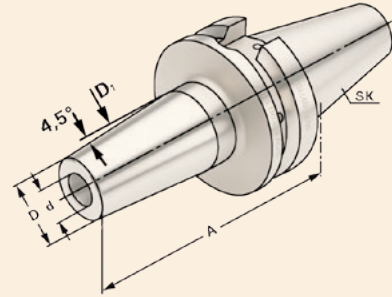

MAS 403 BT

JIS B 6339



$\nabla \leq 0,003$

G6,3
15.000 min⁻¹

Order no.	Taper	d	A	D	D ₁
BT.50ADB-SC.06.200	BT 50	6	200	21	27
BT.50ADB-SC.08.200	BT 50	8	200	21	27
BT.50ADB-SC.10.200	BT 50	10	200	24	32
BT.50ADB-SC.12.200	BT 50	12	200	24	32
BT.50ADB-SC.14.200	BT 50	14	200	27	34
BT.50ADB-SC.16.200	BT 50	16	200	27	34
BT.50ADB-SC.18.200	BT 50	18	200	33	42
BT.50ADB-SC.20.200	BT 50	20	200	33	42
BT.50ADB-SC.25.200	BT 50	25	200	44	53

Note: Toolholders suitable for induction-, contact- and hot air shrink units.
Ø 6 – Ø 32 with h6-tolerance



192 - 193

DIN 69871

ISO 60

MAS 403 BT

DIN 2080

HSK-A

VDI

MORSE



BT-SC-C

SHRINK FIT HOLDERS WITH COOLANT CHANNELS



Application:
For mounting straight-shank tools.

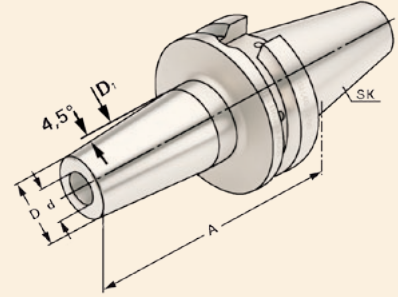

MAS 403 BT

JIS B 6339



$\nabla \leq 0,003$

G6,3
15.000 min⁻¹

Order no.	Taper	d	A	D	D ₁
BT.40ADB-SC.06.090.C	BT 40	6	90	21	27
BT.40ADB-SC.08.090.C	BT 40	8	90	21	27
BT.40ADB-SC.10.090.C	BT 40	10	90	24	32
BT.40ADB-SC.12.090.C	BT 40	12	90	24	32
BT.40ADB-SC.14.090.C	BT 40	14	90	27	34
BT.40ADB-SC.16.090.C	BT 40	16	90	27	34
BT.40ADB-SC.18.090.C	BT 40	18	90	33	42
BT.40ADB-SC.20.090.C	BT 40	20	90	33	42
BT.40ADB-SC.25.100.C	BT 40	25	100	44	53
BT.50ADB-SC.06.100.C	BT 50	6	100	21	27
BT.50ADB-SC.08.100.C	BT 50	8	100	21	27
BT.50ADB-SC.10.100.C	BT 50	10	100	24	32
BT.50ADB-SC.12.100.C	BT 50	12	100	24	32
BT.50ADB-SC.14.100.C	BT 50	14	100	27	34
BT.50ADB-SC.16.100.C	BT 50	16	100	27	34
BT.50ADB-SC.18.110.C	BT 50	18	110	33	42
BT.50ADB-SC.20.110.C	BT 50	20	110	33	42

Note: Toolholders suitable for induction-, contact- and hot air shrink units.
Ø 6 – Ø 32 with h6-tolerance



192 - 193

DIN 69871

ISO 60

MAS 403 BT

DIN 2080

HSK-A

VDI

MORSE



BT-IHA

HOLDERS FOR MILLING CUTTERS WITH THREADED END (EXCHANGEABLE HEAD)



Application:
For mounting screw-in cutters with thread.

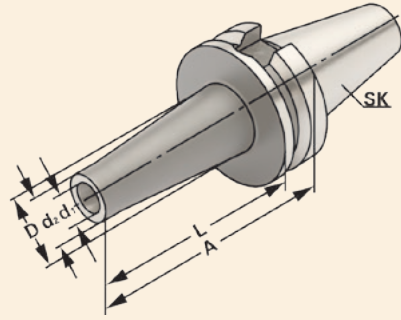

MAS 403 BT

JIS B 6339



$\nabla \leq 0,003$

G6,3
15.000 min⁻¹

Order no.	Taper	M	d1H4	d ₂	D	A	L
BT.40ADB-IHA.M6.025	BT 40	6	6,5	10	13	52	25
BT.40ADB-IHA.M6.050	BT 40	6	6,5	10	20	77	50
BT.40ADB-IHA.M6.075	BT 40	6	6,5	10	23	102	75
BT.40ADB-IHA.M8.025	BT 40	8	8,5	13	15	52	25
BT.40ADB-IHA.M8.050	BT 40	8	8,5	13	23	77	50
BT.40ADB-IHA.M8.075	BT 40	8	8,5	13	23	102	75
BT.40ADB-IHA.M8.100	BT 40	8	8,5	13	25	127	100
BT.40ADB-IHA.M10.025	BT 40	10	10,5	18	20	52	25
BT.40ADB-IHA.M10.050	BT 40	10	10,5	18	23	77	50
BT.40ADB-IHA.M10.075	BT 40	10	10,5	18	23	102	75
BT.40ADB-IHA.M10.100	BT 40	10	10,5	18	32	127	100
BT.40ADB-IHA.M12.025	BT 40	12	12,5	21	24	52	25
BT.40ADB-IHA.M12.050	BT 40	12	12,5	21	24	77	50
BT.40ADB-IHA.M12.075	BT 40	12	12,5	21	31	102	75
BT.40ADB-IHA.M12.100	BT 40	12	12,5	21	33	127	100
BT.40ADB-IHA.M12.125	BT 40	12	12,5	21	36	152	125
BT.40ADB-IHA.M16.025	BT 40	16	17	29	29	52	25
BT.40ADB-IHA.M16.050	BT 40	16	17	29	34	77	50
BT.40ADB-IHA.M16.075	BT 40	16	17	29	34	102	75
BT.40ADB-IHA.M16.100	BT 40	16	17	29	36	127	100
BT.40ADB-IHA.M16.125	BT 40	16	17	29	40	152	125
BT.40ADB-IHA.M16.150	BT 40	16	17	29	43	177	150
BT.50ADB-IHA.M8.050	BT 50	8	8,5	13	23	88	50
BT.50ADB-IHA.M8.100	BT 50	8	8,5	13	25	138	100
BT.50ADB-IHA.M8.150	BT 50	8	8,5	13	30	188	150
BT.50ADB-IHA.M10.050	BT 50	10	10,5	18	23	88	50
BT.50ADB-IHA.M10.100	BT 50	10	10,5	18	32	138	100
BT.50ADB-IHA.M10.150	BT 50	10	10,5	18	37	188	150
BT.50ADB-IHA.M12.050	BT 50	12	12,5	21	24	88	50
BT.50ADB-IHA.M12.100	BT 50	12	12,5	21	33	138	100
BT.50ADB-IHA.M12.150	BT 50	12	12,5	21	40	188	150
BT.50ADB-IHA.M16.050	BT 50	16	17	29	34	88	50
BT.50ADB-IHA.M16.075	BT 50	16	17	29	34	108	75
BT.50ADB-IHA.M16.100	BT 50	16	17	29	36	138	100
BT.50ADB-IHA.M16.150	BT 50	16	17	29	43	188	150



192 - 193

DIN 69871

ISO 60

MAS 403 BT

DIN 2080

HSK-A

VDI

MORSE



BT-BLANKS

BLANKS FOR SPECIAL HOLDERS



Application:
For the manufacturing of special tools.

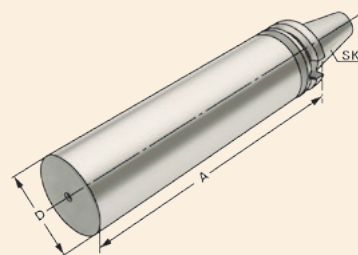

MAS 403 BT

JIS B 6339

Form
A

Order no.	Taper	D	A
BT.30A-BLA-40.160	BT 30	40,5	160
BT.40A-BLA-63.250	BT 40	63	250
BT.50A-BLA-97.315	BT 50	97	315

Version: **Cone and flange hardened and grinded. Soft body for later processing.**



DIN 69871

ISO 60

MAS 403 BT

DIN 2080

HSK-A

VDI

MORSE



BT-TA

TEST ARBORS



Application:

For the inspection of machine tools according to ISO recommendation R230 or for testing the tool spindle.

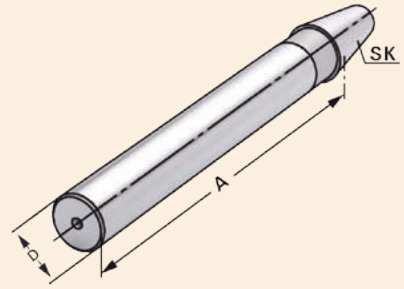

MAS 403 BT

JIS B 6339

Form
A

$\nabla \leq 0,003$

Order no. Taper Tolerance Max. concentricity deviation

BT.30A-TA-32.300	BT 30	300	32	0,003	0,003
BT.40A-TA-40.300	BT 40	300	40	0,003	0,003
BT.50A-TA-50.300	BT 50	300	50	0,003	0,003

Delivery: **Delivery with test certificate**

DIN 69871

ISO 60

MAS 403 BT

DIN 2080

HSK-A

VDI

MORSE



DIN 2080



Toolholders DIN 2080

DIN 69871

ISO 60

MAS 403 BT

DIN 2080

HSK-A

VDI

MORSE

Pre-balanced

G 6,3 15.000 min⁻¹

G 2.5 Fine balancing at extra charge

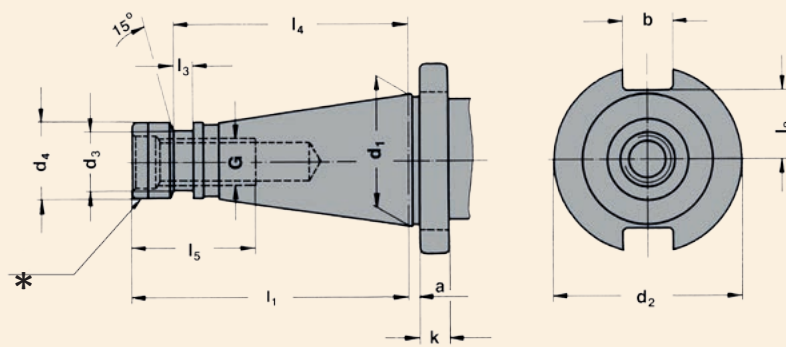

* With plastic protection ring

SK	d ₁	a	b	k	G	d ₂	d ₃	d ₄	l ₁	l ₂	l ₃	l ₄	l ₅
30	31,75	1,6	16,1	8	M12	50,0	—	17,2	68,4	16,2	—	—	24,0
40 *	44,45	1,6	16,1	10	M16	63,0	21,1	25,0	93,4	22,5	7,0	82,0	32,0
50 *	69,85	3,2	25,7	12	M24	97,5	32,0	39,2	126,8	35,3	13,0	115,0	47,0

Material: Alloyed case-hardened steel, tensile core strength of min. 1200 N / mm².
Case hardened HRC 60 ± 2 (HV 700 ± 50), hardening depth 0.8 mm ± 0.2 mm,
black-finished and precisely grinded.

Accuracy: Quality of taper < AT 3 according to DIN 7187 and DIN 2080.



2080-CC-OZ



82

2080-CC-ER



83

2080-W



84 - 85

2080-MT



86

2080-MTS



87

2080-RED-ISO



88

2080-FMH2



89

2080-FMH1



90

2080-DC



91

2080-QTCC



92

2080-BLANKS



93

DIN 69871

ISO 60

MAS 403 BT

DIN 2080

HSK-A

VDI

MORSE



2080-CC-OZ

COLLET CHUCKS - OZ



Application:
For mounting straight-shank tools in collets.

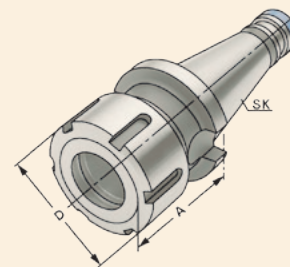

DIN 2080

$\nabla \leq 0,003$

G6,3
15.000 min⁻¹

Order no.	Taper	Range	A	D
2080.40-CC.OZ16.055	SK 40	2 – 16 (OZ 16)	55	43
2080.40-CC.OZ25.066	SK 40	2 – 25 (OZ 25)	66	60
2080.40-CC.OZ32.095	SK 40	3 – 32 (OZ 32)	95	72
2080.50-CC.OZ25.071	SK 50	2 – 25 (OZ 25)	71	60
2080.50-CC.OZ32.073	SK 50	3 – 32 (OZ 32)	73	72

Delivery: **With ball bearing clamping nut**



DIN 69871

ISO 60

MAS 403 BT

DIN 2080

HSK-A

VDI

MORSE



2080-CC-ER

COLLET CHUCKS - ER



Application:
For mounting straight-shank tools in collets.

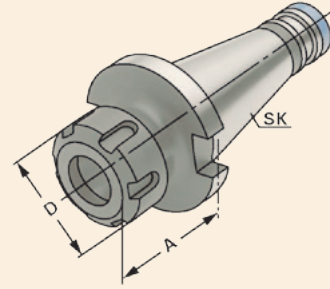

DIN 2080

$\nabla \leq 0,003$

G6,3
15.000 min⁻¹

Order no.	Taper	Range	A	D
2080.40-CC.ER25.050	SK 40	2 – 16 (ER 25)	50	42
2080.40-CC.ER32.050	SK 40	2 – 20 (ER 32)	50	50
2080.40-CC.ER40.080	SK 40	3 – 26 (ER 40)	80	63
2080.50-CC.ER32.063	SK 50	2 – 20 (ER 32)	63	50
2080.50-CC.ER40.063	SK 50	3 – 26 (ER 40)	63	63

Delivery: **With balanced clamping nut**



200 - 219



241



235



236



237 - 239

DIN 69871

ISO 60

MAS 403 BT

DIN 2080

HSK-A

VDI

MORSE



2080-W

WELDON END MILL HOLDERS



Application:

For mounting straight-shank tools with flat according to DIN 1835 form B (Weldon).

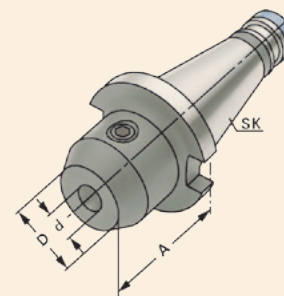

DIN 2080

$\nabla \leq 0,003$

G6,3
15.000 min⁻¹

Order no.	Taper	dH4	A	D
2080.40-W.06.050	SK 40	6	50	25
2080.40-W.08.050	SK 40	8	50	28
2080.40-W.10.050	SK 40	10	50	35
2080.40-W.12.050	SK 40	12	50	42
2080.40-W.14.050	SK 40	14	50	44
2080.40-W.16.063	SK 40	16	63	48
2080.40-W.18.063	SK 40	18	63	50
2080.40-W.20.063	SK 40	20	63	52
2080.40-W.25.080	SK 40	25	80	65
2080.40-W.32.080	SK 40	32	80	72
2080.40-W.40.090	SK 40	40	90	80

Note: From d = 25 on two clamping screws

Delivery: With clamping screw



DIN 69871

ISO 60

MAS 403 BT

DIN 2080

HSK-A

VDI

MORSE



2080-W

WELDON END MILL HOLDERS



Application:

For mounting straight-shank tools with flat according to DIN 1835 form B (Weldon).

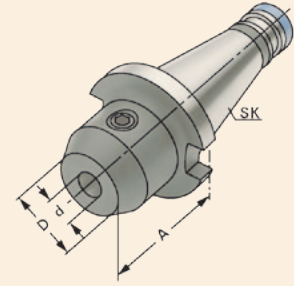

DIN 2080

$\nabla \leq 0,003$

G6,3
15.000 min⁻¹

Order no.	Taper	dH4	A	D
2080.50-W.06.063	SK 50	6	63	25
2080.50-W.08.063	SK 50	8	63	28
2080.50-W.10.063	SK 50	10	63	35
2080.50-W.12.063	SK 50	12	63	42
2080.50-W.14.063	SK 50	14	63	44
2080.50-W.16.063	SK 50	16	63	48
2080.50-W.18.063	SK 50	18	63	50
2080.50-W.20.063	SK 50	20	63	52
2080.50-W.25.080	SK 50	25	80	65
2080.50-W.32.080	SK 50	32	80	72
2080.50-W.40.090	SK 50	40	90	80

Note: From d = 25 on two clamping screws

Delivery: With clamping screw



DIN 69871

ISO 60

MAS 403 BT

DIN 2080

HSK-A

VDI

MORSE



2080-MT

HOLDERS FOR MORSE TAPER



Application:

For mounting tools with Morse taper shank and tang according to DIN 228-1 form B.

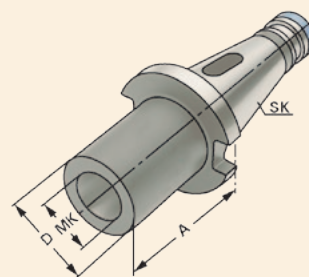

DIN 2080

$\nabla \leq 0,005$

G6,3
15.000 min⁻¹

Order no.	Taper	MK	A	D
2080.40-MT.1.050	SK 40	1	50	25
2080.40-MT.2.050	SK 40	2	50	32
2080.40-MT.3.065	SK 40	3	65	40
2080.40-MT.4.095	SK 40	4	95	48
2080.50-MT.1.045	SK 50	1	45	25
2080.50-MT.2.060	SK 50	2	60	32
2080.50-MT.3.065	SK 50	3	65	40
2080.50-MT.4.070	SK 50	4	70	48
2080.50-MT.5.105	SK 50	5	105	63
2080.50-MT.6.250	SK 50	6	250	90
2080.50-MT.6.295	SK 50	6	295	97



242

DIN 69871

ISO 60

MAS 403 BT

DIN 2080

HSK-A

VDI

MORSE



2080-MTS

HOLDERS FOR MORSE TAPER WITH DRAWBAR THREAD



Application:

For clamping tools with Morse taper shank and thread according to DIN 228-1 form A.

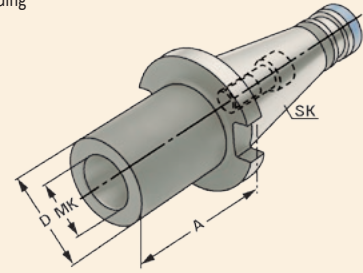

DIN 2080

$\nabla \leq 0,005$

G6,3
15.000 min⁻¹

Order no.	Taper	MK	M	A	D
2080.40-MTS.1.050	SK 40	1	M6	50	25
2080.40-MTS.2.050	SK 40	2	M10	50	32
2080.40-MTS.3.065	SK 40	3	M12	65	40
2080.40-MTS.4.095	SK 40	4	M16	95	48
2080.50-MTS.1.060	SK 50	1	M6	60	25
2080.50-MTS.2.060	SK 50	2	M10	60	32
2080.50-MTS.3.065	SK 50	3	M12	65	40
2080.50-MTS.4.065	SK 50	4	M16	65	48
2080.50-MTS.5.120	SK 50	5	M20	120	63

Delivery: With built-in tightening bolt

DIN 69871

ISO 60

MAS 403 BT

DIN 2080

HSK-A

VDI

MORSE



2080-RED-ISO

REDUCTIONS FOR ISO CONE



Application:
For holding tapers according to DIN 69871,
JIS B 6339 and DIN 2080.

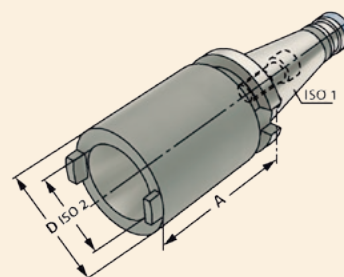

DIN 2080

$\nabla \leq 0,005$

G6,3
15.000 min⁻¹

Order no.	ISO 1	ISO 2	A	D
2080.40-RED.ISO30.50	SK 40	ISO 30	50	50
2080.40-RED.ISO40.100	SK 40	ISO 40	100	63
2080.50-RED.ISO40.050	SK 50	ISO 40	50	70
2080.50-RED.ISO50.125	SK 50	ISO 50	125	97

Note: Delivered with a built-in screw for DIN 2080 tools. Additional screw for DIN 69871 tools included.

DIN 69871

ISO 60

MAS 403 BT

DIN 2080

HSK-A

VDI

MORSE



2080-FMH2

COMBI SHELL MILL HOLDERS



Application:
For mounting milling cutters with transverse or longitudinal groove.

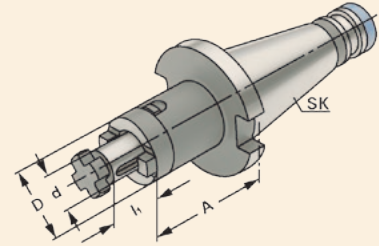

DIN 2080

$\nabla \leq 0,005$

G6,3
15.000 min⁻¹

Order no.	Taper	dh6	A	l ₁	D
2080.40-FMH2.16.052	SK 40	16	52	17	32
2080.40-FMH2.22.052	SK 40	22	52	19	40
2080.40-FMH2.27.052	SK 40	27	52	21	48
2080.40-FMH2.32.052	SK 40	32	52	24	58
2080.40-FMH2.40.052	SK 40	40	52	27	70
2080.50-FMH2.16.055	SK 50	16	55	17	32
2080.50-FMH2.22.055	SK 50	22	55	19	40
2080.50-FMH2.27.055	SK 50	27	55	21	48
2080.50-FMH2.32.055	SK 50	32	55	24	58
2080.50-FMH2.40.055	SK 50	40	55	27	70

Delivery: With tightening bolt, driving ring and feather key



DIN 69871

ISO 60

MAS 403 BT

DIN 2080

HSK-A

VDI

MORSE



2080-FMH1

SHELL MILL HOLDERS



Application:
For mounting milling cutters with transversal groove.

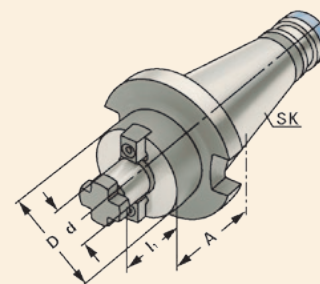

DIN 2080

$\nabla \leq 0,005$

G6,3
15.000 min⁻¹

Order no.	Taper	dh6	l1	A	D
2080.40-FMH1.16.030	SK 40	16	17	30	38
2080.40-FMH1.22.030	SK 40	22	19	30	48
2080.40-FMH1.27.030	SK 40	27	21	30	58
2080.40-FMH1.32.030	SK 40	32	24	30	78
2080.40-FMH1.40.030	SK 40	40	27	30	88
2080.50-FMH1.22.035	SK 50	22	19	35	48
2080.50-FMH1.27.035	SK 50	27	21	35	58
2080.50-FMH1.32.040	SK 50	32	24	40	78
2080.50-FMH1.40.033	SK 50	40	27	33	88
2080.50-FMH1.60.055	SK 50	60	40	55	129

d = 40/d = 60: For large diameter face mill cutters with four additional threaded holes according to DIN 2079.

Delivery: With drivers, cross head retaining screw and cylinder head retaining screw DIN 912.
For d = 60 only with four fixation screws according to DIN 912.



DIN 69871

ISO 60

MAS 403 BT

DIN 2080

HSK-A

VDI

MORSE



2080-DC

DRILL CHUCK HOLDERS



Application:
For mounting tools with straight shanks.

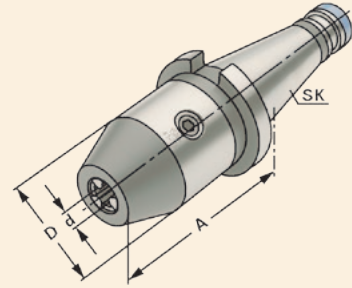

DIN 2080

$\nabla \leq 0,03$

G6,3
15.000 min⁻¹

Order no.	Taper	d Range	A	D
2080.40-DC.08.063	SK 40	0,5 – 8	63	36
2080.40-DC.13.083	SK 40	1 – 13	83	50
2080.40-DC.16.088	SK 40	2,5 – 16	88	50
2080.50-DC.13.085	SK 50	1 – 13	85	50
2080.50-DC.16.090	SK 50	2,5 – 16	90	50

Note: High precision and accurate concentricity of ≤ 0.03 mm. Secure gripping of the tool through mechanical amplification of the clamping force. No automatic slackening of the clamping force while machining with either clockwise or counter clockwise rotation or on spindle stop. Clamping and releasing effected by means of an Allen wrench.

Delivery: With wrench

DIN 69871

ISO 60

MAS 403 BT

DIN 2080

HSK-A

VDI

MORSE



2080-QTCC

QUICK-CHANGE TAPPING CHUCKS WITH COMPENSATION



Application:
For the chucking of quick change adaptors for taps.

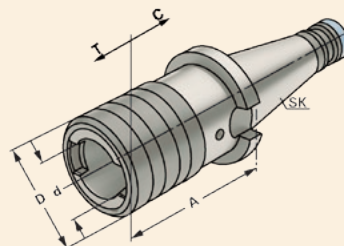

DIN 2080

Order no.	Taper	Range	Size					
2080.40-QTCC.M3.M14	SK 40	M3 – M14	1	55	38	19	7	7
2080.40-QTCC.M5.M22	SK 40	M5 – M22	2	86	54	31	12	12
2080.40-QTCC.M14.M36	SK 40	M14 – M36	3	132	78	48	17,5	17,5
2080.50-QTCC.M3.M14	SK 50	M3 – M14	1	62	38	19	7	7
2080.50-QTCC.M5.M22	SK 50	M5 – M22	2	90	54	31	12	12
2080.50-QTCC.M14.M36	SK 50	M14 – M36	3	117	78	48	17,5	17,5



DIN 69871

ISO 60

MAS 403 BT

DIN 2080

HSK-A

VDI

MORSE



2080-BLANKS

BLANKS FOR SPECIAL HOLDERS



Application:
For the manufacturing of special tools.

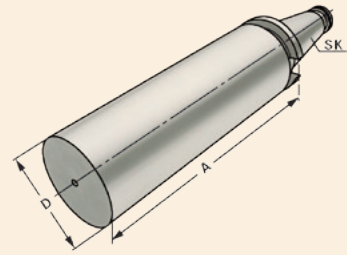

DIN 2080

Order no.	Taper	A	D
2080.40-BLA.63.250	SK 40	250	63
2080.50-BLA.97.315	SK 50	315	97

Version: **Cone and flange hardened and grinded. Soft body for later processing.**

DIN 69871

ISO 60

MAS 403 BT

DIN 2080

HSK-A

VDI

MORSE



HSK-A

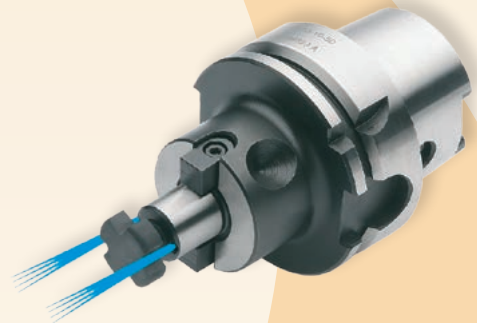

HSK toolholders DIN 69893 (ISO 12164-1) Form A

DIN 69871

ISO 60

MAS 403 BT

DIN 2080

HSK-A

VDI

MORSE

Pre-balanced

G 6,3 15.000 min⁻¹

G 2.5 Fine balancing at extra charge

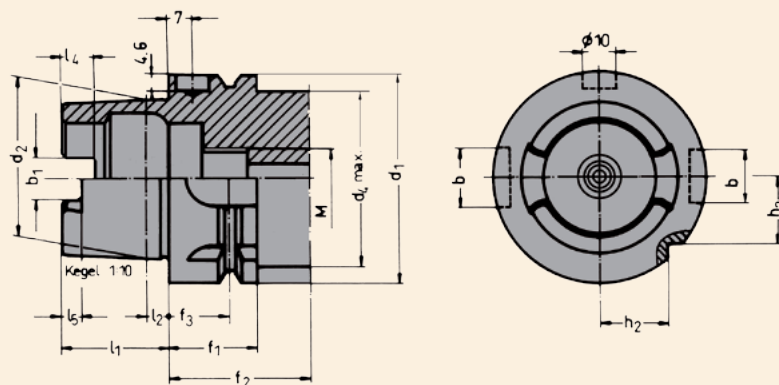

d ₁	d ₂	d ₄	l ₁	l ₂	l ₄	l ₅	M	f ₁	f ₂	f ₃	b ₁	b ₂	b ₃
63	48	53	32	6,3	10,0	6,0	M18 × 1	26	42	18	12,54	16	18
100	75	85	50	10,0	15,0	10,0	M24 × 1,5	29	45	20	20,02	22	20

Material: Alloyed case-hardened steel, tensile core strength of min. 1200 N / mm².
Case hardened HRC 60 ± 2 (HV 700 ± 50), hardening depth 0.8 mm ± 0.2 mm,
black-finished and precisely grinded.



HSK-A-CC-OZ



▣ 98

HSK-A-CC-ER



▣ 99

HSK-A-CCM-ER



▣ 100

HSK-A-CC-HKS



▣ 101

HSK-A-W



▣ 102 - 103

HSK-A-W-C



▣ 104

HSK-A-FMH2



▣ 105

HSK-A-FMH1



▣ 106 - 107

HSK-A-FMH4



▣ 108

HSK-A-MT



▣ 109

HSK-A-MTS



▣ 110

HSK-A-QTCC



▣ 111

HSK-A-QTCW



▣ 112

HSK-A-DC



▣ 113

HSK-A-HC



▣ 114 - 116

HSK-A-SC



▣ 117 - 120

HSK-A-SC-C



▣ 121 - 122

HSK-A-IHA



▣ 123

HSK-A-BLANKS



▣ 124

HSK-A-TA



▣ 125

DIN 69871

ISO 60

MAS 403 BT

DIN 2080

HSK-A

VDI

MORSE



HSK-A-CC-OZ

COLLET CHUCKS - OZ



Application:
For mounting straight-shank tools in collets.

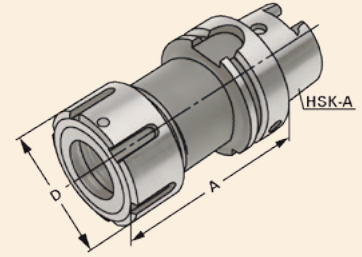

ISO 12164-1

DIN 69893-1

HSK-A

$\nabla \leq 0,003$

G6,3
15.000 min⁻¹

Order no.	Taper	Range	A	D
HSK.63A-CC.OZ16.100	HSK-A 63	2 – 16 (OZ 16)	100	43
HSK.63A-CC.OZ25.100	HSK-A 63	2 – 25 (OZ 25)	100	60
HSK.63A-CC.OZ32.120	HSK-A 63	3 – 32 (OZ 32)	120	72
HSK.100A-CC.OZ16.110	HSK-A 100	2 – 16 (OZ 16)	110	43
HSK.100A-CC.OZ25.120	HSK-A 100	2 – 25 (OZ 25)	120	60
HSK.100A-CC.OZ32.130	HSK-A 100	3 – 32 (OZ 32)	130	72

Delivery: **With ball bearing clamping nut**



DIN 69871

ISO 60

MAS 403 BT

DIN 2080

HSK-A

VDI

MORSE



HSK-A-CC-ER

COLLET CHUCKS - ER



Application:
For mounting straight-shank tools in collets.

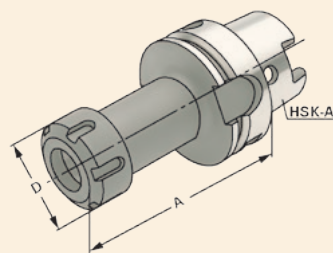

ISO 12164-1

DIN 69893-1

HSK-A

$\nabla \leq 0,003$

G6,3
15.000 min⁻¹

Order no.	Taper	Range	A	D
HSK.63A-CC.ER16.075	HSK-A 63	1 – 10 (ER 16)	75	32
HSK.63A-CC.ER25.075	HSK-A 63	2 – 16 (ER 25)	75	42
HSK.63A-CC.ER32.075	HSK-A 63	2 – 20 (ER 32)	75	50
HSK.63A-CC.ER40.085	HSK-A 63	3 – 26 (ER 40)	85	63
HSK.63A-CC.ER16.100	HSK-A 63	1 – 10 (ER 16)	100	32
HSK.63A-CC.ER25.100	HSK-A 63	2 – 16 (ER 25)	100	42
HSK.63A-CC.ER32.100	HSK-A 63	2 – 20 (ER 32)	100	50
HSK.63A-CC.ER40.120	HSK-A 63	3 – 26 (ER 40)	120	63
HSK.63A-CC.ER16.160	HSK-A 63	1 – 10 (ER 16)	160	32
HSK.63A-CC.ER25.160	HSK-A 63	2 – 16 (ER 25)	160	42
HSK.63A-CC.ER32.160	HSK-A 63	2 – 20 (ER 32)	160	50
HSK.63A-CC.ER40.160	HSK-A 63	3 – 26 (ER 40)	160	63
HSK.63A-CC.ER16.200	HSK-A 63	1 – 10 (ER 16)	200	32
HSK.63A-CC.ER25.200	HSK-A 63	2 – 16 (ER 25)	200	42
HSK.63A-CC.ER32.200	HSK-A 63	2 – 20 (ER 32)	200	50
HSK.63A-CC.ER40.200	HSK-A 63	3 – 26 (ER 40)	200	63
HSK.100A-CC.ER25.100	HSK-A 100	2 – 16 (ER 25)	100	42
HSK.100A-CC.ER32.100	HSK-A 100	2 – 20 (ER 32)	100	50
HSK.100A-CC.ER40.120	HSK-A 100	3 – 26 (ER 40)	120	63
HSK.100A-CC.ER25.160	HSK-A 100	2 – 16 (ER 25)	160	42
HSK.100A-CC.ER32.160	HSK-A 100	2 – 20 (ER 32)	160	50
HSK.100A-CC.ER40.160	HSK-A 100	3 – 26 (ER 40)	160	63

Delivery: With balanced clamping nut



200 - 219

241

235

236

237 - 239

248

248

DIN 69871

ISO 60

MAS 403 BT

DIN 2080

HSK-A

VDI

MORSE



HSK-A-CCM-ER

MINI COLLET CHUCKS - ER



Application:
For mounting straight-shank tools in collets.

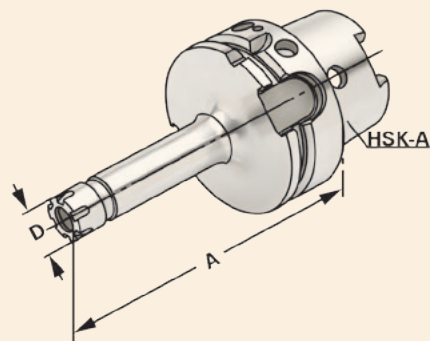

ISO 12164-1

DIN 69893-1

HSK-A

$\nabla \leq 0,003$

G6,3
15.000 min⁻¹

Order no.	Taper	Range	A	D
HSK.63A-CCM.ER11.100	HSK-A 63	1 – 7 (ER 11)	100	16
HSK.63A-CCM.ER11.160	HSK-A 63	1 – 7 (ER 11)	160	16
HSK.63A-CCM.ER16.100	HSK-A 63	1 – 10 (ER 16)	100	22
HSK.63A-CCM.ER16.160	HSK-A 63	1 – 10 (ER 16)	160	22

DIN 69871

ISO 60

MAS 403 BT

DIN 2080

HSK-A

VDI

MORSE



HSK-A-CC-HKS

HIGH PERFORMANCE CHUCKS - HKS



Application:

For mounting straight-shank tools acc. DIN 1835 form A+B+E and DIN 6535 form HA+HB+HE (smaller than dia. 20 mm or 32 mm only with reduction sleeve).

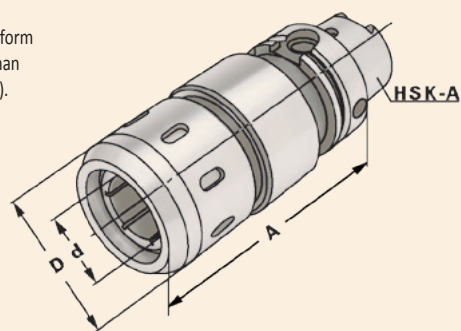

ISO 12164-1

DIN 69893-1

HSK-A

$\nabla \leq 0,003$

G6,3
15.000 min⁻¹

Order no.	Taper	Range	A	D
HSK.63A-CC.HKS20.095	HSK-A 63	3-20 (HKS 20)	95	53
HSK.63A-CC.HKS32.110	HSK-A 63	3-32 (HKS 32)	110	68
HSK.100A-CC.HKS20.105	HSK-A 100	3-20 (HKS 20)	105	53
HSK.100A-CC.HKS32.105	HSK-A 100	3-32 (HKS 32)	105	68



DIN 69871

ISO 60

MAS 403 BT

DIN 2080

HSK-A

VDI

MORSE



HSK-A-W

WELDON END MILL HOLDERS



Application:

For mounting straight-shank tools with flat according to DIN 1835 form B (Weldon).

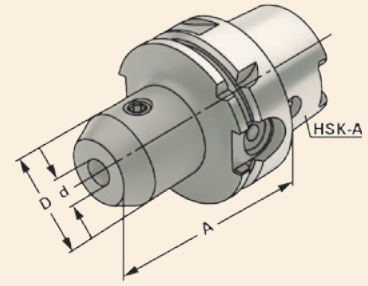

ISO 12164-1

DIN 69893-1

HSK-A

$\nabla \leq 0,003$

G6,3
15.000 min⁻¹

Order no.	Taper	dH4	A	D
HSK.63A-W.06.065	HSK-A 63	6	65	25
HSK.63A-W.08.065	HSK-A 63	8	65	28
HSK.63A-W.10.065	HSK-A 63	10	65	35
HSK.63A-W.12.080	HSK-A 63	12	80	42
HSK.63A-W.14.080	HSK-A 63	14	80	44
HSK.63A-W.16.080	HSK-A 63	16	80	48
HSK.63A-W.18.080	HSK-A 63	18	80	50
HSK.63A-W.20.080	HSK-A 63	20	80	52
HSK.63A-W.25.110	HSK-A 63	25	110	65
HSK.63A-W.32.110	HSK-A 63	32	110	72
HSK.63A-W.40.125	HSK-A 63	40	125	80
HSK.63A-W.06.100	HSK-A 63	6	100	25
HSK.63A-W.08.100	HSK-A 63	8	100	28
HSK.63A-W.10.100	HSK-A 63	10	100	35
HSK.63A-W.12.100	HSK-A 63	12	100	35
HSK.63A-W.14.100	HSK-A 63	14	100	44
HSK.63A-W.16.100	HSK-A 63	16	100	48
HSK.63A-W.18.100	HSK-A 63	18	100	50
HSK.63A-W.20.100	HSK-A 63	20	100	52
HSK.63A-W.06.160	HSK-A 63	6	160	25
HSK.63A-W.08.160	HSK-A 63	8	160	28
HSK.63A-W.10.160	HSK-A 63	10	160	35
HSK.63A-W.12.160	HSK-A 63	12	160	35
HSK.63A-W.14.160	HSK-A 63	14	160	44
HSK.63A-W.16.160	HSK-A 63	16	160	48
HSK.63A-W.18.160	HSK-A 63	18	160	50
HSK.63A-W.20.160	HSK-A 63	20	160	52

Note: From d = 25 on two clamping screws



Delivery: With clamping screw



HSK-A-W

WELDON END MILL HOLDERS



Application:
For mounting straight-shank tools with flat according to DIN 1835 form B (Weldon).

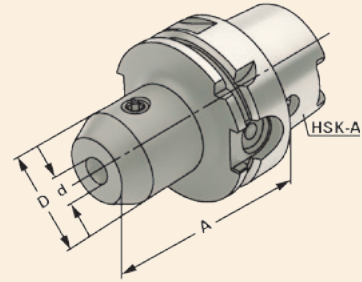

ISO 12164-1

DIN 69893-1

HSK-A

$\nabla \leq 0,003$

G6,3
15.000 min⁻¹

Order no.	Taper	dH4	A	D
HSK.100A-W.06.080	HSK-A 100	6	80	25
HSK.100A-W.08.080	HSK-A 100	8	80	28
HSK.100A-W.10.080	HSK-A 100	10	80	35
HSK.100A-W.12.080	HSK-A 100	12	80	42
HSK.100A-W.14.080	HSK-A 100	14	80	44
HSK.100A-W.16.100	HSK-A 100	16	100	48
HSK.100A-W.18.100	HSK-A 100	18	100	50
HSK.100A-W.20.100	HSK-A 100	20	100	52
HSK.100A-W.25.100	HSK-A 100	25	100	65
HSK.100A-W.32.100	HSK-A 100	32	100	72
HSK.100A-W.40.105	HSK-A 100	40	105	80
HSK.100A-W.06.160	HSK-A 100	6	160	25
HSK.100A-W.08.160	HSK-A 100	8	160	28
HSK.100A-W.10.160	HSK-A 100	10	160	35
HSK.100A-W.12.160	HSK-A 100	12	160	42
HSK.100A-W.14.160	HSK-A 100	14	160	44
HSK.100A-W.16.160	HSK-A 100	16	160	48
HSK.100A-W.18.160	HSK-A 100	18	160	50
HSK.100A-W.20.160	HSK-A 100	20	160	52
HSK.100A-W.25.160	HSK-A 100	25	160	65
HSK.100A-W.32.160	HSK-A 100	32	160	72
HSK.100A-W.40.160	HSK-A 100	40	160	80

Note: From d = 25 on two clamping screws

Delivery: With clamping screw



DIN 69871

ISO 60

MAS 403 BT

DIN 2080

HSK-A

VDI

MORSE



HSK-A-W-C

WELDON END MILL HOLDERS WITH COOLANT CHANNELS



Application:

For mounting straight-shank tools with flat according to DIN 1835 form B (Weldon). With coolant channels for optimal coolant at the cutting edge.

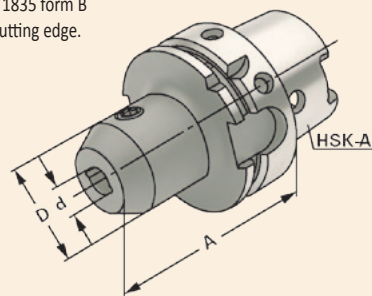

ISO 12164-1

DIN 69893-1

HSK-A

$\nabla \leq 0,003$

G6,3
15.000 min⁻¹

Order no.	Taper	dH4	A	D
HSK.63A-W.06.065.C	HSK-A 63	6	65	25
HSK.63A-W.08.065.C	HSK-A 63	8	65	28
HSK.63A-W.10.065.C	HSK-A 63	10	65	35
HSK.63A-W.12.080.C	HSK-A 63	12	80	42
HSK.63A-W.14.080.C	HSK-A 63	14	80	44
HSK.63A-W.16.080.C	HSK-A 63	16	80	48
HSK.63A-W.18.080.C	HSK-A 63	18	80	50
HSK.63A-W.20.080.C	HSK-A 63	20	80	52
HSK.63A-W.25.110.C	HSK-A 63	25	110	65
HSK.63A-W.32.110.C	HSK-A 63	32	110	72
HSK.63A-W.40.125.C	HSK-A 63	40	125	80
HSK.63A-W.06.100.C	HSK-A 63	6	100	25
HSK.63A-W.08.100.C	HSK-A 63	8	100	28
HSK.63A-W.10.100.C	HSK-A 63	10	100	35
HSK.63A-W.12.100.C	HSK-A 63	12	100	42
HSK.63A-W.14.100.C	HSK-A 63	14	100	44
HSK.63A-W.16.100.C	HSK-A 63	16	100	48
HSK.63A-W.18.100.C	HSK-A 63	18	100	50
HSK.63A-W.20.100.C	HSK-A 63	20	100	52
HSK.100A-W.06.080.C	HSK-A 100	6	80	25
HSK.100A-W.08.080.C	HSK-A 100	8	80	28
HSK.100A-W.10.080.C	HSK-A 100	10	80	35
HSK.100A-W.12.080.C	HSK-A 100	12	80	42
HSK.100A-W.14.080.C	HSK-A 100	14	80	44
HSK.100A-W.16.100.C	HSK-A 100	16	100	48
HSK.100A-W.18.100.C	HSK-A 100	18	100	50
HSK.100A-W.20.100.C	HSK-A 100	20	100	52
HSK.100A-W.25.100.C	HSK-A 100	25	100	65
HSK.100A-W.32.100.C	HSK-A 100	32	100	72
HSK.100A-W.40.105.C	HSK-A 100	40	105	80

Note:

From d = 25 on two clamping screws, d = 6 to 14 with two coolant channels, d = 16 to 40 with four coolant channels. For tools with through coolant an O-ring must be used.



245

248

HSK-A-FMH2

COMBI SHELL MILL HOLDERS



Application:

For mounting milling cutters with transverse or longitudinal groove.

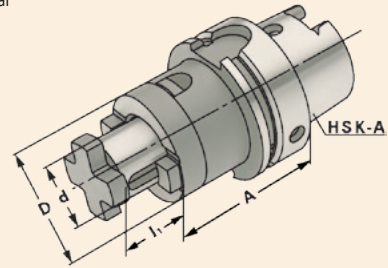

ISO 12164-1

DIN 69893-1

HSK-A

$\sqrt{\text{R}} \leq 0,003$

G6,3
15.000 min⁻¹

Order no.	Taper	dh6	A	l ₁	D
HSK.63A-FMH2.16.060	HSK-A 63	16	60	17	32
HSK.63A-FMH2.22.060	HSK-A 63	22	60	19	40
HSK.63A-FMH2.27.060	HSK-A 63	27	60	21	48
HSK.63A-FMH2.32.060	HSK-A 63	32	60	24	58
HSK.63A-FMH2.40.070	HSK-A 63	40	70	27	70
HSK.63A-FMH2.16.100	HSK-A 63	16	100	17	32
HSK.63A-FMH2.22.100	HSK-A 63	22	100	19	40
HSK.63A-FMH2.27.100	HSK-A 63	27	100	21	48
HSK.63A-FMH2.32.100	HSK-A 63	32	100	24	58
HSK.100A-FMH2.16.060	HSK-A 100	16	60	17	32
HSK.100A-FMH2.22.060	HSK-A 100	22	60	19	40
HSK.100A-FMH2.27.060	HSK-A 100	27	60	21	48
HSK.100A-FMH2.32.060	HSK-A 100	32	60	24	58
HSK.100A-FMH2.40.070	HSK-A 100	40	70	27	70

Delivery: With tightening bolt, driving ring and feather key



DIN 69871

ISO 60

MAS 403 BT

DIN 2080

HSK-A

VDI

MORSE



HSK-A-FMH1

SHELL MILL HOLDERS



Application:
For mounting milling cutters with transversal groove.

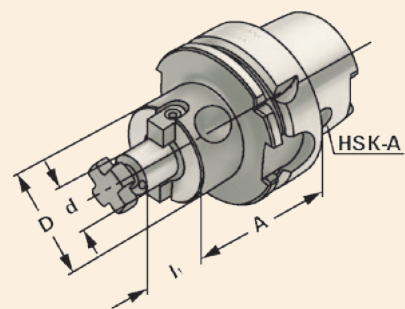

ISO 12164-1

DIN 69893-1

HSK-A

$\nabla \leq 0,003$

G6,3
15.000 min⁻¹

Order no.	Taper	dh6	A	l ₁	D
HSK.63A-FMH1.16.050	HSK-A 63	16	50	17	38
HSK.63A-FMH1.22.050	HSK-A 63	22	50	19	48
HSK.63A-FMH1.27.060	HSK-A 63	27	60	21	58
HSK.63A-FMH1.32.060	HSK-A 63	32	60	24	78
HSK.63A-FMH1.40.060	HSK-A 63	40	60	27	88
HSK.63A-FMH1.16.100	HSK-A 63	16	100	17	38
HSK.63A-FMH1.22.100	HSK-A 63	22	100	19	48
HSK.63A-FMH1.27.100	HSK-A 63	27	100	21	58
HSK.63A-FMH1.32.100	HSK-A 63	32	100	24	78
HSK.63A-FMH1.40.100	HSK-A 63	40	100	27	88
HSK.63A-FMH1.16.160	HSK-A 63	16	160	17	38
HSK.63A-FMH1.22.160	HSK-A 63	22	160	19	48
HSK.63A-FMH1.27.160	HSK-A 63	27	160	21	58
HSK.63A-FMH1.32.160	HSK-A 63	32	160	24	78
HSK.63A-FMH1.40.160	HSK-A 63	40	160	27	88

d = 40: For large diameter face mill cutters with four additional threaded holes according to DIN 2079.

Delivery: With drivers, cross head retaining screw and cylinder head retaining screw for cutters with central coolant.



HSK-A-FMH1

SHELL MILL HOLDERS



Application:
For mounting milling cutters with transversal groove.

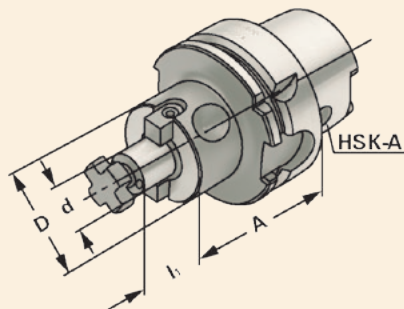

- ISO 12164-1
- DIN 69893-1
- HSK-A
- $\nabla \leq 0,003$
- G6,3
15.000 min⁻¹

Order no.	Taper	dh6	A	l ₁	D
HSK.100A-FMH1.22.050	HSK-A 100	22	50	19	48
HSK.100A-FMH1.27.050	HSK-A 100	27	50	21	58
HSK.100A-FMH1.32.060	HSK-A 100	32	60	24	78
HSK.100A-FMH1.40.070	HSK-A 100	40	70	27	88
HSK.100A-FMH1.60.070	HSK-A 100	60	70	40	130
HSK.100A-FMH1.22.100	HSK-A 100	22	100	19	48
HSK.100A-FMH1.27.100	HSK-A 100	27	100	21	58
HSK.100A-FMH1.32.100	HSK-A 100	32	100	24	78
HSK.100A-FMH1.40.100	HSK-A 100	40	100	27	88

d = 40/d = 60: For large diameter face mill cutters with four additional threaded holes according to DIN 2079.

Delivery: With drivers, cross head retaining screw and cylinder head retaining screw for cutters with central coolant.
For d = 60 only with four fixation screws according to DIN 912.



-  242
-  243 - 244
-  248
-  248

DIN 69871

ISO 60

MAS 403 BT

DIN 2080

HSK-A

VDI

MORSE



HSK-A-FMH4

HOLDERS FOR DISC MILLING CUTTERS



Application:
For mounting disc milling cutters.

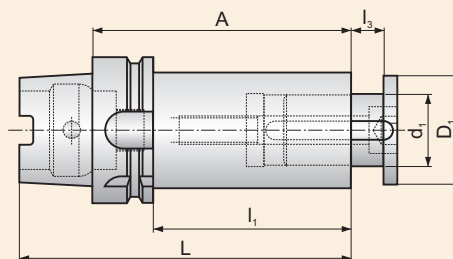

ISO 12164-1 DIN 69893-1 HSK-A $\nabla \leq 0,003$ G6,3 15.000 min⁻¹

Référence	Taper	dh6	A	L	l ₁	l ₃	D ₁
HSK.63A-FMH4.27.120	HSK-A 63	27	120	152	94	0-15	42
HSK.63A-FMH4.32.150	HSK-A 63	32	150	182	124	0-24	48
HSK.100A-FMH4.27.120	HSK-A 100	27	120	170	91	0-15	42
HSK.100A-FMH4.32.155	HSK-A 100	32	155	205	126	0-24	48
HSK.100A-FMH4.40.190	HSK-A 100	40	190	240	161	0-30	58
HSK.100A-FMH4.50.235	HSK-A 100	50	235	285	206	0-32	72
HSK.100A-FMH4.60.255	HSK-A 100	60	255	305	226	0-40	90

Delivery: With drive shafts, screws and hexagonal key.



247

247

248

248

DIN 69871

ISO 60

MAS 403 BT

DIN 2080

HSK-A

VDI

MORSE

HSK-A-MT

HOLDERS FOR MORSE TAPER



Application:
For mounting tools with Morse taper shank and tang according to DIN 228-1 form B.

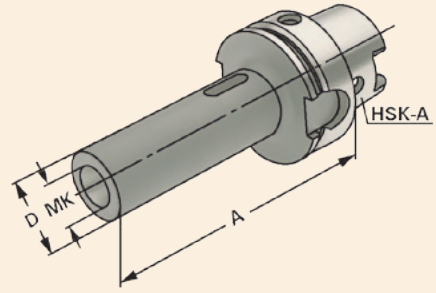

ISO 12164-1

DIN 69893-1

HSK-A

$\nabla \leq 0,003$

G6,3
15.000 min⁻¹

Order no.	Taper	MK	A	D
HSK.63A-MT.1.100	HSK-A 63	1	100	25
HSK.63A-MT.2.120	HSK-A 63	2	120	32
HSK.63A-MT.3.140	HSK-A 63	3	140	40
HSK.63A-MT.4.160	HSK-A 63	4	160	48
HSK.100A-MT.1.110	HSK-A 100	1	110	25
HSK.100A-MT.2.120	HSK-A 100	2	120	32
HSK.100A-MT.3.150	HSK-A 100	3	150	40
HSK.100A-MT.4.170	HSK-A 100	4	170	48
HSK.100A-MT.5.200	HSK-A 100	5	200	63



DIN 69871

ISO 60

MAS 403 BT

DIN 2080

HSK-A

VDI

MORSE



HSK-A-MTS

HOLDERS FOR MORSE TAPER WITH DRAWBAR THREAD



Application:
For clamping tools with Morse taper shank and thread according to DIN 228-1 form A.

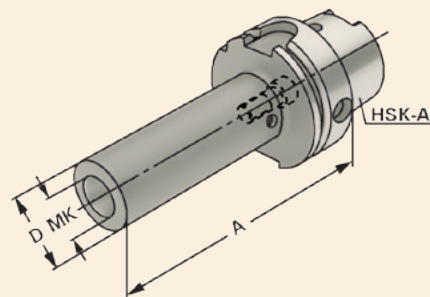

ISO 12164-1

DIN 69893-1

HSK-A

$\nabla \leq 0,003$

G6,3
15.000 min⁻¹

Order no.	Taper	MK	M	A	D
HSK.63A-MTS.1.100	HSK-A 63	1	M6	100	25
HSK.63A-MTS.2.120	HSK-A 63	2	M10	120	32
HSK.63A-MTS.3.140	HSK-A 63	3	M12	140	40
HSK.63A-MTS.4.160	HSK-A 63	4	M16	160	48
HSK.100A-MTS.1.110	HSK-A 100	1	M6	110	25
HSK.100A-MTS.2.120	HSK-A 100	2	M10	120	32
HSK.100A-MTS.3.150	HSK-A 100	3	M12	150	40
HSK.100A-MTS.4.170	HSK-A 100	4	M16	170	48
HSK.100A-MTS.5.200	HSK-A 100	5	M20	200	63

Delivery: **With built-in tightening bolt**



248

248

DIN 69871

ISO 60

MAS 403 BT

DIN 2080

HSK-A

VDI

MORSE



HSK-A-QTCC

QUICK-CHANGE TAPPING CHUCKS WITH COMPENSATION



Application:
For the chucking of quick change adaptors for taps.

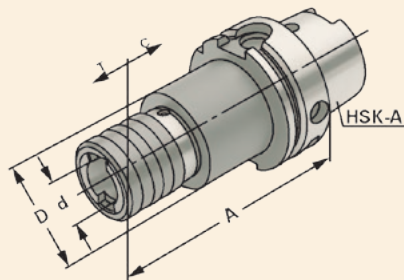

ISO 12164-1

DIN 69893-1

HSK-A

Order no.	Taper	Range	Size	A	D	d	C	T
HSK.63A-QTCC.M3.M14	HSK-A 63	M3 – M14	1	102	38	19	7	7
HSK.63A-QTCC.M5.M22	HSK-A 63	M5 – M22	2	140	54	31	12	12
HSK.100A-QTCC.M3.M14	HSK-A 100	M3 – M14	1	112	38	19	7	7
HSK.100A-QTCC.M5.M22	HSK-A 100	M5 – M22	2	148	54	31	12	12
HSK.100A-QTCC.M14.M36	HSK-A 100	M14 – M36	3	144	86	48	17,5	17,5

Note: For machining centres without synchronous spindle.



DIN 69871

ISO 60

MAS 403 BT

DIN 2080

HSK-A

VDI

MORSE



HSK-A-QTCW

QUICK-CHANGE TAPPING CHUCKS WITHOUT COMPENSATION



Application:
For the chucking of quick change adaptors for taps.

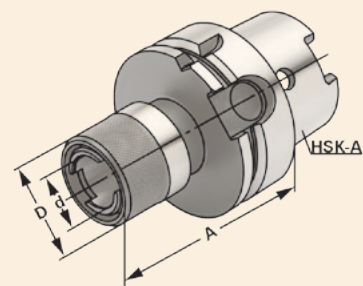

ISO 12164-1

DIN 69893-1

HSK-A

Order no.	Taper	Range	Size	A	D	d
HSK.63A-QTCW.M3.M14	HSK-A 63	M3 – M14	1	65	38	19
HSK.63A-QTCW.M5.M22	HSK-A 63	M5 – M22	2	100	54	31
HSK.100A-QTCW.M3.M14	HSK-A 100	M3 – M14	1	80	38	19
HSK.100A-QTCW.M5.M22	HSK-A 100	M5 – M22	2	90	54	31
HSK.100A-QTCW.M14.M36	HSK-A 100	M14 – M36	3	132,5	86	48

Note: For machining centres with synchronous spindle.



222 - 224



225 - 227



228



248



248



HSK-A-DC

DRILL CHUCK HOLDERS



Application:
For mounting tools with straight shanks.

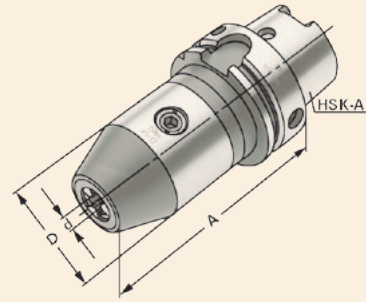

ISO 12164-1

DIN 69893-1

HSK-A

$\nabla \leq 0,003$

G6,3
15.000 min⁻¹

Order no.	Taper	Range	A	D
HSK.63A-DC.08.090	HSK-A 63	0,5 – 8	85	36
HSK.63A-DC.13.104	HSK-A 63	1 – 13	104	50
HSK.63A-DC.16.109	HSK-A 63	2,5 – 16	109	50
HSK.100A-DC.13.107	HSK-A 100	1 – 13	107	50
HSK.100A-DC.16.112	HSK-A 100	2,5 – 16	112	50

Note: High precision and accurate concentricity of ≤ 0.03 mm. Secure gripping of the tool through mechanical amplification of the clamping force. No automatic slackening of the clamping force while machining with either clockwise or counter clockwise rotation or on spindle stop. Clamping and releasing effected by means of an Allen wrench.

Delivery: **With wrench**



DIN 69871

ISO 60

MAS 403 BT

DIN 2080

HSK-A

VDI

MORSE



HSK-A-HC

HYDRAULIC CHUCKS



Application:

For mounting straight-shank tools acc. DIN 1835 form A+B+E and DIN 6535 form HA+HB+HE (for dia. 20 mm or 32 mm reduction sleeve can be used).

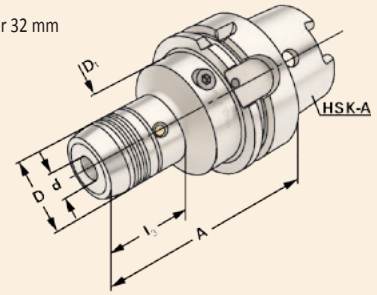

ISO 12164-1

DIN 69893-1

HSK-A

$\nabla \leq 0,003$

G6,3
15.000 min⁻¹

Order no.	Taper	d	A	D	D ₁	l ₃
HSK.63A-HC.06.080	HSK-A 63	6	80	26	50	47
HSK.63A-HC.08.080	HSK-A 63	8	80	28	50	47
HSK.63A-HC.10.085	HSK-A 63	10	85	30	50	46
HSK.63A-HC.12.090	HSK-A 63	12	90	32	50	46
HSK.63A-HC.14.090	HSK-A 63	14	90	34	50	44
HSK.63A-HC.16.095	HSK-A 63	16	95	38	50	43
HSK.63A-HC.18.095	HSK-A 63	18	95	40	50	43
HSK.63A-HC.20.100	HSK-A 63	20	100	42	50	42
HSK.63A-HC.25.120	HSK-A 63	25	120	50	50	26
HSK.63A-HC.32.125	HSK-A 63	32	125	60	50	42
HSK.63A-HC.06.150	HSK-A 63	6	150	26	50	47
HSK.63A-HC.08.150	HSK-A 63	8	150	28	50	46
HSK.63A-HC.10.150	HSK-A 63	10	150	30	50	46
HSK.63A-HC.12.150	HSK-A 63	12	150	32	50	45
HSK.63A-HC.14.150	HSK-A 63	14	150	34	50	45
HSK.63A-HC.16.150	HSK-A 63	16	150	38	50	43,5
HSK.63A-HC.18.150	HSK-A 63	18	150	40	50	43
HSK.63A-HC.20.150	HSK-A 63	20	150	42	50	42
HSK.63A-HC.25.150	HSK-A 63	25	150	50	50	-
HSK.63A-HC.06.200	HSK-A 63	6	200	26	50	47
HSK.63A-HC.08.200	HSK-A 63	8	200	28	50	46
HSK.63A-HC.10.200	HSK-A 63	10	200	30	50	46
HSK.63A-HC.12.200	HSK-A 63	12	200	32	50	45
HSK.63A-HC.14.200	HSK-A 63	14	200	34	50	45
HSK.63A-HC.16.200	HSK-A 63	16	200	38	50	43,5
HSK.63A-HC.18.200	HSK-A 63	18	200	40	50	43
HSK.63A-HC.20.200	HSK-A 63	20	200	42	50	42
HSK.63A-HC.25.200	HSK-A 63	25	200	50	50	-

Delivery: With wrench



HSK-A-HC

HYDRAULIC CHUCKS



Application:

For mounting straight-shank tools acc. DIN 1835 form A+B+E and DIN 6535 form HA+HB+HE (for dia. 20 mm or 32 mm reduction sleeve can be used).

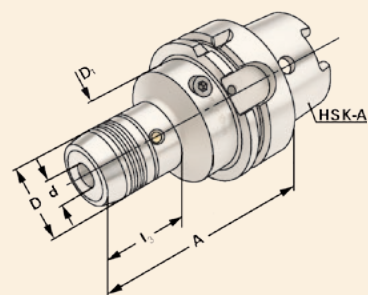

ISO 12164-1

DIN 69893-1

HSK-A

$\nabla \leq 0,003$

G6,3
15.000 min⁻¹

Order no.	Taper	d	A	D	D ₁	l ₃
HSK.100A-HC.06.085	HSK-A 100	6	85	26	63	56
HSK.100A-HC.08.085	HSK-A 100	8	85	28	63	56
HSK.100A-HC.10.090	HSK-A 100	10	90	30	63	55
HSK.100A-HC.12.095	HSK-A 100	12	95	32	63	55
HSK.100A-HC.14.095	HSK-A 100	14	95	34	63	53
HSK.100A-HC.16.100	HSK-A 100	16	100	38	63	53
HSK.100A-HC.18.100	HSK-A 100	18	100	40	63	52
HSK.100A-HC.20.105	HSK-A 100	20	105	42	63	51
HSK.100A-HC.25.115	HSK-A 100	25	115	50	63	64
HSK.100A-HC.32.120	HSK-A 100	32	120	60	63	61
HSK.100A-HC.06.150	HSK-A 100	6	150	26	50	56
HSK.100A-HC.08.150	HSK-A 100	8	150	28	50	55,5
HSK.100A-HC.10.150	HSK-A 100	10	150	30	50	55
HSK.100A-HC.12.150	HSK-A 100	12	150	32	50	54,5
HSK.100A-HC.14.150	HSK-A 100	14	150	34	50	53
HSK.100A-HC.16.150	HSK-A 100	16	150	38	50	52,5
HSK.100A-HC.18.150	HSK-A 100	18	150	40	50	52
HSK.100A-HC.20.150	HSK-A 100	20	150	42	50	51
HSK.100A-HC.25.150	HSK-A 100	25	150	50	50	-
HSK.100A-HC.32.150	HSK-A 100	32	150	60	60	-

Delivery: With wrench



DIN 69871

ISO 60

MAS 403 BT

DIN 2080

HSK-A

VDI

MORSE



HSK-A-HC

HYDRAULIC CHUCKS



Application:

For mounting straight-shank tools acc. DIN 1835 form A+B+E and DIN 6535 form HA+HB+HE (for dia. 20 mm or 32 mm reduction sleeve can be used).

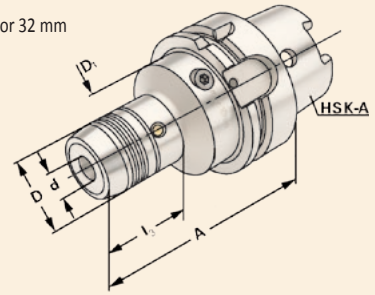

ISO 12164-1

DIN 69893-1

HSK-A

$\nabla \leq 0,003$

G6,3
15.000 min⁻¹

Order no.	Taper	d	A	D	D ₁	l ₃
HSK.100A-HC.06.200	HSK-A 100	6	200	26	50	56
HSK.100A-HC.08.200	HSK-A 100	8	200	28	50	55,5
HSK.100A-HC.10.200	HSK-A 100	10	200	30	50	55
HSK.100A-HC.12.200	HSK-A 100	12	200	32	50	54,5
HSK.100A-HC.14.200	HSK-A 100	14	200	34	50	53
HSK.100A-HC.16.200	HSK-A 100	16	200	38	50	52,5
HSK.100A-HC.18.200	HSK-A 100	18	200	40	50	52
HSK.100A-HC.20.200	HSK-A 100	20	200	42	50	51
HSK.100A-HC.25.200	HSK-A 100	25	200	50	50	–
HSK.100A-HC.32.200	HSK-A 100	32	200	60	60	–

Delivery: **With wrench**



HSK-A-SC

SHRINK FIT HOLDERS



Application:
For mounting straight-shank tools.

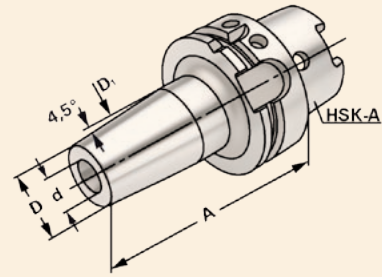

ISO 12164-1

DIN 69893-1

HSK-A

$\sqrt{\text{R}} \leq 0,003$

G6,3
15.000 min⁻¹

Order no.	Taper	d	A	D	D ₁
HSK.63A-SC.03.080	HSK-A 63	3	80	11	15
HSK.63A-SC.04.080	HSK-A 63	4	80	14	22
HSK.63A-SC.05.080	HSK-A 63	5	80	16	22
HSK.63A-SC.06.080	HSK-A 63	6	80	21	27
HSK.63A-SC.08.080	HSK-A 63	8	80	21	27
HSK.63A-SC.10.085	HSK-A 63	10	85	24	32
HSK.63A-SC.12.090	HSK-A 63	12	90	24	32
HSK.63A-SC.14.090	HSK-A 63	14	90	27	34
HSK.63A-SC.16.095	HSK-A 63	16	95	27	34
HSK.63A-SC.18.095	HSK-A 63	18	95	33	42
HSK.63A-SC.20.100	HSK-A 63	20	100	33	42
HSK.63A-SC.25.115	HSK-A 63	25	115	44	53
HSK.63A-SC.32.120	HSK-A 63	32	120	44	53
HSK.63A-SC.03.120	HSK-A 63	3	120	11	15
HSK.63A-SC.04.120	HSK-A 63	4	120	14	22
HSK.63A-SC.05.120	HSK-A 63	5	120	16	22
HSK.63A-SC.06.120	HSK-A 63	6	120	21	27
HSK.63A-SC.08.120	HSK-A 63	8	120	21	27
HSK.63A-SC.10.120	HSK-A 63	10	120	24	32
HSK.63A-SC.12.120	HSK-A 63	12	120	24	32
HSK.63A-SC.14.120	HSK-A 63	14	120	27	34
HSK.63A-SC.16.120	HSK-A 63	16	120	27	34
HSK.63A-SC.18.120	HSK-A 63	18	120	33	42
HSK.63A-SC.20.120	HSK-A 63	20	120	33	42
HSK.63A-SC.25.120	HSK-A 63	25	120	44	53

For \varnothing 3, 4 and 5 mm only solid carbide tool shanks must be used!

Note: Toolholders suitable for induction-, contact- and hot air shrink units.
 \varnothing 3, 4, 5 with h4-tolerance and \varnothing 6 – \varnothing 32 with h6-tolerance



DIN 69871

ISO 60

MAS 403 BT

DIN 2080

HSK-A

VDI

MORSE



HSK-A-SC

SHRINK FIT HOLDERS



Application:
For mounting straight-shank tools.

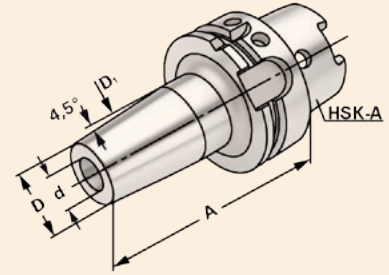

ISO 12164-1

DIN 69893-1

HSK-A

$\nabla \leq 0,003$

G6,3
15.000 min⁻¹

Order no.	Taper	d	A	D	D ₁
HSK.63A-SC.03.160	HSK-A 63	3	160	11	15
HSK.63A-SC.04.160	HSK-A 63	4	160	14	22
HSK.63A-SC.05.160	HSK-A 63	5	160	16	22
HSK.63A-SC.06.160	HSK-A 63	6	160	21	27
HSK.63A-SC.08.160	HSK-A 63	8	160	21	27
HSK.63A-SC.10.160	HSK-A 63	10	160	24	32
HSK.63A-SC.12.160	HSK-A 63	12	160	24	32
HSK.63A-SC.14.160	HSK-A 63	14	160	27	34
HSK.63A-SC.16.160	HSK-A 63	16	160	27	34
HSK.63A-SC.18.160	HSK-A 63	18	160	33	42
HSK.63A-SC.20.160	HSK-A 63	20	160	33	42
HSK.63A-SC.25.160	HSK-A 63	25	160	44	53
HSK.63A-SC.32.160	HSK-A 63	32	160	44	53
HSK.63A-SC.06.200	HSK-A 63	6	200	21	27
HSK.63A-SC.08.200	HSK-A 63	8	200	21	27
HSK.63A-SC.10.200	HSK-A 63	10	200	24	32
HSK.63A-SC.12.200	HSK-A 63	12	200	24	32
HSK.63A-SC.14.200	HSK-A 63	14	200	27	34
HSK.63A-SC.16.200	HSK-A 63	16	200	27	34
HSK.63A-SC.18.200	HSK-A 63	18	200	33	42
HSK.63A-SC.20.200	HSK-A 63	20	200	33	42
HSK.63A-SC.25.200	HSK-A 63	25	200	44	53
HSK.63A-SC.32.200	HSK-A 63	32	200	44	53

For \varnothing 3, 4 and 5 mm only solid carbide tool shanks must be used!

Note: Toolholders suitable for induction-, contact- and hot air shrink units.
 \varnothing 3, 4, 5 with h4-tolerance and \varnothing 6 – \varnothing 32 with h6-tolerance



HSK-A-SC

SHRINK FIT HOLDERS



Application:
For mounting straight-shank tools.

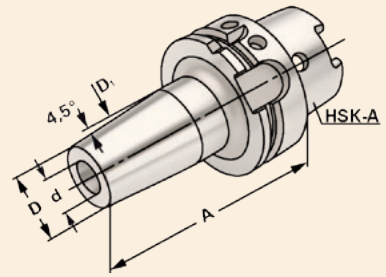

ISO 12164-1

DIN 69893-1

HSK-A

$\sqrt{\leq 0,003}$

G6,3
15.000 min⁻¹

Order no.	Taper	d	A	D	D ₁
HSK.100A-SC.04.085	HSK-A 100	4	85	14	22
HSK.100A-SC.05.085	HSK-A 100	5	85	16	22
HSK.100A-SC.06.085	HSK-A 100	6	85	21	27
HSK.100A-SC.08.085	HSK-A 100	8	85	21	27
HSK.100A-SC.10.090	HSK-A 100	10	90	24	32
HSK.100A-SC.12.095	HSK-A 100	12	95	24	32
HSK.100A-SC.14.095	HSK-A 100	14	95	27	34
HSK.100A-SC.16.100	HSK-A 100	16	100	27	34
HSK.100A-SC.18.100	HSK-A 100	18	100	33	42
HSK.100A-SC.20.105	HSK-A 100	20	105	33	42
HSK.100A-SC.25.120	HSK-A 100	25	120	44	53
HSK.100A-SC.32.120	HSK-A 100	32	120	44	53
HSK.100A-SC.40.150	HSK-A 100	40	150	78	90
HSK.100A-SC.50.150	HSK-A 100	50	150	78	90
HSK.100A-SC.06.120	HSK-A 100	6	120	21	27
HSK.100A-SC.08.120	HSK-A 100	8	120	21	27
HSK.100A-SC.10.120	HSK-A 100	10	120	24	32
HSK.100A-SC.12.120	HSK-A 100	12	120	24	32
HSK.100A-SC.14.120	HSK-A 100	14	120	27	34
HSK.100A-SC.16.120	HSK-A 100	16	120	27	34
HSK.100A-SC.18.120	HSK-A 100	18	120	33	42
HSK.100A-SC.20.120	HSK-A 100	20	120	33	42

Note: Toolholders suitable for induction-, contact- and hot air shrink units.
Ø 4, 5 with h4-tolerance and Ø 6 – Ø 32 with h6-tolerance



DIN 69871

ISO 60

MAS 403 BT

DIN 2080

HSK-A

VDI

MORSE



HSK-A-SC

SHRINK FIT HOLDERS



Application:
For mounting straight-shank tools.

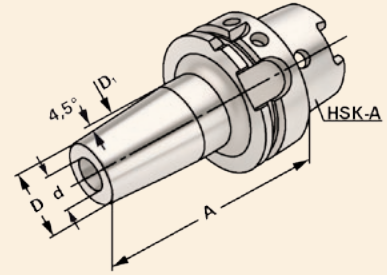

ISO 12164-1

DIN 69893-1

HSK-A

$\nabla \leq 0,003$

G6,3
15.000 min⁻¹

Order no.	Taper	d	A	D	D ₁
HSK.100A-SC.06.160	HSK-A 100	6	160	21	27
HSK.100A-SC.08.160	HSK-A 100	8	160	21	27
HSK.100A-SC.10.160	HSK-A 100	10	160	24	32
HSK.100A-SC.12.160	HSK-A 100	12	160	24	32
HSK.100A-SC.14.160	HSK-A 100	14	160	27	34
HSK.100A-SC.16.160	HSK-A 100	16	160	27	34
HSK.100A-SC.18.160	HSK-A 100	18	160	33	42
HSK.100A-SC.20.160	HSK-A 100	20	160	33	42
HSK.100A-SC.25.160	HSK-A 100	25	160	44	53
HSK.100A-SC.32.160	HSK-A 100	32	160	44	53
HSK.100A-SC.06.200	HSK-A 100	6	200	21	27
HSK.100A-SC.08.200	HSK-A 100	8	200	21	27
HSK.100A-SC.10.200	HSK-A 100	10	200	24	32
HSK.100A-SC.12.200	HSK-A 100	12	200	24	32
HSK.100A-SC.14.200	HSK-A 100	14	200	27	34
HSK.100A-SC.16.200	HSK-A 100	16	200	27	34
HSK.100A-SC.18.200	HSK-A 100	18	200	33	42
HSK.100A-SC.20.200	HSK-A 100	20	200	33	42
HSK.100A-SC.25.200	HSK-A 100	25	200	44	53
HSK.100A-SC.32.200	HSK-A 100	32	200	44	53

Note: Toolholders suitable for induction-, contact- and hot air shrink units.
∅ 6 – ∅ 32 with h6-tolerance



248

248

HSK-A-SC-C

SHRINK FIT HOLDERS WITH COOLANT CHANNELS



Application:
For mounting straight-shank tools.

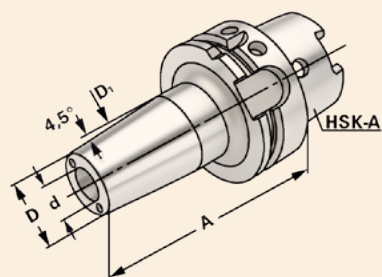

ISO 12164-1

DIN 69893-1

HSK-A

$\sqrt{\leq 0,003}$

G6,3
15.000 min⁻¹

Order no.	Taper	d	A	D	D ₁
HSK.63A-SC.06.080.C	HSK-A 63	6	80	21	27
HSK.63A-SC.08.080.C	HSK-A 63	8	80	21	27
HSK.63A-SC.10.085.C	HSK-A 63	10	85	24	32
HSK.63A-SC.12.090.C	HSK-A 63	12	90	24	32
HSK.63A-SC.14.090.C	HSK-A 63	14	90	27	34
HSK.63A-SC.16.095.C	HSK-A 63	16	95	27	34
HSK.63A-SC.18.095.C	HSK-A 63	18	95	33	42
HSK.63A-SC.20.100.C	HSK-A 63	20	100	33	42
HSK.63A-SC.25.115.C	HSK-A 63	25	115	44	53
HSK.63A-SC.32.120.C	HSK-A 63	32	120	44	53

Note: Toolholders suitable for induction-, contact- and hot air shrink units.
Ø 6 – Ø 32 with h6-tolerance



DIN 69871

ISO 60

MAS 403 BT

DIN 2080

HSK-A

VDI

MORSE



HSK-A-SC-C

SHRINK FIT HOLDERS WITH COOLANT CHANNELS



Application:
For mounting straight-shank tools.

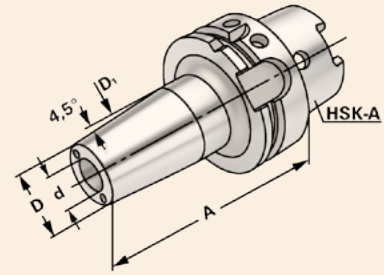

ISO 12164-1

DIN 69893-1

HSK-A

$\nabla \leq 0,003$

G6,3
15.000 min⁻¹

Order no.	HSK	d	A	D	D ₁
HSK.63A-SC.06.160.C	HSK-A 63	6	160	21	27
HSK.63A-SC.08.160.C	HSK-A 63	8	160	21	27
HSK.63A-SC.10.160.C	HSK-A 63	10	160	24	32
HSK.63A-SC.12.160.C	HSK-A 63	12	160	24	32
HSK.63A-SC.14.160.C	HSK-A 63	14	160	27	34
HSK.63A-SC.16.160.C	HSK-A 63	16	160	27	34
HSK.63A-SC.18.160.C	HSK-A 63	18	160	33	42
HSK.63A-SC.20.160.C	HSK-A 63	20	160	33	42
HSK.63A-SC.25.160.C	HSK-A 63	25	160	44	53
HSK.63A-SC.32.160.C	HSK-A 63	32	160	44	53
HSK.100A-SC.06.085.C	HSK-A 100	6	85	21	27
HSK.100A-SC.08.085.C	HSK-A 100	8	85	21	27
HSK.100A-SC.10.090.C	HSK-A 100	10	90	24	32
HSK.100A-SC.12.095.C	HSK-A 100	12	95	24	32
HSK.100A-SC.14.095.C	HSK-A 100	14	95	27	34
HSK.100A-SC.16.100.C	HSK-A 100	16	100	27	34
HSK.100A-SC.18.100.C	HSK-A 100	18	100	33	42
HSK.100A-SC.20.105.C	HSK-A 100	20	105	33	42
HSK.100A-SC.25.115.C	HSK-A 100	25	115	44	53
HSK.100A-SC.32.120.C	HSK-A 100	32	120	44	53
HSK.100A-SC.06.160.C	HSK-A 100	6	160	21	27
HSK.100A-SC.08.160.C	HSK-A 100	8	160	21	27
HSK.100A-SC.10.160.C	HSK-A 100	10	160	24	32
HSK.100A-SC.12.160.C	HSK-A 100	12	160	24	32
HSK.100A-SC.14.160.C	HSK-A 100	14	160	27	34
HSK.100A-SC.16.160.C	HSK-A 100	16	160	27	34
HSK.100A-SC.18.160.C	HSK-A 100	18	160	33	42
HSK.100A-SC.20.160.C	HSK-A 100	20	160	33	42
HSK.100A-SC.25.160.C	HSK-A 100	25	160	44	53
HSK.100A-SC.32.160.C	HSK-A 100	32	160	44	53

Note:

Toolholders suitable for induction-, contact- and hot air shrink units.
Ø 3, 4, 5 with h4-tolerance and Ø 6 – Ø 32 with h6-tolerance



248

248



HSK-A-IHA

HOLDERS FOR MILLING CUTTERS WITH THREADED END (EXCHANGEABLE HEAD)



Application:
For mounting screw-in cutters with thread.

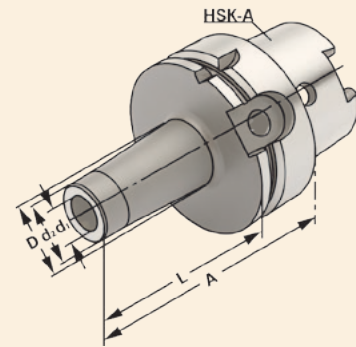

ISO 12164-1

DIN 69893-1

HSK-A

$\sqrt{\text{R}} \leq 0,003$

G6,3
15.000 min⁻¹

Order no.	Taper	M	d _{1H4}	d ₂	D	A	L
HSK.63A-IHA.M6.025	HSK-A 63	6	6,5	10	13	51	25
HSK.63A-IHA.M8.025	HSK-A 63	8	8,5	13	15	51	25
HSK.63A-IHA.M8.050	HSK-A 63	8	8,5	13	23	76	50
HSK.63A-IHA.M8.075	HSK-A 63	8	8,5	13	23	101	75
HSK.63A-IHA.M10.025	HSK-A 63	10	10,5	18	20	51	25
HSK.63A-IHA.M10.050	HSK-A 63	10	10,5	18	23	76	50
HSK.63A-IHA.M10.100	HSK-A 63	10	10,5	18	32	126	100
HSK.63A-IHA.M10.150	HSK-A 63	10	10,5	18	37	176	150
HSK.63A-IHA.M12.025	HSK-A 63	12	12,5	21	24	51	25
HSK.63A-IHA.M12.050	HSK-A 63	12	12,5	21	24	76	50
HSK.63A-IHA.M12.075	HSK-A 63	12	12,5	21	31	101	75
HSK.63A-IHA.M12.100	HSK-A 63	12	12,5	21	33	126	100
HSK.63A-IHA.M12.150	HSK-A 63	12	12,5	21	40	176	150
HSK.63A-IHA.M16.025	HSK-A 63	16	17	29	29	51	25
HSK.63A-IHA.M16.050	HSK-A 63	16	17	29	34	76	50
HSK.63A-IHA.M16.075	HSK-A 63	16	17	29	34	101	75
HSK.63A-IHA.M16.100	HSK-A 63	16	17	29	36	126	100
HSK.63A-IHA.M16.150	HSK-A 63	16	17	29	43	176	150
HSK.100A-IHA.M8.050	HSK-A 100	8	8,5	13	23	79	50
HSK.100A-IHA.M10.050	HSK-A 100	10	10,5	18	23	79	50
HSK.100A-IHA.M10.100	HSK-A 100	10	10,5	18	32	129	100
HSK.100A-IHA.M10.150	HSK-A 100	10	10,5	18	37	179	150
HSK.100A-IHA.M12.050	HSK-A 100	12	12,5	21	24	79	50
HSK.100A-IHA.M12.100	HSK-A 100	12	12,5	21	33	129	100
HSK.100A-IHA.M12.150	HSK-A 100	12	12,5	21	40	179	150
HSK.100A-IHA.M16.050	HSK-A 100	16	17	29	34	79	50
HSK.100A-IHA.M16.100	HSK-A 100	16	17	29	36	129	100
HSK.100A-IHA.M16.150	HSK-A 100	16	17	29	43	179	150

Note: From d = 25 on two clamping screws



Delivery: With clamping screw and axial adjustment bolt

DIN 69871

ISO 60

MAS 403 BT

DIN 2080

HSK-A

VDI

MORSE



HSK-A-BLANKS

BLANKS FOR SPECIAL HOLDERS



Application:
For the manufacturing of special tools.

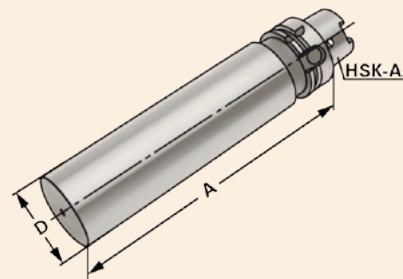

ISO 12164-1

DIN 69893-1

HSK-A

Order no.	Taper	D	A
HSK.63A-BLA.63.250	HSK-A 63	63,5	250
HSK.63A-BLA.80.250	HSK-A 63	80	250
HSK.100A-BLA.97.250	HSK-A 100	97,5	250

Version: **Cone and flange hardened and grinded. Soft body for later processing.**

DIN 69871

ISO 60

MAS 403 BT

DIN 2080

HSK-A

VDI

MORSE



HSK-A-TA

TEST ARBORS



Application:
For the inspection of machine tools according to ISO recommendation R230 or for testing the tool spindle.

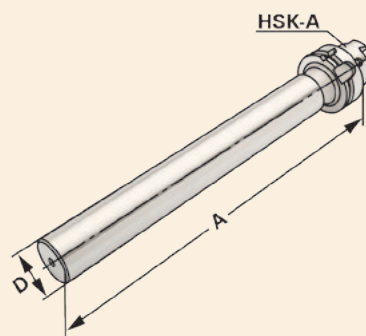

ISO 12164-1

DIN 69893-1

HSK-A

Order no.	Taper	D	A	Tolerance	Max. concentricity deviation
HSK.63A.TA.40.346	HSK-A 63	40	346	0,003	0,003
HSK.100A.TA.50.349	HSK-A 100	50	349	0,003	0,003

DIN 69871

ISO 60

MAS 403 BT

DIN 2080

HSK-A

VDI

MORSE



VDI



VDI toolholders DIN 69880 (DIN ISO 10889-1)

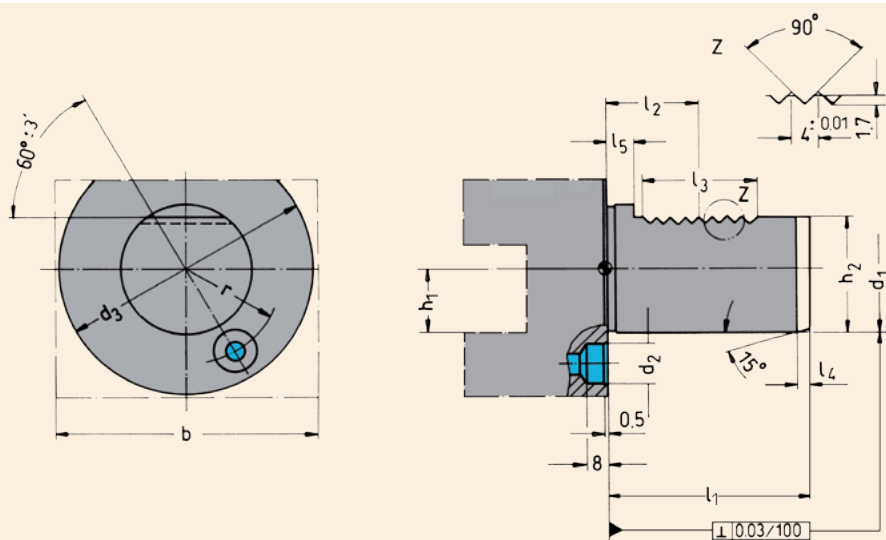

d_1 h_2	b	h_1 max.	d_2	d_3	h_2 $\pm 0,1$	r $\pm 0,02$	l_1 max.	l_2 $\pm 0,05$	l_3 max.	l_4 max.	l_5
30	70	20	14	68	27,0	25,0	55	29,7	40	2	7,0
40	85	25	14	83	36,0	32,0	63	29,7	40	3	7,0
50	100	32	16	98	45,0	37,0	78	35,7	48	3	8,0

Material: Alloyed case-hardened steel, tensile core strength of min. 1200 N / mm².
Case hardened HRC 60 ± 2 (HV 700 ± 50), hardening depth 0.8 mm ± 0.2 mm,
black-finished and precisely grinded.

Version: With internal coolant resp. with threaded connection for external coolant.

DIN 69871

ISO 60

MAS 403 BT

DIN 2080

HSK-A

VDI

MORSE



Tool assignment for disc turrets

Application of tool holders with anti-clockwise spindle rotation

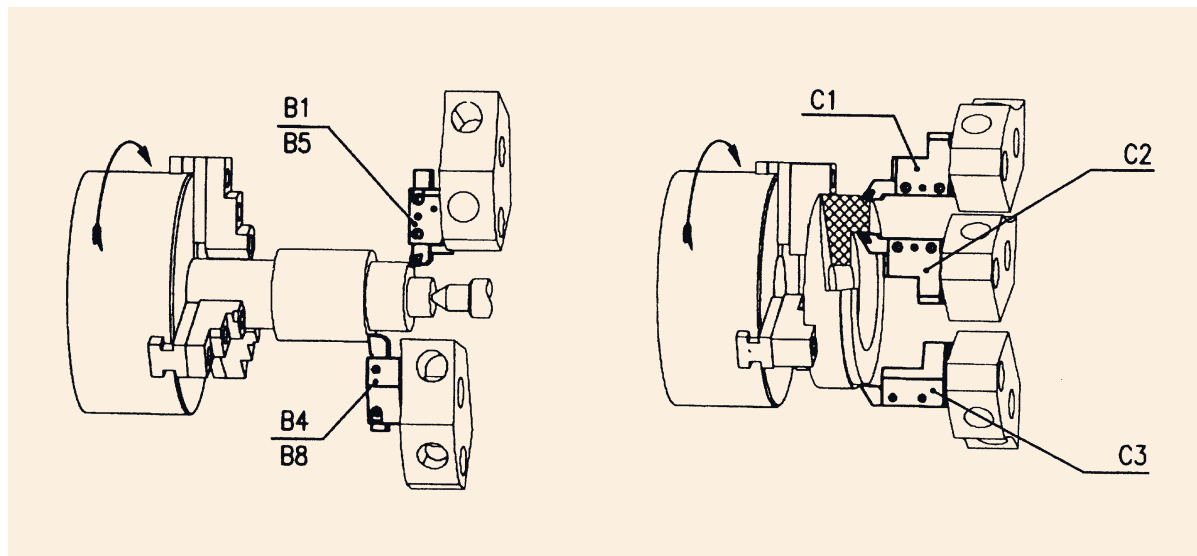

Application of tool holders with clockwise spindle rotation

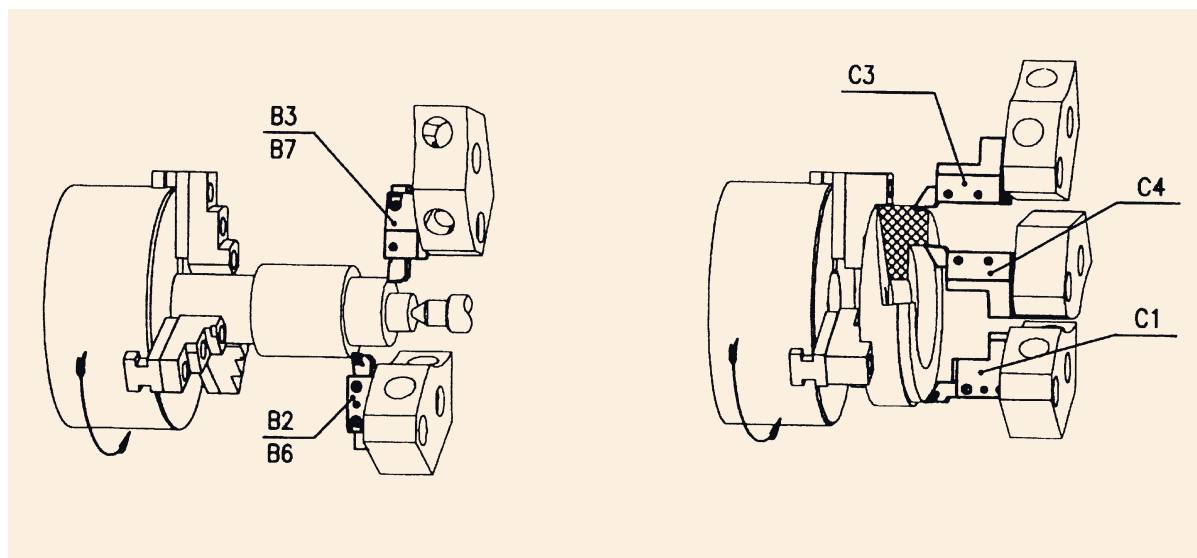

DIN 69871

ISO 60

MAS 403 BT

DIN 2080

HSK-A

VDI

MORSE



VDI-B1



132

VDI-B2



133

VDI-B3



134

VDI-B4



135

VDI-B5



136

VDI-B6



137

VDI-B7



138

VDI-B8



139

VDI-C1



140

VDI-C2



141

VDI-C3



142

VDI-C4



143

VDI-D1



144

VDI-D2



145

VDI-AR



146

VDI-AL



147

VDI-E1



148

VDI-E2



149

VDI-E3



150

VDI-E4



151

VDI-F1



152

DIN 69871

ISO 60

MAS 403 BT

DIN 2080

HSK-A

VDI

MORSE





VDI-HC



153

VDI-Z2-S



154

VDI-Z2-P



155

VDI-DC



156

VDI-DC-C



157

VDI-QTCC



158

VDI-QTCW



159

VDI-A1



160

VDI-A2



161

VDI-TA



162

DIN 69871

ISO 60

MAS 403 BT

DIN 2080

HSK-A

VDI

MORSE



VDI-B1

RADIAL HOLDERS FORM B1 - RIGHT - SHORT



Application:
Mainly for external machining.
For face machining.

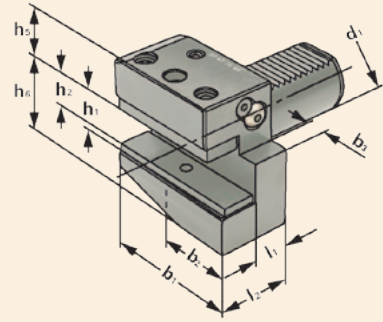

DIN ISO 10889

B1

Order no.	Size	d_1	h_1	h_2	l_2	l_1	b_1	b_2	b_3	h_5	h_6
VDI.30-B1.20.40	B1 – 30 × 20 × 40	30	20	16	40	22	70	35	10	28	38
VDI.40-B1.25.44	B1 – 40 × 25 × 44	40	25	20	44	22	85	42,5	12,5	32,5	48
VDI.50-B1.32.55	B1 – 50 × 32 × 55	50	32	25	55	30	100	50	16	35	60

Version: **With adjustable spray nozzle and shim**



VDI-B2

RADIAL HOLDERS FORM B2 - LEFT - SHORT



Application:
Mainly for external machining.
For face machining.

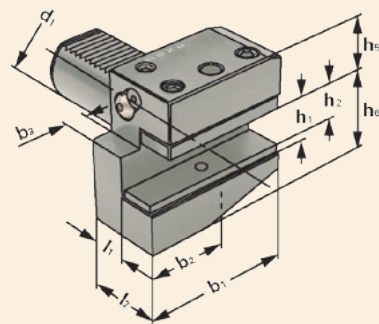

DIN ISO 10889

B2

Order no.	Size	d_1	h_1	h_2	l_2	l_1	b_1	b_2	b_3	h_5	h_6
VDI.30-B2.20.40	B2 – 30 × 20 × 40	30	20	16	40	22	70	35	10	28	38
VDI.40-B2.25.44	B2 – 40 × 25 × 44	40	25	20	44	22	85	42,5	12,5	32,5	48
VDI.50-B2.32.55	B2 – 50 × 32 × 55	50	32	25	55	30	100	50	16	35	60

Version: **With adjustable spray nozzle and shim**



DIN 69871

ISO 60

MAS 403 BT

DIN 2080

HSK-A

VDI

MORSE



VDI-B3

RADIAL HOLDERS FORM B3 UPSIDE-DOWN - RIGHT - SHORT



Application:
Mainly for external machining.
For face machining.

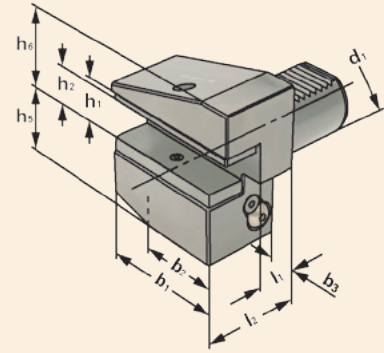

DIN ISO 10889

B3

Order no.	Size	d_1	h_1	h_2	l_2	l_1	b_1	b_2	b_3	h_5	h_6
VDI.30-B3.20.40	B3 – 30 × 20 × 40	30	20	16	40	22	70	35	10	35	38
VDI.40-B3.25.44	B3 – 40 × 25 × 44	40	25	20	44	22	85	42,5	12,5	42,5	48
VDI.50-B3.32.55	B3 – 50 × 32 × 55	50	32	25	55	30	100	50	16	50	60

Version: **With adjustable spray nozzle and shim**



VDI-B4

RADIAL HOLDERS FORM B4 UPSIDE-DOWN - LEFT - SHORT



Application:
Mainly for external machining.
For face machining.

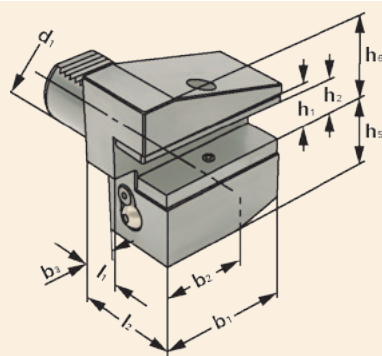

DIN ISO 10889

B4

Order no.	Size	d_1	h_1	h_2	l_2	l_1	b_1	b_2	b_3	h_5	h_6
VDI.30-B4.20.40	B4 – 30 × 20 × 40	30	20	16	40	22	70	35	10	35	38
VDI.40-B4.25.44	B4 – 40 × 25 × 44	40	25	20	44	22	85	42,5	12,5	42,5	48
VDI.50-B4.32.55	B4 – 50 × 32 × 55	50	32	25	55	30	100	50	16	50	60

Version: **With adjustable spray nozzle and shim**



DIN 69871

ISO 60

MAS 403 BT

DIN 2080

HSK-A

VDI

MORSE



VDI-B5

RADIAL HOLDERS FORM B5 - RIGHT - LONG



Application:
Mainly for external machining.
For face machining.

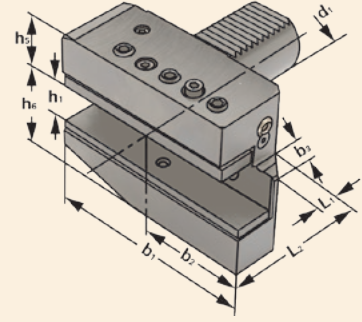

DIN ISO 10889

B5

Order no.	Size	d_1	b_1	b_2	b_3	L_1	L_2	h_1	h_5	h_6
VDI.30-B5.20.40	B5 – 30 × 20 × 40	30	100	65	10	22	40	20	28	38
VDI.40-B5.25.44	B5 – 40 × 25 × 44	40	118	75,5	12,5	22	44	25	32,5	48
VDI.50-B5.32.55	B5 – 50 × 32 × 55	50	130	80	16	30	55	32	35	60

Version: **With adjustable spray nozzle and shim**



VDI-B6

RADIAL HOLDERS FORM B6 - LEFT - LONG



Application:
Mainly for external machining.
For face machining.

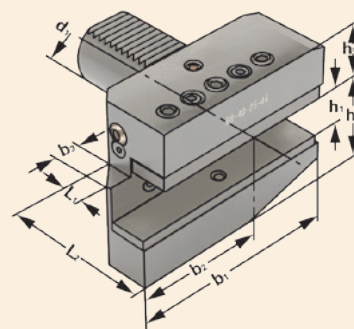

DIN ISO 10889

B6

Order no.	Size	d_1	b_1	b_2	b_3	L_1	L_2	h_1	h_5	h_6
VDI.30-B6.20.40	B6 – 30 × 20 × 40	30	100	65	10	22	40	20	28	38
VDI.40-B6.25.44	B6 – 40 × 25 × 44	40	118	75,5	12,5	22	44	25	32,5	48
VDI.50-B6.32.55	B6 – 50 × 32 × 55	50	130	80	16	30	55	32	35	60

Version: **With adjustable spray nozzle and shim**



DIN 69871

ISO 60

MAS 403 BT

DIN 2080

HSK-A

VDI

MORSE



VDI-B7

RADIAL HOLDERS FORM B7 - UPSIDE-DOWN - RIGHT - LONG



Application:
Mainly for external machining.
For face machining.

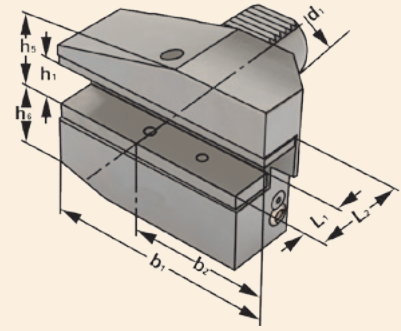

DIN ISO 10889

B7

Order no.	Size	d_1	b_1	b_2	b_3	L_1	L_2	h_1	h_5	h_6
VDI.30-B7.20.40	B7 – 30 × 20 × 40	30	100	65	10	22	40	20	38	35
VDI.40-B7.25.44	B7 – 40 × 25 × 44	40	118	75,5	12,5	22	44	25	48	42,5
VDI.50-B7.32.55	B7 – 50 × 32 × 55	50	130	80	16	30	55	32	60	50

Version: **With adjustable spray nozzle and shim**



- DIN 69871
- ISO 60
- MAS 403 BT
- DIN 2080
- HSK-A
- VDI
- MORSE
-
-
-
-

VDI-B8

RADIAL HOLDERS FORM B8 - UPSIDE-DOWN - LEFT - LONG



Application:
Mainly for external machining.
For face machining.

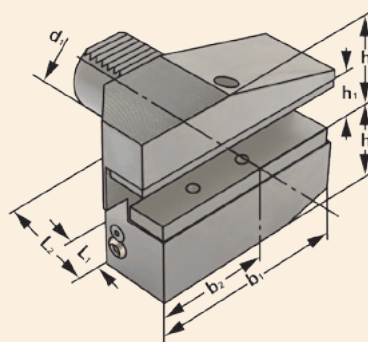

DIN ISO 10889

B8

Order no.	Size	d_1	b_1	b_2	b_3	L_1	L_2	h_1	h_5	h_6
VDI.30-B8.20.40	B8 – 30 × 20 × 40	30	100	65	10	22	40	20	38	35
VDI.40-B8.25.44	B8 – 40 × 25 × 44	40	118	75,5	12,5	22	44	25	48	42,5
VDI.50-B8.32.55	B8 – 50 × 32 × 55	50	130	80	16	30	55	32	60	50

Version: **With adjustable spray nozzle and shim**



DIN 69871

ISO 60

MAS 403 BT

DIN 2080

HSK-A

VDI

MORSE



VDI-C1

AXIAL HOLDERS FORM C1 - RIGHT



Application:
Mainly for external machining.
For face machining.

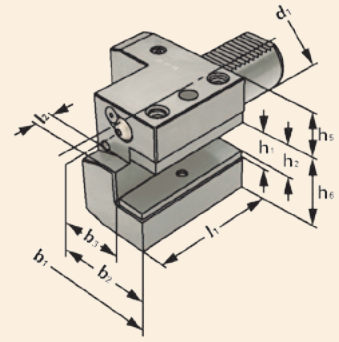

DIN ISO 10889

C1

Order no.	Size	d_1	h_1	h_2	b_1	b_2	b_3	l_1	l_2	h_5	h_6
VDI.30-C1.20	C1 – 30 × 20	30	20	16	70	35	17	70	10	28	38
VDI.40-C1.25	C1 – 40 × 25	40	25	20	85	42,5	21	85	12,5	32,5	48
VDI.50-C1.32	C1 – 50 × 32	50	32	25	100	50	26	100	16	35	60

Version: **With adjustable spray nozzle and shim**



VDI-C2

AXIAL HOLDERS FORM C2 - LEFT



Application:
Mainly for external machining.
For face machining.

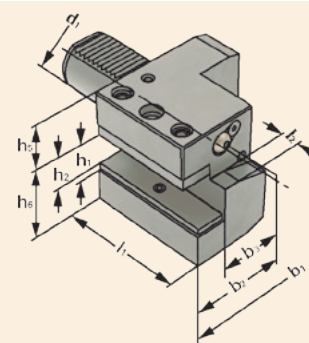

DIN ISO 10889

C2

Order no.	Size	d_1	h_1	h_2	b_1	b_2	b_3	l_1	l_2	h_5	h_6
VDI.30-C2.20	C2 – 30 × 20	30	20	16	76	41	23	70	10	28	38
VDI.40-C2.25	C2 – 40 × 25	40	25	20	90	47,5	25,5	85	12,5	32,5	48
VDI.50-C2.32	C2 – 50 × 32	50	32	25	105	55	30,5	100	16	35	60

Version: **With adjustable spray nozzle and shim**



DIN 69871

ISO 60

MAS 403 BT

DIN 2080

HSK-A

VDI

MORSE



VDI-C3

AXIAL HOLDERS FORM C3 - UPSIDE-DOWN - RIGHT - SHORT



Application:
Mainly for external machining.
For face machining.

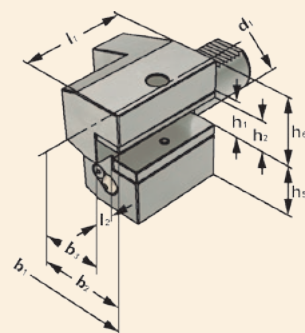

DIN ISO 10889

C3

Order no.	Size	d_1	h_1	h_2	b_1	b_2	b_3	l_1	l_2	h_5	h_6
VDI.30-C3.20	C3 – 30 × 20	30	20	16	70	35	17	70	10	38	35
VDI.40-C3.25	C3 – 40 × 25	40	25	20	85	42,5	21	85	12,5	48	42,5
VDI.50-C3.32	C3 – 50 × 32	50	32	25	100	50	26	100	16	60	50

Version: **With adjustable spray nozzle and shim**



VDI-C4

AXIAL HOLDERS FORM C4 - UPSIDE-DOWN - LEFT - SHORT



Application:
Mainly for external machining.
For face machining.

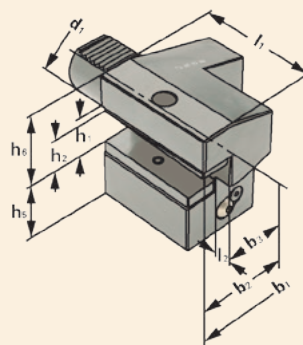

DIN ISO 10889

C4

Order no.	Size	d_1	h_1	h_2	b_1	b_2	b_3	l_1	l_2	h_5	h_6
VDI.30-C4.20	C4 – 30 × 20	30	20	16	76	41	23	70	10	38	35
VDI.40-C4.25	C4 – 40 × 25	40	25	20	90	47,5	25,5	85	12,5	48	42,5
VDI.50-C4.32	C4 – 50 × 32	50	32	25	105	55	30,5	100	16	60	50

Version: **With adjustable spray nozzle and shim**



DIN 69871

ISO 60

MAS 403 BT

DIN 2080

HSK-A

VDI

MORSE



VDI-D1

MULTIPLE SEATS HOLDERS FORM D1



Application:
Mainly for external machining.
For face machining.

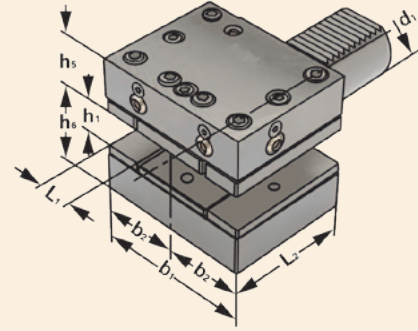

DIN ISO 10889

D1

Order no.	Size	d_1	b_1	L_2	h_1	h_2
VDI.30-D1.20	D1 – 30 × 20 × 76	30	76	60	20	66
VDI.40-D1.25	D1 – 40 × 25 × 90	40	90	72	25	80,5
VDI.50-D1.32	D1 – 50 × 32 × 105	50	105	85	32	95

Version: **With adjustable spray nozzle and shim**



VDI-D2

MULTIPLE SEATS HOLDERS FORM D2 - UPSIDE-DOWN



Application:
Mainly for external machining.
For face machining.

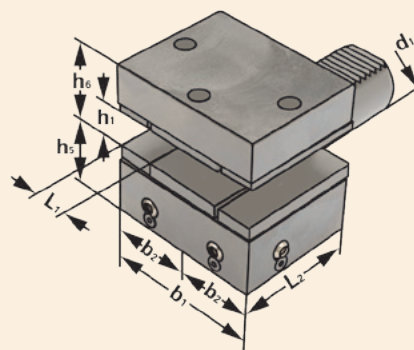

DIN ISO 10889

D2

Order no.	Size	d_1	b_1	L_2	h_1	h_2
VDI.30-D2.20	D2 – 30 x 20 x 76	30	76	60	20	73
VDI.40-D2.25	D2 – 40 x 25 x 90	40	90	72	25	90,5
VDI.50-D2.32	D2 – 50 x 32 x 105	50	105	85	32	110

Version: **With adjustable spray nozzle and shim**



DIN 69871

ISO 60

MAS 403 BT

DIN 2080

HSK-A

VDI

MORSE



VDI-AR

PARTING-OFF HOLDERS FORM AR - RIGHT - ADJUSTABLE HEIGHT



Application:
Mainly for external machining.
For face machining.

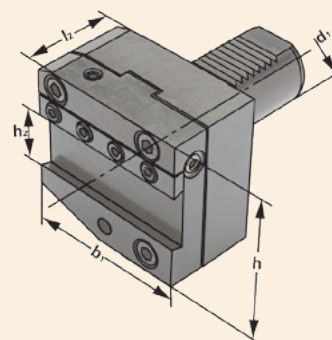

DIN ISO 10889

Order no.	Size	d_1	b_1	h	l_2	h_2
VDI.30-AR.26	AR – 30 × 26	30	70	70	50	26
VDI.40-AR.32	AR – 40 × 32	40	85	78	50	32
VDI.50-AR.32	AR – 50 × 32	50	100	80	50	32

Version: **With adjustable spray nozzle and shim**



250

DIN 69871

ISO 60

MAS 403 BT

DIN 2080

HSK-A

VDI

MORSE



VDI-AL

PARTING-OFF HOLDERS FORM AL - LEFT - ADJUSTABLE HEIGHT



Application:
Mainly for external machining.
For face machining.

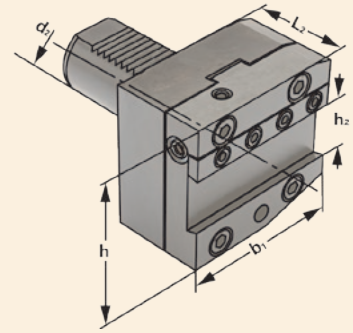

DIN ISO 10889

Order no.	Size	d_1	b_1	h	l_2	h_2
VDI.30-AL.26	AL – 30 × 26	30	70	70	50	26
VDI.40-AL.32	AL – 40 × 32	40	85	78	50	32
VDI.50-AL.32	AL – 50 × 32	50	100	80	50	32

Version: **With adjustable spray nozzle and shim**



DIN 69871

ISO 60

MAS 403 BT

DIN 2080

HSK-A

VDI

MORSE



VDI-E1

HOLDERS FORM E1 FOR DRILLS WITH INDEXABLE INSERTS



Application:
For all solid drills with cylindrical shank according to DIN 6595.

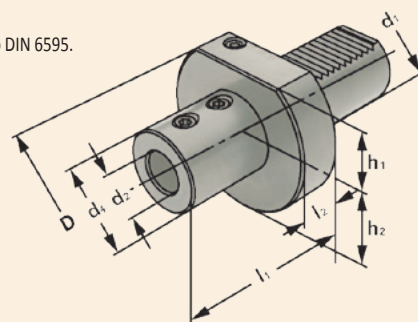

DIN ISO 10889

E1

Order no.	Size	d_1	d_2	d_4	D	h_1	h_2	l_1	l_2
VDI.30-E1.16	E1 – 30 × 16	30	16	36	68	28	30	64	22
VDI.30-E1.20	E1 – 30 × 20	30	20	40	68	28	30	67	22
VDI.30-E1.25	E1 – 30 × 25	30	25	45	68	28	30	71	22
VDI.30-E1.32	E1 – 30 × 32	30	32	52	68	28	30	75	22
VDI.30-E1.40	E1 – 30 × 40	30	40	60	68	28	30	95	22
VDI.40-E1.16	E1 – 40 × 16	40	16	36	83	32,5	–	64	22
VDI.40-E1.20	E1 – 40 × 20	40	20	40	83	32,5	–	67	22
VDI.40-E1.25	E1 – 40 × 25	40	25	45	83	32,5	–	75	22
VDI.40-E1.32	E1 – 40 × 32	40	32	52	83	32,5	–	75	22
VDI.40-E1.40	E1 – 40 × 40	40	40	65	83	32,5	–	90	22
VDI.50-E1.16	E1 – 50 × 16	50	16	40	98	35	–	66	30
VDI.50-E1.20	E1 – 50 × 20	50	20	40	98	35	–	66	30
VDI.50-E1.25	E1 – 50 × 25	50	25	45	98	35	–	80	30
VDI.50-E1.32	E1 – 50 × 32	50	32	52	98	35	–	80	30
VDI.50-E1.40	E1 – 50 × 40	50	40	65	98	35	–	90	30
VDI.50-E1.50	E1 – 50 × 50	50	50	75	98	35	–	100	30

Delivery: **With clamping screws**

DIN 69871

ISO 60

MAS 403 BT

DIN 2080

HSK-A

VDI

MORSE



VDI-E2

HOLDERS FORM E2 FOR BORING BARS



Application:
For internal machining with boring bars.

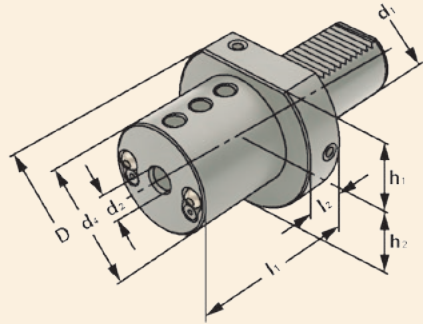

DIN ISO 10889

E2

Order no.	Size	d_1	d_2	D	d_4	h_1	h_2	l_1	l_2
VDI.30-E2.08	E2 – 30 × 08	30	8	68	55	28	30	60	22
VDI.30-E2.10	E2 – 30 × 10	30	10	68	55	28	30	60	22
VDI.30-E2.12	E2 – 30 × 12	30	12	68	55	28	30	60	22
VDI.30-E2.16	E2 – 30 × 16	30	16	68	55	28	30	60	22
VDI.30-E2.20	E2 – 30 × 20	30	20	68	55	28	30	60	22
VDI.30-E2.25	E2 – 30 × 25	30	25	68	55	28	30	60	22
VDI.30-E2.32	E2 – 30 × 32	30	32	68	68	28	30	75	22
VDI.40-E2.08	E2 – 40 × 08	40	8	83	55	32,5	–	75	22
VDI.40-E2.10	E2 – 40 × 10	40	10	83	55	32,5	–	75	22
VDI.40-E2.12	E2 – 40 × 12	40	12	83	55	32,5	–	75	22
VDI.40-E2.16	E2 – 40 × 16	40	16	83	55	32,5	–	75	22
VDI.40-E2.20	E2 – 40 × 20	40	20	83	55	32,5	–	75	22
VDI.40-E2.25	E2 – 40 × 25	40	25	83	55	32,5	–	75	22
VDI.40-E2.32	E2 – 40 × 32	40	32	83	83	32,5	–	75	22
VDI.40-E2.40	E2 – 40 × 40	40	40	83	83	32,5	–	90	22
VDI.50-E2.12	E2 – 50 × 12	50	12	98	68	35	–	90	30
VDI.50-E2.16	E2 – 50 × 16	50	16	98	68	35	–	90	30
VDI.50-E2.20	E2 – 50 × 20	50	20	98	68	35	–	90	30
VDI.50-E2.25	E2 – 50 × 25	50	25	98	68	35	–	90	30
VDI.50-E2.32	E2 – 50 × 32	50	32	98	68	35	–	90	30
VDI.50-E2.40	E2 – 50 × 40	50	40	98	98	35	–	90	30
VDI.50-E2.50	E2 – 50 × 50	50	50	98	98	35	–	100	30

Version: With adjustable spray nozzles

Delivery: With clamping screws



250

249

DIN 69871

ISO 60

MAS 403 BT

DIN 2080

HSK-A

VDI

MORSE



VDI-E3

COLLET CHUCK HOLDERS FORM E3 - OZ COLLET



Application:
For mounting straight-shank tools in collets.

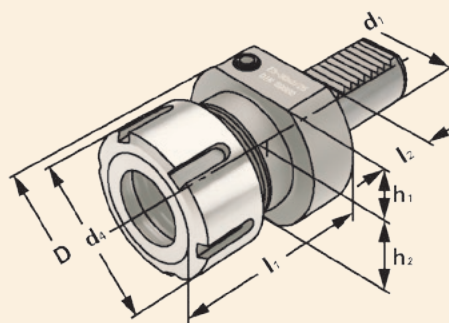

DIN ISO 10889

E3

Order no.	Size	d_1	Range	D	d_2	h_1	h_2	l_1	l_2
VDI.30-E3.OZ16	E3-30×2-16	30	2-16 (OZ 16)	68	43	28	30	57	22
VDI.30-E3.OZ25	E3-30×2-25	30	2-25 (OZ 25)	68	60	28	30	75	22
VDI.40-E3.OZ25	E3-40×2-25	40	2-25 (OZ 25)	83	60	32,5	-	75	22
VDI.40-E3.OZ32	E3-40×3-32	40	3-32 (OZ 32)	83	72	32,5	-	90	22
VDI.50-E3.OZ25	E3-50×2-25	50	2-25 (OZ 25)	98	60	35	-	75	30
VDI.50-E3.OZ32	E3-50×3-32	50	3-32 (OZ 32)	98	72	35	-	90	30

Delivery: **With ball bearing clamping nut**



194 - 199



240



231



231



232 - 234

VDI-E4

COLLET CHUCK HOLDERS FORM E4 - ER COLLET



Application:
For mounting straight-shank tools in collets.

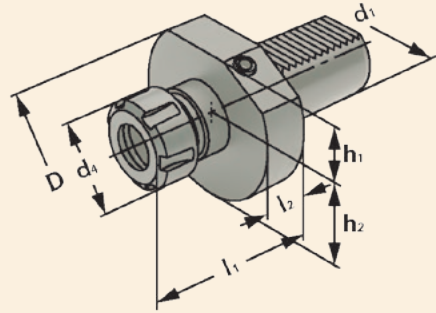

DIN ISO 10889

E4

Order no.	Size	d_1	Range	D	d_4	h_1	h_2	l_1	l_2
VDI.30-E4.ER25	E4 - 30 × 2 - 16	30	2 - 16 (ER 25)	68	42	28	30	57	22
VDI.30-E4.ER32	E4 - 30 × 2 - 20	30	2 - 20 (ER 32)	68	50	28	30	75	22
VDI.30-E4.ER40	E4 - 30 × 3 - 26	30	3 - 26 (ER 40)	68	63	28	30	75	22
VDI.40-E4.ER25	E4 - 40 × 2 - 16	40	2 - 16 (ER 25)	83	42	32,5	-	75	22
VDI.40-E4.ER32	E4 - 40 × 2 - 20	40	2 - 20 (ER 32)	83	50	32,5	-	75	22
VDI.40-E4.ER40	E4 - 40 × 3 - 26	40	3 - 26 (ER 40)	83	63	32,5	-	75	22
VDI.50-E4.ER40	E4 - 50 × 3 - 26	50	3 - 26 (ER 40)	98	63	35	-	75	30

Delivery: **With balanced clamping nut**



DIN 69871

ISO 60

MAS 403 BT

DIN 2080

HSK-A

VDI

MORSE



VDI-F1

HOLDERS FORM F1 FOR MORSE TAPER



Application:
For holding tools with Morse taper shank and tang according to DIN 228-1 form B.

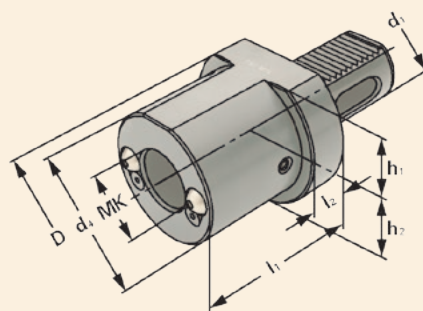

DIN ISO 10889

F1

Order no.	Size	d_1	MK	d_4	D	l_1	l_2	h_1	h_2
VDI.30-F1.MT.1	F1 – 30 × MT 1	30	1	–	68	27	–	28	30
VDI.30-F1.MT.2	F1 – 30 × MT 2	30	2	–	68	27	–	28	30
VDI.30-F1.MT.3	F1 – 30 × MT 3	30	3	58	68	66	22	28	30
VDI.40-F1.MT.2	F1 – 40 × MT 2	40	2	55	83	36	22	32,5	–
VDI.40-F1.MT.3	F1 – 40 × MT 3	40	3	55	83	36	22	32,5	–
VDI.40-F1.MT.4	F1 – 40 × MT 4	40	4	68	83	80	22	32,5	–
VDI.50-F1.MT.2	F1 – 50 × MT 2	50	2	55	98	36	30	35	–
VDI.50-F1.MT.3	F1 – 50 × MT 3	50	3	58	98	36	30	35	–
VDI.50-F1.MT.4	F1 – 50 × MT 4	50	4	68	98	50	30	35	–
VDI.50-F1.MT.5	F1 – 50 × MT 5	50	5	75	98	168	30	35	–

Version: **With adjustable spray nozzles**



VDI-HC

HYDRAULIC CHUCKS



Application:

For mounting straight-shank tools acc. DIN 1835 form A+B+E and DIN 6535 form HA+HB+HE (for dia. 20 mm or 32 mm reduction sleeve can be used).

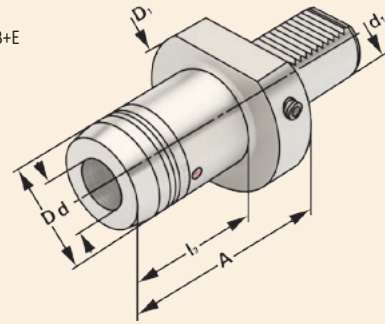

DIN ISO 10889

Order no.	Size	d_1	d	D	A	l_3	D_1
VDI.30-HC.06.49	30 - 06	30	6	26	49	33	68
VDI.30-HC.08.49	30 - 08	30	8	28	49	33	68
VDI.30-HC.10.49	30 - 10	30	10	30	49	33	68
VDI.30-HC.12.54	30 - 12	30	12	32	54	38	68
VDI.30-HC.14.54	30 - 14	30	14	34	54	38	68
VDI.30-HC.16.89	30 - 16	30	16	38	89	73	68
VDI.30-HC.18.89	30 - 18	30	18	40	89	73	68
VDI.30-HC.20.89	30 - 20	30	20	42	89	73	68
VDI.30-HC.25.94	30 - 25	30	25	50	94	78	68
VDI.30-HC.32.94	30 - 32	30	32	60	94	78	68
VDI.40-HC.06.55	40 - 06	40	6	26	55	33	83
VDI.40-HC.08.55	40 - 08	40	8	28	55	33	83
VDI.40-HC.10.55	40 - 10	40	10	30	55	33	83
VDI.40-HC.12.60	40 - 12	40	12	32	60	38	83
VDI.40-HC.14.60	40 - 14	40	14	34	60	38	83
VDI.40-HC.16.95	40 - 16	40	16	38	95	73	83
VDI.40-HC.18.95	40 - 18	40	18	40	95	73	83
VDI.40-HC.20.95	40 - 20	40	20	42	95	73	83
VDI.40-HC.25.95	40 - 25	40	25	50	95	73	83
VDI.40-HC.32.95	40 - 32	40	32	60	95	73	83
VDI.50-HC.06.55	50 - 06	50	6	26	55	33	98
VDI.50-HC.08.55	50 - 08	50	8	28	55	33	98
VDI.50-HC.10.55	50 - 10	50	10	30	55	33	98
VDI.50-HC.12.60	50 - 12	50	12	32	60	38	98
VDI.50-HC.14.60	50 - 14	50	14	34	60	38	98
VDI.50-HC.16.95	50 - 16	50	16	38	95	65	98
VDI.50-HC.18.95	50 - 18	50	18	40	95	65	98
VDI.50-HC.20.95	50 - 20	50	20	42	95	65	98
VDI.50-HC.25.95	50 - 25	50	25	50	95	65	98
VDI.50-HC.32.95	50 - 32	50	32	60	95	65	98



Delivery: With wrench

DIN 69871

ISO 60

MAS 403 BT

DIN 2080

HSK-A

VDI

MORSE



VDI-Z2-S

PROTECTION PLUGS FORM Z2 - STEEL



Application:
For sealing the spindle of the turret.

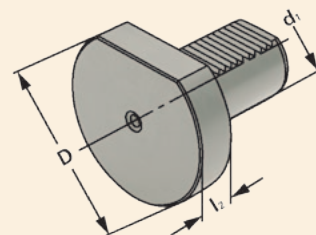

DIN ISO 10889

Z2

Order no.	Size	d_1	D	l_2
VDI.30-Z2.S	Z2 – 30 × 16	30	68	16
VDI.40-Z2.S	Z2 – 40 × 20	40	83	20
VDI.50-Z2.S	Z2 – 50 × 20	50	98	20

DIN 69871

ISO 60

MAS 403 BT

DIN 2080

HSK-A

VDI

MORSE



VDI-Z2-P

PROTECTION PLUGS FORM Z2 - PLASTIC



Application:
For sealing the spindle of the turret.

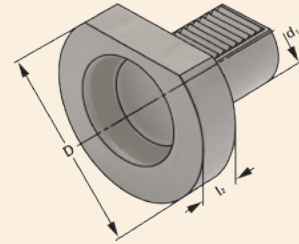

DIN ISO 10889

Z2

Order no.	Size	d_1	D	l_2
VDI.30-Z2.P	Z2 – 30 × 16	30	68	16
VDI.40-Z2.P	Z2 – 40 × 20	40	83	20
VDI.50-Z2.P	Z2 – 50 × 20	50	98	20

DIN 69871

ISO 60

MAS 403 BT

DIN 2080

HSK-A

VDI

MORSE



VDI-DC

DRILL CHUCK HOLDERS



Application:
For mounting tools with straight shank.

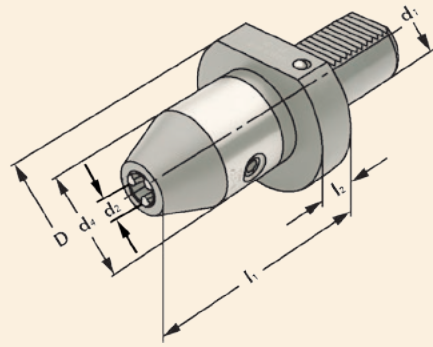

DIN ISO 10889

Order no.	d_1	d_2 Range	d_4	D	l_1	l_2
VDI.30-DC.13.093	30	1 – 13	50	68	93	22
VDI.30-DC.16.098	30	2,5 – 16	50	68	98	22
VDI.40-DC.13.093	40	1 – 13	50	83	93	22
VDI.40-DC.16.098	40	2,5 – 16	50	83	98	22
VDI.50-DC.13.101	50	1 – 13	50	98	101	30
VDI.50-DC.16.106	50	2,5 – 16	50	98	106	30

Note: High precision and accurate concentricity of ≤ 0.03 mm. Secure gripping of the tool through mechanical amplification of the clamping force. No automatic slackening of the clamping force while machining with either clockwise or counter clockwise rotation. Clamping and releasing effected by means of an Allen wrench.

Delivery: **With wrench**

DIN 69871

ISO 60

MAS 403 BT

DIN 2080

HSK-A

VDI

MORSE



VDI-DC-C

DRILL CHUCK HOLDERS WITH COOLANT NOZZLES



Application:
For mounting tools with straight shanks.

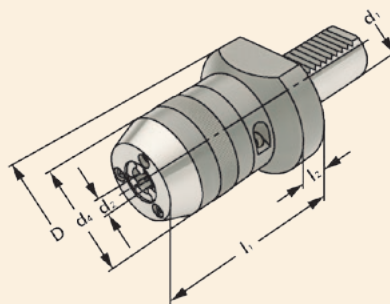

DIN ISO 10889

Order no.	d_1	d_2 Range	d_4	D	l_1	l_2
VDI.30-DC.13.087.C	30	1 – 13	50	68	87	22
VDI.30-DC.16.093.C	30	3 – 16	55	68	93	22
VDI.40-DC.13.088.C	40	1 – 13	50	83	88	22
VDI.40-DC.16.093.C	40	3 – 16	55	83	93	22
VDI.50-DC.16.102.C	50	2,5 – 16	55	98	102	

Note: High precision and accurate concentricity of ≤ 0.03 mm. Secure gripping of the tool through mechanical amplification of the clamping force. No automatic slackening of the clamping force while machining with either clockwise or counter clockwise rotation. Clamping and releasing effected by means of an Allen wrench.

Delivery: With wrench

DIN 69871

ISO 60

MAS 403 BT

DIN 2080

HSK-A

VDI

MORSE



VDI-QTCC

QUICK-CHANGE TAPPING CHUCKS WITH COMPENSATION



Application:
For the chucking of Quick change taps for threading taps.

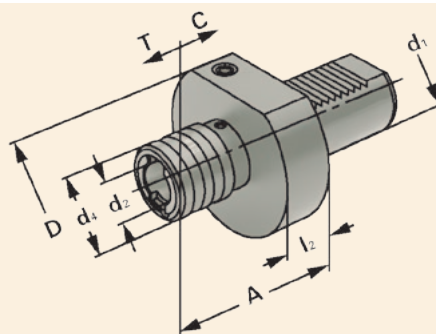

DIN ISO 10889

Order no.	d_1	Range	Size	D	A	d_4	d_2	C	T
VDI.30-QTCC.M3.M14	30	M3 – M14	1	68	55	38	19	7	7
VDI.30-QTCC.M5.M22	30	M5 – M22	2	68	77	54	31	12	12
VDI.40-QTCC.M3.M14	40	M3 – M14	1	83	55	38	19	7	7
VDI.40-QTCC.M5.M22	40	M5 – M22	2	83	77	54	31	12	12
VDI.50-QTCC.M3.M14	50	M3 – M14	1	98	55	38	19	7	7
VDI.50-QTCC.M5.M22	50	M5 – M22	2	98	77	54	31	12	12



DIN 69871

ISO 60

MAS 403 BT

DIN 2080

HSK-A

VDI

MORSE



VDI-QTCW

QUICK-CHANGE TAPPING CHUCKS WITHOUT COMPENSATION



Application:
On machining centres with synchronised spindles. For the chucking of Quick change taps for threading taps.

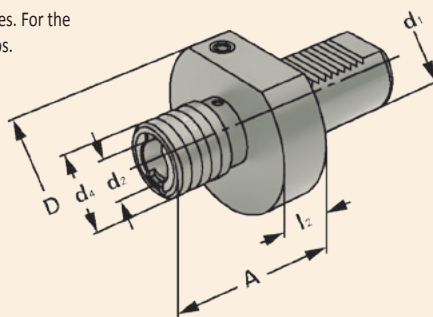

DIN ISO 10889

Order no.	d_1	Range	Size	D	A	d_4	d_2
VDI.30-QTCW.M3.M14	30	M3 – M14	1	68	55	34	19
VDI.30-QTCW.M5.M22	30	M5 – M22	2	68	77	50	31
VDI.40-QTCW.M3.M14	40	M3 – M14	1	83	55	38	19
VDI.40-QTCW.M5.M22	40	M5 – M22	2	83	77	52	31



DIN 69871

ISO 60

MAS 403 BT

DIN 2080

HSK-A

VDI

MORSE



VDI-A1

BLANKS FORM A1



Application:
For the manufacturing of special tools.

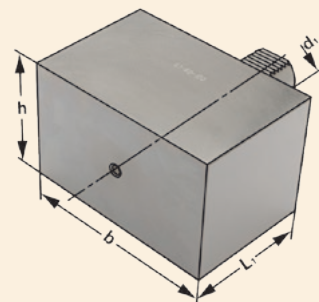

DIN ISO 10889

A1

Order no.	Size	d_1	L_1	h	b
VDI.30-A1.130.076.085	A1 - 30 - 130 - 76 - 85	30	85	76	130
VDI.40-A1.151.096.100	A1 - 40 - 151 - 96 - 100	40	100	96	151
VDI.50-A1.160.120.125	A1 - 50 - 160 - 120 - 125	50	125	120	160

DIN 69871

ISO 60

MAS 403 BT

DIN 2080

HSK-A

VDI

MORSE



VDI-A2

BLANKS FORM A2



Application:
For the manufacturing of special tools.

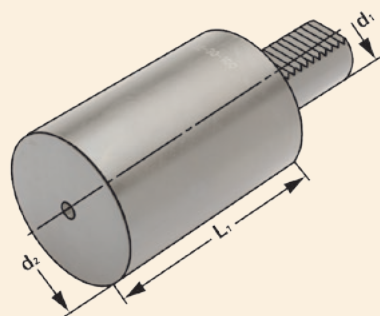

DIN ISO 10889

A2

Order no.	Size	d_1	d_2	L_1
VDI.30-A2.068.100	A2 - 30 - 68 - 100	30	68	100
VDI.30-A2.068.240	A2 - 30 - 68 - 240	30	68	240
VDI.40-A2.083.120	A2 - 40 - 83 - 120	40	83	120
VDI.40-A2.083.320	A2 - 40 - 83 - 320	40	83	320
VDI.50-A2.098.135	A2 - 50 - 98 - 135	50	98	135
VDI.50-A2.098.400	A2 - 50 - 98 - 400	50	98	400

DIN 69871

ISO 60

MAS 403 BT

DIN 2080

HSK-A

VDI

MORSE



VDI-TA

TEST ARBORS



Application:
For the inspection of machine tools.

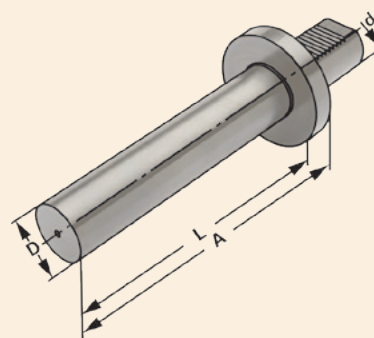

DIN ISO 10889

Order no.	Size	d_1	D	A	L
VDI.30.TA.40.200	30 - 40 - 200	30	40	200	178
VDI.40.TA.40.200	40 - 40 - 200	40	40	200	178
VDI.50.TA.40.200	50 - 40 - 200	50	40	200	170

DIN 69871

ISO 60

MAS 403 BT

DIN 2080

HSK-A

VDI

MORSE



MORSE



MORSE toolholders MT (DIN 228-1 A)

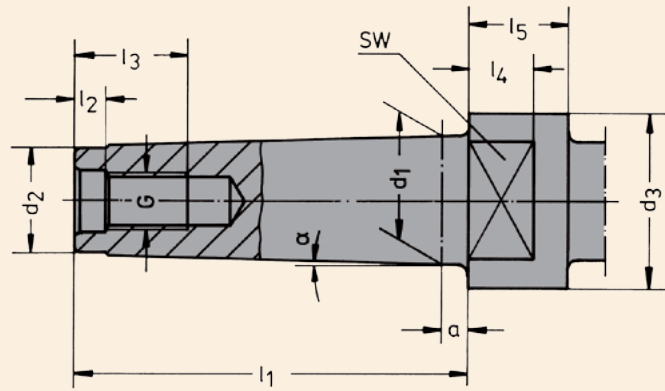

MT	α	G	a	d_1	d_2 max.	d_3	SW d^9	l_1	l_2	l_3	l_4	l_5
1	1°25'43"	M6	3,5	12,065	9	-	-	-	4	16	-	-
2	1°25'50"	M10	5	17,780	14	-	-	-	5	24	-	-
3	1°26'16"	M12	5	23,825	19	36	24	86	5,5	24	12	18
4	1°29'15"	M16	6,5	31,267	25	43	32	109	8,2	32	15	23
5	1°30'26"	M20	6,5	44,399	35,7	60	45	136	10	40	18	28
6	1°29'36"	M24	8	63,348	51	84	65	190	11,5	47	25	39

Material: **Alloyed case hardened steel, tensile strength in the core of min. 1200 N/mm²**
Case hardened HRC 60 ± 2 (HV 700 ± 50), hardening depth 0.8 mm ± 0.2 mm,
black-finished and precisely grinded.

DIN 69871

ISO 60

MAS 403 BT

DIN 2080

HSK-A

VDI

MORSE



MORSE-CC-ER



166

MORSE-FMH2



167

MORSE-QTCC



168

MORSE-RED-MT



169

MORSE-DC



170

DIN 69871

ISO 60

MAS 403 BT

DIN 2080

HSK-A

VDI

MORSE



MORSE-CC-ER

COLLET CHUCKS - ER



Application:
For mounting straight-shank tools in collets.

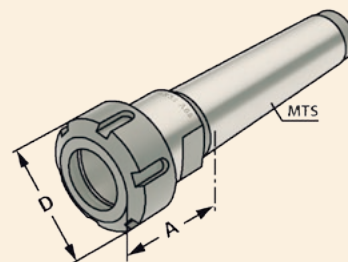

DIN 228-1 A

$\nabla \leq 0,008$

G6,3
15.000 min⁻¹

Order no.	MTS	Range	A	D
MORSE.MTS.2-CC.ER16.045	2	1 – 10 (ER 16)	45	32
MORSE.MTS.2-CC.ER25.050	2	2 – 16 (ER 25)	50	42
MORSE.MTS.3-CC.ER25.056	3	2 – 16 (ER 25)	56	42
MORSE.MTS.3-CC.ER32.070	3	2 – 20 (ER 32)	70	50
MORSE.MTS.4-CC.ER25.063	4	2 – 16 (ER 25)	63	42
MORSE.MTS.4-CC.ER32.065	4	2 – 20 (ER 32)	65	50
MORSE.MTS.5-CC.ER40.086	5	3 – 26 (ER 40)	86	63

Delivery: **With balanced clamping nut**



DIN 69871

ISO 60

MAS 403 BT

DIN 2080

HSK-A

VDI

MORSE



MORSE-FMH2

COMBI SHELL MILL HOLDERS



Application:
For mounting milling cutters with transverse or longitudinal groove.

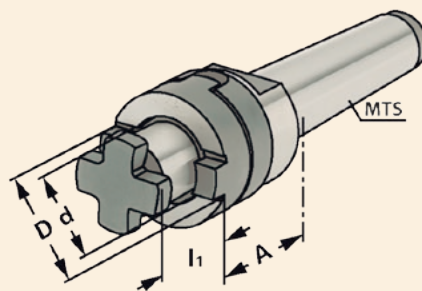

DIN 228-1 A

$\nabla \leq 0,008$

Order no.	MTS	d	A	l ₁	D
MORSE.MTS.2-FMH2.16.043	2	16	43	17	32
MORSE.MTS.2-FMH2.22.043	2	22	43	19	40
MORSE.MTS.3-FMH2.16.048	3	16	48	17	32
MORSE.MTS.3-FMH2.22.048	3	22	48	19	40
MORSE.MTS.3-FMH2.27.048	3	27	48	21	48
MORSE.MTS.3-FMH2.32.048	3	32	48	24	58
MORSE.MTS.4-FMH2.16.055	4	16	55	17	32
MORSE.MTS.4-FMH2.22.055	4	22	55	19	40
MORSE.MTS.4-FMH2.27.055	4	27	55	21	48
MORSE.MTS.4-FMH2.32.055	4	32	55	24	58
MORSE.MTS.5-FMH2.22.075	5	22	75	19	40
MORSE.MTS.5-FMH2.27.075	5	27	75	21	48
MORSE.MTS.5-FMH2.32.075	5	32	75	24	58
MORSE.MTS.5-FMH2.40.075	5	40	75	27	70

Delivery: With tightening bolt, driving ring and feather key



DIN 69871

ISO 60

MAS 403 BT

DIN 2080

HSK-A

VDI

MORSE



MORSE-QTCC

QUICK-CHANGE TAPPING CHUCKS WITH COMPENSATION



Application:
For the chucking of Quick change taps for threading taps.

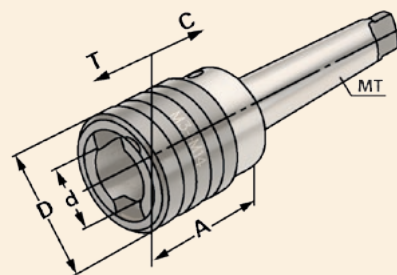

DIN 228-1 B

Order no.	MT	Range	Size	A	D	d	T	C
MORSE.MT.2-QTCC.M3.M14	2	M3 – M14	1	46	36	19	7	7
MORSE.MT.3-QTCC.M3.M14	3	M3 – M14	1	46	36	19	7	7
MORSE.MT.3-QTCC.M5.M22	3	M5 – M22	2	70	53	31	12	12
MORSE.MT.4-QTCC.M3.M14	4	M3 – M14	1	46	36	19	7	7
MORSE.MT.4-QTCC.M5.M22	4	M5 – M22	2	70	53	31	12	12
MORSE.MT.4-QTCC.M14.M36	4	M14 – M36	3	123	78	48	17,5	17,5



MORSE-RED-MT

REDUCTIONS FOR MORSE TAPER



Application:
For mounting tools with Morse taper shanks.

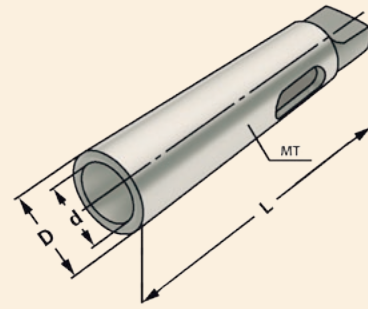

DIN 228-1 B

$\nabla \leq 0,01$

Order no.	D	d	L
MORSE.MT.2-RED.MT.1.092	MK 2	MK 1	92
MORSE.MT.3-RED.MT.2.098	MK 3	MK 2	98
MORSE.MT.4-RED.MT.2.124	MK 4	MK 2	124
MORSE.MT.4-RED.MT.3.132	MK 4	MK 3	132
MORSE.MT.5-RED.MT.3.156	MK 5	MK 3	156
MORSE.MT.5-RED.MT.4.171	MK 5	MK 4	171
MORSE.MT.6-RED.MT.4.218	MK 6	MK 4	218
MORSE.MT.6-RED.MT.5.218	MK 6	MK 5	218

Version: Entirely hardened and grinded on the inside and outside



242

DIN 69871

ISO 60

MAS 403 BT

DIN 2080

HSK-A

VDI

MORSE



MORSE-DC

DRILL CHUCK HOLDERS



Application:
For mounting tools with straight shanks.

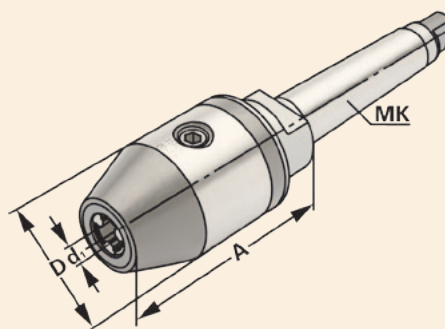

DIN 228-1 B

$\nearrow \leq 0,03$

Order no.	MT	d Range	A	D
MORSE.MT.3-DC.13.098	3	1 – 13	98	50
MORSE.MT.3-DC.16.103	3	2,5 – 16	103	50
MORSE.MT.4-DC.13.100	4	1 – 13	100	50
MORSE.MT.4-DC.16.105	4	2,5 – 16	105	50

Note: High precision and accurate concentricity of ≤ 0.03 mm. Secure gripping of the tool through mechanical amplification of the clamping force. No automatic slackening of the clamping force while machining with either clockwise or counter clockwise rotation or on spindle stop. Clamping and releasing effected by means of an Allen wrench.

Delivery: **With wrench**

- DIN 69871
- ISO 60
- MAS 403 BT
- DIN 2080
- HSK-A
- VDI
- MORSE
-
-
-
-

ADAPTORS

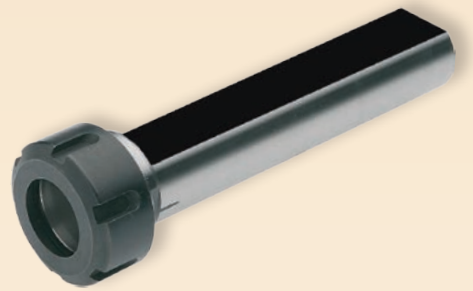

AC-CC-ER



173

ACF-CC-ER



174

ACF-CC-ER-HX



175

ACF-CCM-ER



176

ACF-CCM-ER



177

ACF-CCM-ER-D



177

AC-HC



178

AC-SC



179

AW-DC



180

AW-QTCC



181

AW-QTCW



182

AW-RED-W



183

DIN 69871

ISO 60

MAS 403 BT

DIN 2080

HSK-A

VDI

MORSE



AC-CC-ER

ADAPTORS WITH CYLINDRICAL SHANK - COLLET CHUCKS - ER



Application:
For mounting straight-shank tools in collets.

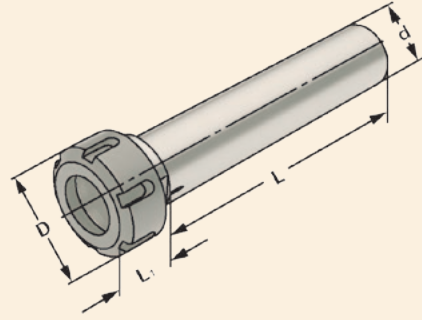

Order no.	dH6	Range	L	L ₁	D
AC.16-CC.ER16.150	16	1 – 10 (ER 16)	150	30	32
AC.20-CC.ER25.150	20	1 – 16 (ER 25)	150	40	42
AC.32-CC.ER32.150	32	2 – 20 (ER 32)	150	35	50

Delivery: With clamping nuts

Adaptors with internal coolant hole



DIN 69871

ISO 60

MAS 403 BT

DIN 2080

HSK-A

VDI

MORSE



ACF-CC-ER

ADAPTORS WITH CYLINDRICAL SHANK AND FLAT CLAMPING SURFACE - COLLET CHUCKS - ER



Application:
For mounting straight-shank tools in collets.

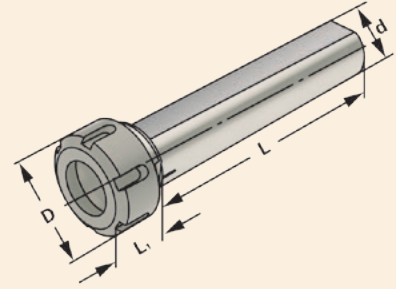

Order no.	dH6	Range	L	L ₁	D
ACF.16-CC.ER16.150	16	1 – 10 (ER 16)	150	30	32
ACF.20-CC.ER25.150	20	1 – 16 (ER 25)	150	40	42
ACF.32-CC.ER32.150	32	2 – 20 (ER 32)	150	35	50

Delivery: **With clamping nuts**

Adaptors with internal coolant hole



ACF-CC-ER-HX

ADAPTORS WITH CYLINDRICAL SHANK AND FLAT CLAMPING SURFACE WITH HEXAGONAL NUT - COLLET CHUCKS - ER



Application:
For mounting straight-shank tools in collets.

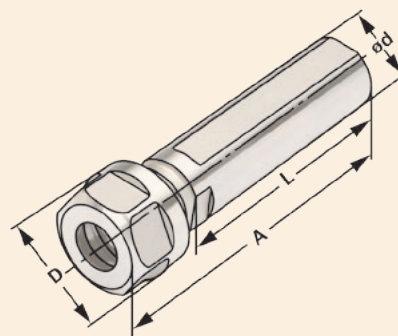

Order no.	Range	dH6	D	L	A
ACF.20-CC.ER11.50.HX	1 – 07 (ER 11)	20	19	50	67,5
ACF.20-CC.ER11.70.HX	1 – 07 (ER 11)	20	19	70	87,5
ACF.20-CC.ER16.70.HX	1 – 10 (ER 16)	20	28	70	96,0

Hexagonal clamping nut

Adaptors with internal coolant hole



DIN 69871
 ISO 60
 MAS 403 BT
 DIN 2080
 HSK-A
 VDI
 MORSE

ACF-CCM-ER

ADAPTORS WITH CYLINDRICAL SHANK AND FLAT CLAMPING SURFACE - MINI COLLET CHUCK - ER



Application:
For mounting straight-shank tools in collets.

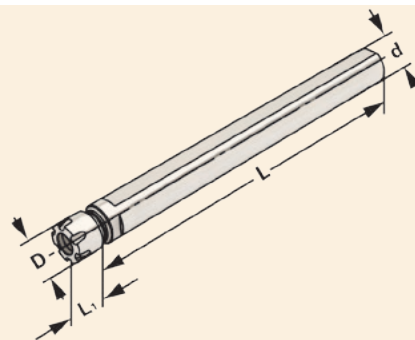



Order no.	dH6	Range	L	L ₁	D
ACF.16-CCM.ER11.150	16	1 – 07 (ER 11)	150	20	16
ACF.20-CCM.ER16.150	20	1 – 10 (ER 16)	150	30	22

Delivery: **With clamping nuts**

Adaptors with internal coolant hole



ACF-CCM-ER

ADAPTORS WITH CYLINDRICAL SHANK AND FLAT CLAMPING SURFACE - MINI COLLET CHUCK - ER



Application:
For mounting straight-shank tools in collets.

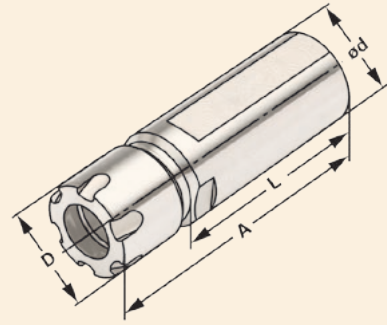

Form AD $\nabla \leq 0,003$

Order no.	Range	dH6	D	L	A
ACF.20-CCM.ER16.50	1 – 10 (ER 16)	20	22	50	76,5



With mini nut

Adaptors with internal coolant hole

ACF-CCM-ER-D

ADAPTORS WITH CYLINDRICAL SHANK AND FLAT CLAMPING SURFACE - MINI COLLET CHUCK - ER - DOUBLE



Application:
For mounting straight-shank tools in collets.

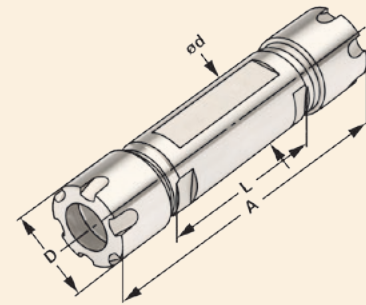

Form AD $\nabla \leq 0,003$

Order no.	Range	dH6	D	L	A
ACF.20-CCM.ER16.70.D	1 – 10 (ER 16)	20	22	70	123



With mini nut

Adaptors with internal coolant hole

DIN 69871

ISO 60

MAS 403 BT

DIN 2080

HSK-A

VDI

MORSE



AC-HC

ADAPTORS WITH CYLINDRICAL SHANK - HYDRAULIC CHUCKS



Application:

For mounting straight-shank tools acc. DIN 1835 form A+B+E and DIN 6535 form HA+HB+HE (smaller than dia. 20 mm only with reduction sleeve).

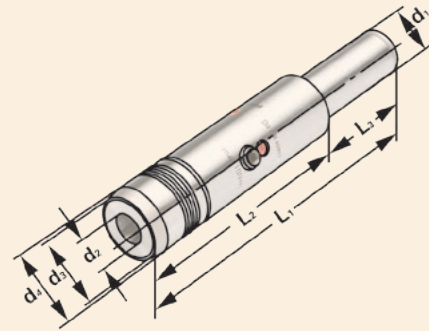

Form A

$\nabla \leq 0,003$

Order no.	d_1	d_2	d_3	d_4	l_1	l_2	l_3
AC.12-HC.12.100	12	12	21	25	146	100	46
AC.20-HC.12.100	20	12	21	25	150	100	50
AC.20-HC.16.100	20	16	25	28	150	100	50
AC.20-HC.20.100	20	20	30	32	150	100	50
AC.32-HC.12.140	32	12	21	25	200	140	60
AC.32-HC.16.140	32	16	25	28	200	140	60
AC.32-HC.20.140	32	20	30	32	200	140	60

Delivery: With wrench

Adaptors without internal coolant hole



AC-SC

ADAPTORS WITH CYLINDRICAL SHANK - SHRINK FIT HOLDERS



Application:
For mounting straight-shank tools.

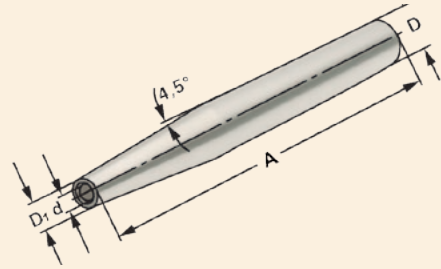

Form AD $\nabla \leq 0,003$

Order no.	D	d	D ₁	A	l ₁	l ₂
AC.20-SC.03.150	20	3	10	150	15	5
AC.20-SC.04.150	20	4	10	150	20	5
AC.20-SC.05.150	20	5	10	150	20	5
AC.20-SC.06.150	20	6	10	150	36	10
AC.20-SC.08.150	20	8	12	150	36	10
AC.20-SC.10.150	20	10	14	150	42	10
AC.20-SC.12.150	20	12	16	150	47	10

For Ø 3, 4 and 5 mm only solid carbide tool shanks must be used!

Note: Toolholders suitable for induction-, contact- and hot air shrink units.
Ø 3, 4, 5 with h4-tolerance and Ø 6 – Ø 32 with h6-tolerance

l₁ = max. clamping depth

l₂ = max. length adjustment range

Adaptors with internal coolant hole

DIN 69871

ISO 60

MAS 403 BT

DIN 2080

HSK-A

VDI

MORSE



AW-DC

ADAPTORS WITH WELDON SHANK - DRILL CHUCK HOLDERS



Application:
For mounting tools with straight shanks.

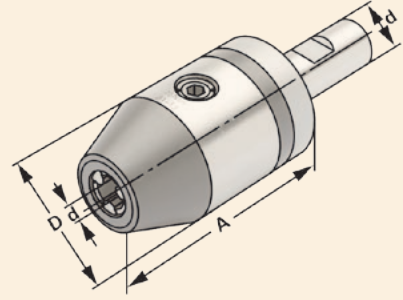

Form A

$\nearrow \leq 0,030$

Order no.	d	d ₁ Range	L	D
AW.20-DC.13.143	20	1 – 13	143	50
AW.20-DC.16.148	20	2,5 – 16	148	50

Note: High precision and accurate concentricity of ≤ 0.03 mm. Secure gripping of the tool through mechanical amplification of the clamping force. No automatic slackening of the clamping force while machining with either clockwise or counter clockwise rotation or on spindle stop. Clamping and releasing effected by means of an Allen wrench.

Delivery: **With wrench**

Adaptors without internal coolant hole

DIN 69871

ISO 60

MAS 403 BT

DIN 2080

HSK-A

VDI

MORSE



AW-QTCC

ADAPTORS WITH WELDON SHANK - QUICK-CHANGE TAPPING CHUCKS WITH COMPENSATION



Application:
For the chucking of Quick change taps for threading taps.

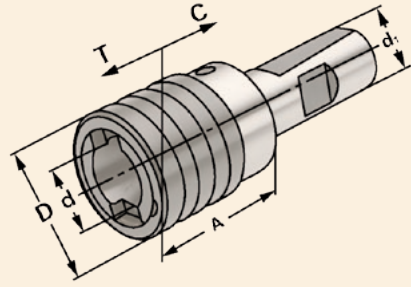

Order no.	d_1	Range	Size	A	D	d	T	C
AW.20-QTCC.M3.M14	20	M3 – M14	1	44	36	19	7	7
AW.20-QTCC.M5.M22	20	M5 – M22	2	73	53	31	12	12

Note: On machining centres without synchronised spindles.

Version: with flat according to DIN 1835 form B (Weldon) and inclined flat according to DIN 1835 form E (Whistle Notch).

Adaptors without internal coolant hole



DIN 69871

ISO 60

MAS 403 BT

DIN 2080

HSK-A

VDI

MORSE



AW-QTCW

ADAPTORS WITH WELDON SHANK - QUICK-CHANGE TAPPING CHUCKS WITHOUT COMPENSATION



Application:

For machines with rigid tapping.
For safe clamping of taps in end mill holders according to DIN 1835 B.

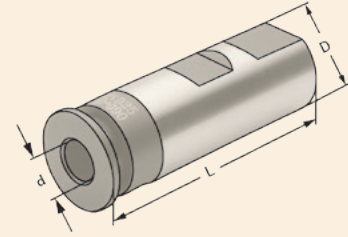

Order no.	D	d Shaft	Square	L
AW.16-QTCW.035.027	16	3,5	2,7	56,0
AW.16-QTCW.040.030	16	4,0	3,0	56,0
AW.16-QTCW.045.034	16	4,5	3,4	56,0
AW.16-QTCW.060.049	16	6,0	4,9	56,0
AW.20-QTCW.045.034	20	4,5	3,4	58,0
AW.20-QTCW.060.049	20	6,0	4,9	58,0
AW.20-QTCW.070.055	20	7,0	5,5	58,0
AW.20-QTCW.080.062	20	8,0	6,2	58,0
AW.20-QTCW.090.070	20	9,0	7,0	58,0
AW.20-QTCW.100.080	20	10,0	8,0	58,0
AW.25-QTCW.045.034	25	4,5	3,4	66,0
AW.25-QTCW.060.049	25	6,0	4,9	66,0
AW.25-QTCW.070.055	25	7,0	5,5	66,0
AW.25-QTCW.080.062	25	8,0	6,2	66,0
AW.25-QTCW.090.070	25	9,0	7,0	66,0
AW.25-QTCW.100.080	25	10,0	8,0	66,0
AW.25-QTCW.110.090	25	11,0	9,0	66,0
AW.25-QTCW.120.090	25	12,0	9,0	66,0
AW.32-QTCW.060.049	32	6,0	4,9	70,0
AW.32-QTCW.070.055	32	7,0	5,5	70,0
AW.32-QTCW.080.062	32	8,0	6,2	70,0
AW.32-QTCW.090.070	32	9,0	7,0	70,0
AW.32-QTCW.100.080	32	10,0	8,0	70,0
AW.32-QTCW.110.090	32	11,0	9,0	70,0
AW.32-QTCW.120.090	32	12,0	9,0	70,0
AW.32-QTCW.140.110	32	14,0	11,0	70,0
AW.32-QTCW.160.120	32	16,0	12,0	70,0
AW.32-QTCW.180.145	32	18,0	14,5	70,0

Adaptors without internal coolant hole

DIN 69871

ISO 60

MAS 403 BT

DIN 2080

HSK-A

VDI

MORSE



AW-RED-W

ADAPTORS WITH WELDON SHANK - REDUCTIONS FOR WELDON



Application:
For mounting straight-shank tools according to DIN 1835 form B+E.

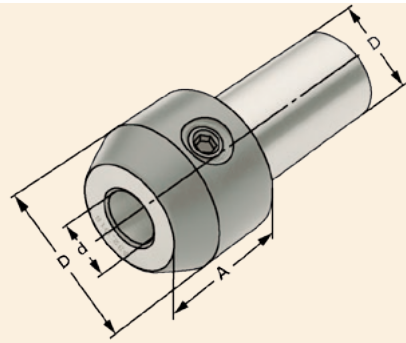

Order no.	D_{h6}	dH4	D_1	A
AW.20-RED.W.06.030	20	6	25	30
AW.20-RED.W.08.030	20	8	28	30
AW.20-RED.W.10.030	20	10	35	30
AW.20-RED.W.12.035	20	12	42	35
AW.32-RED.W.06.030	32	6	25	30
AW.32-RED.W.08.030	32	8	28	30
AW.32-RED.W.10.030	32	10	35	30
AW.32-RED.W.12.035	32	12	42	35
AW.32-RED.W.14.035	32	14	44	35
AW.32-RED.W.16.038	32	16	48	38
AW.32-RED.W.18.038	32	18	50	38
AW.32-RED.W.20.040	32	20	52	40

Delivery: With clamping screw

Adaptors with internal coolant hole

DIN 69871

ISO 60

MAS 403 BT

DIN 2080

HSK-A

VDI

MORSE



SPARE PARTS

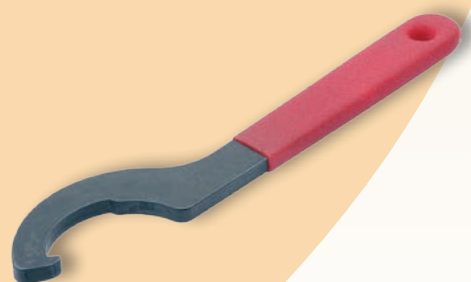
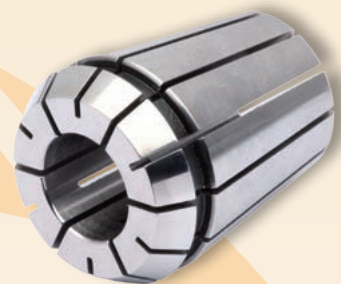

PS-69872 / 7388



190 - 191

PS-BT / BT-C-S



192 - 193

PS-2080-C



193

OZ-C



194 - 195

OZ-C-P



196 - 197

OZ-C-SET-WP



198

OZ-C-SET-WB



198

OZ-C-SET-P-WP



199

OZ-C-SET-P-WB



199

ER-C



200 - 201

ER-C-P



202 - 203

ER-C-S



204 - 205

ER-C-SC4



206 - 207

ER-T



208 - 209

ER-T-SC4



210 - 211

ER-C-SET-WP



212

ER-C-SET-WB



212

ER-C-SET-P-WP



213

ER-C-SET-P-WB



213

ER-C-SET-S-WP



214

ER-C-SET-S-WB



214

DIN 69871

ISO 60

MAS 403 BT

DIN 2080

HSK-A

VDI

MORSE



ER-C-SET-SC4-WP



215

ER-C-SET-SC4-WB



215

ER-T-SET-WP



216

ER-T-SET-WB



217

ER-T-SET-SC4-WP



218

ER-T-SET-SC4-WB



219

HC-C



220

HC-C-S



221

QTCW



222 - 224

QTCC



225 - 227

QTCR



228

HKS-C



229

HKS-C-S



230

N-OZ



231

N-OZ-SR



231

SR-OZ



232 - 234

N-ER-M



235

N-ER



235

N-ER-SR



236

N-ER-SR-SN



236

SR-ER



237 - 239

DIN 69871

ISO 60

MAS 403 BT

DIN 2080

HSK-A

VDI

MORSE



K-HKS



240

K-OZ



240

K-ER



241

K-ER-M



241

K-FMH



242

E-MORSE



242

E-HKS



243

S-FMH



243

S-FMH-C



244

S-W



245

F-FMH2



245

DR-FMH2



246

DS-FMH4



247

S-DS-FMH4



247

CT-HSK-A



248

K-CT-HSK-A



248

VDI-RS-E2

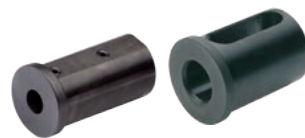

249

VDI-SHIMS



250

VDI-NOZZ



250

TW



251

AB-A360



252

DIN 69871

ISO 60

MAS 403 BT

DIN 2080

HSK-A

VDI

MORSE



AB-S90



 252

DIN 69871

ISO 60

MAS 403 BT

DIN 2080

HSK-A

VDI

MORSE



PS-69872

PULL STUDS DIN 69872

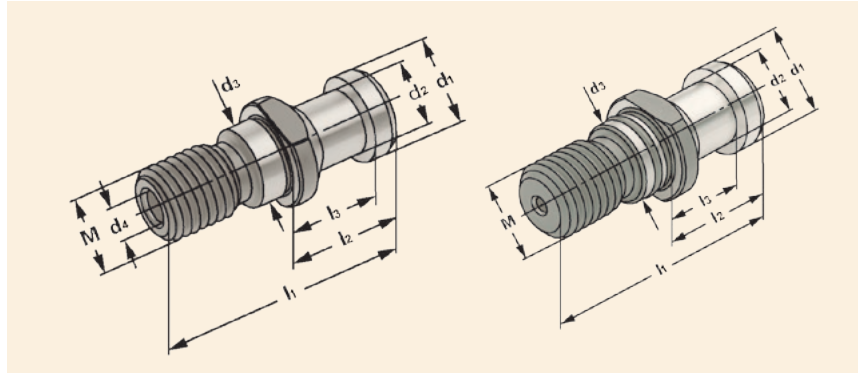

Order no.	M	l_1	l_2	l_3	d_1	d_2	d_3	d_4
PS.69872.30.C	M12	44	24	19	13	9	13	3,0
PS.69872.40.C	M16	54	26	20	19	14	17	7,0
PS.69872.50.C	M24	74	34	25	28	21	25	11,5

Form C (with drill through, without O-ring) DIN 69872 A

PS.69872.40.C.S	M16	54	26	20	19	14	17	7,0
PS.69872.50.C.S	M24	74	34	25	28	21	25	11,5

Form C.S (with drill through, incl. O-ring) DIN 69872 A

PS.69872.40.S	M16	54	26	20	19	14	17	-
PS.69872.50.S	M24	74	34	25	28	21	25	-

Form S (sealed, without drill through, incl. O-ring)

- DIN 69871
- ISO 60
- MAS 403 BT
- DIN 2080
- HSK-A
- VDI
- MORSE
-
-
-
-

PS-7388

PULL STUDS DIN 7388

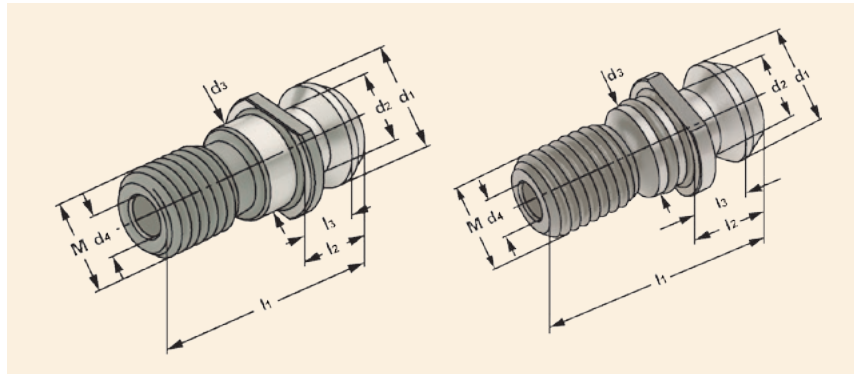

Order no.	M	l ₁	l ₂	l ₃	d ₁	d ₂	d ₃	d ₄
PS.7388.40.C.S	M16	44,5	16,40	11,15	18,95	12,95	17	7,0
PS.7388.50.C.S	M24	65,5	25,55	17,95	29,10	19,60	25	11,5

Form C.S (with drill through, incl. O-ring)

PS.7388.40.S	M16	44,5	16,40	11,15	18,95	12,95	17	-
PS.7388.50.S	M24	65,5	25,55	17,95	29,10	19,60	25	-

Form S (sealed, without drill through, incl. O-ring)

DIN 69871

ISO 60

MAS 403 BT

DIN 2080

HSK-A

VDI

MORSE



PS-BT

PULL STUDS MAS 403 BT WITH COOLANT HOLE - SEALED

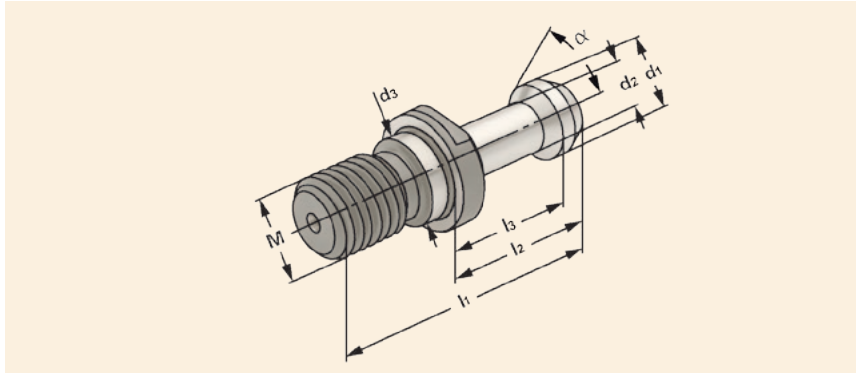

Order no.	M	l_1	l_2	l_3	d_1	d_2	d_3
PS.BT.30.45	M12 – 45°	43	23	18	11	7	12,5
PS.BT.30.60	M12 – 60°	43	23	18	11	7	12,5
PS.BT.40.45	M16 – 45°	60	35	28	15	10	17,0
PS.BT.40.60	M16 – 60°	60	35	28	15	10	17,0
PS.BT.40.90	M16 – 90°	60	35	28	15	10	17,0
PS.BT.50.45	M24 – 45°	85	45	35	23	17	25,0
PS.BT.50.60	M24 – 60°	85	45	35	23	17	25,0
PS.BT.50.90	M24 – 90°	85	45	35	23	17	25,0

Without drill through, without O-ring

DIN 69871

ISO 60

MAS 403 BT

DIN 2080

HSK-A

VDI

MORSE



PS-BT-C-S

PULL STUDS MAS 403 BT WITH COOLANT HOLE - SEALED

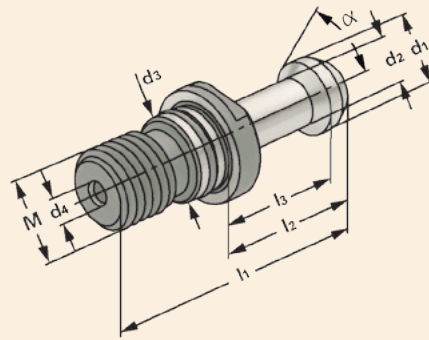

Order no.	M	l_1	l_2	l_3	d_1	d_2	d_3	d_4
PS.BT.30.45.C.S	M12 – 45°	43	23	18	11	7	12,5	2,5
PS.BT.30.60.C.S	M12 – 60°	43	23	18	11	7	12,5	2,5
PS.BT.40.45.C.S	M16 – 45°	60	35	28	15	10	17,0	4,0
PS.BT.40.60.C.S	M16 – 60°	60	35	28	15	10	17,0	4,0
PS.BT.40.90.C.S	M16 – 90°	60	35	28	15	10	17,0	4,0
PS.BT.50.45.C.S	M24 – 45°	85	45	35	23	17	25,0	6,0
PS.BT.50.60.C.S	M24 – 60°	85	45	35	23	17	25,0	6,0
PS.BT.50.90.C.S	M24 – 90°	85	45	35	23	17	25,0	6,0

Form C.S (with drill through, with O-ring)

PS-2080-C

PULL STUDS DIN 2080 WITH COOLANT HOLE

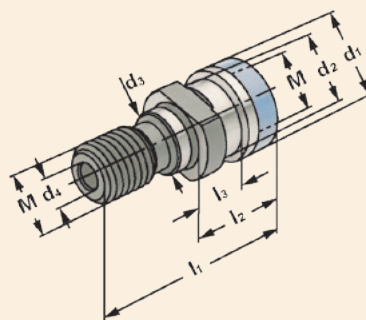

Order no.	M	l_1	l_2	l_3	d_1	d_2	d_3	d_4
PS.2080.40.C	M16	53,0	25,1	13,6	25,00	21,1	17	7,0
PS.2080.50.C	M24	65,1	25,1	13,3	39,60	32,0	25	7,0

With internal thread and drill through

Note:

With protection ring

DIN 69871

ISO 60

MAS 403 BT

DIN 2080

HSK-A

VDI

MORSE



OZ-C

OZ COLLETS FOR CYLINDRICAL SHAFT



Application:

For mounting straight-shank tools in collet chucks DIN 6391.
For highest axial and radial loading.

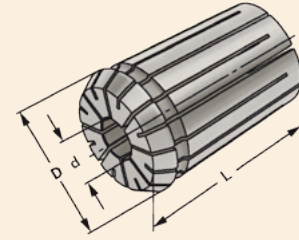

$\nabla \leq 0,015$

Order no.	Size	d	D	L
OZ16.C.02	OZ 16	2 – 1,5	25,5	40
OZ16.C.03	OZ 16	3 – 2,5	25,5	40
OZ16.C.04	OZ 16	4 – 3,5	25,5	40
OZ16.C.05	OZ 16	5 – 4,5	25,5	40
OZ16.C.06	OZ 16	6 – 5,5	25,5	40
OZ16.C.07	OZ 16	7 – 6,5	25,5	40
OZ16.C.08	OZ 16	8 – 7,5	25,5	40
OZ16.C.09	OZ 16	9 – 8,5	25,5	40
OZ16.C.10	OZ 16	10 – 9,5	25,5	40
OZ16.C.11	OZ 16	11 – 10,5	25,5	40
OZ16.C.12	OZ 16	12 – 11,5	25,5	40
OZ16.C.13	OZ 16	13 – 12,5	25,5	40
OZ16.C.14	OZ 16	14 – 13,5	25,5	40
OZ16.C.15	OZ 16	15 – 14,5	25,5	40
OZ16.C.16	OZ 16	16 – 15,5	25,5	40
OZ25.C.02	OZ 25	2 – 1,5	35,05	52
OZ25.C.03	OZ 25	3 – 2,5	35,05	52
OZ25.C.04	OZ 25	4 – 3,5	35,05	52
OZ25.C.05	OZ 25	5 – 4,5	35,05	52
OZ25.C.06	OZ 25	6 – 5,5	35,05	52
OZ25.C.07	OZ 25	7 – 6,5	35,05	52
OZ25.C.08	OZ 25	8 – 7,5	35,05	52
OZ25.C.09	OZ 25	9 – 8,5	35,05	52
OZ25.C.10	OZ 25	10 – 9,5	35,05	52
OZ25.C.11	OZ 25	11 – 10,5	35,05	52
OZ25.C.12	OZ 25	12 – 11,5	35,05	52
OZ25.C.13	OZ 25	13 – 12,5	35,05	52
OZ25.C.14	OZ 25	14 – 13,5	35,05	52
OZ25.C.15	OZ 25	15 – 14,5	35,05	52
OZ25.C.16	OZ 25	16 – 15,5	35,05	52
OZ25.C.17	OZ 25	17 – 16,5	35,05	52
OZ25.C.18	OZ 25	18 – 17,5	35,05	52
OZ25.C.19	OZ 25	19 – 18,5	35,05	52
OZ25.C.20	OZ 25	20 – 19,5	35,05	52
OZ25.C.21	OZ 25	21 – 20,5	35,05	52
OZ25.C.22	OZ 25	22 – 21,5	35,05	52

DIN 69871

ISO 60

MAS 403 BT

DIN 2080

HSK-A

VDI

MORSE



Order no.	Size	d	D	L
OZ25.C.23	OZ 25	23 – 22,5	35,05	52
OZ25.C.24	OZ 25	24 – 23,5	35,05	52
OZ25.C.25	OZ 25	25 – 24,5	35,05	52
OZ32.C.03	OZ 32	3 – 2,5	43,7	60
OZ32.C.04	OZ 32	4 – 3,5	43,7	60
OZ32.C.05	OZ 32	5 – 4,5	43,7	60
OZ32.C.06	OZ 32	6 – 5,5	43,7	60
OZ32.C.07	OZ 32	7 – 6,5	43,7	60
OZ32.C.08	OZ 32	8 – 7,5	43,7	60
OZ32.C.09	OZ 32	9 – 8,5	43,7	60
OZ32.C.10	OZ 32	10 – 9,5	43,7	60
OZ32.C.11	OZ 32	11 – 10,5	43,7	60
OZ32.C.12	OZ 32	12 – 11,5	43,7	60
OZ32.C.13	OZ 32	13 – 12,5	43,7	60
OZ32.C.14	OZ 32	14 – 13,5	43,7	60
OZ32.C.15	OZ 32	15 – 14,5	43,7	60
OZ32.C.16	OZ 32	16 – 15,5	43,7	60
OZ32.C.17	OZ 32	17 – 16,5	43,7	60
OZ32.C.18	OZ 32	18 – 17,5	43,7	60
OZ32.C.19	OZ 32	19 – 18,5	43,7	60
OZ32.C.20	OZ 32	20 – 19,5	43,7	60
OZ32.C.21	OZ 32	21 – 20,5	43,7	60
OZ32.C.22	OZ 32	22 – 21,5	43,7	60
OZ32.C.23	OZ 32	23 – 22,5	43,7	60
OZ32.C.24	OZ 32	24 – 23,5	43,7	60
OZ32.C.25	OZ 32	25 – 24,5	43,7	60
OZ32.C.26	OZ 32	26 – 25,5	43,7	60
OZ32.C.27	OZ 32	27 – 26,5	43,7	60
OZ32.C.28	OZ 32	28 – 27,5	43,7	60
OZ32.C.29	OZ 32	29 – 28,5	43,7	60
OZ32.C.30	OZ 32	30 – 29,5	43,7	60
OZ32.C.31	OZ 32	31 – 30,5	43,7	60
OZ32.C.32	OZ 32	32 – 31,5	43,7	60

DIN 69871

ISO 60

MAS 403 BT

DIN 2080

HSK-A

VDI

MORSE



OZ-C-P

OZ PRECISION COLLETS FOR CYLINDRICAL SHAFT



Application:

For mounting straight-shank tools in collet chucks DIN 6391. To use for high speed cutting and high precision milling.

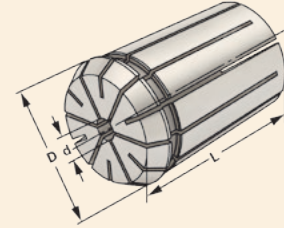

$\nabla \leq 0,005$

Order no.	Size	d	D	L
OZ16.C.02.P	OZ 16	2 – 1,5	25,5	40
OZ16.C.03.P	OZ 16	3 – 2,5	25,5	40
OZ16.C.04.P	OZ 16	4 – 3,5	25,5	40
OZ16.C.05.P	OZ 16	5 – 4,5	25,5	40
OZ16.C.06.P	OZ 16	6 – 5,5	25,5	40
OZ16.C.07.P	OZ 16	7 – 6,5	25,5	40
OZ16.C.08.P	OZ 16	8 – 7,5	25,5	40
OZ16.C.09.P	OZ 16	9 – 8,5	25,5	40
OZ16.C.10.P	OZ 16	10 – 9,5	25,5	40
OZ16.C.11.P	OZ 16	11 – 10,5	25,5	40
OZ16.C.12.P	OZ 16	12 – 11,5	25,5	40
OZ16.C.13.P	OZ 16	13 – 12,5	25,5	40
OZ16.C.14.P	OZ 16	14 – 13,5	25,5	40
OZ16.C.15.P	OZ 16	15 – 14,5	25,5	40
OZ16.C.16.P	OZ 16	16 – 15,5	25,5	40
OZ25.C.02.P	OZ 25	2 – 1,5	35,05	52
OZ25.C.03.P	OZ 25	3 – 2,5	35,05	52
OZ25.C.04.P	OZ 25	4 – 3,5	35,05	52
OZ25.C.05.P	OZ 25	5 – 4,5	35,05	52
OZ25.C.06.P	OZ 25	6 – 5,5	35,05	52
OZ25.C.07.P	OZ 25	7 – 6,5	35,05	52
OZ25.C.08.P	OZ 25	8 – 7,5	35,05	52
OZ25.C.09.P	OZ 25	9 – 8,5	35,05	52
OZ25.C.10.P	OZ 25	10 – 9,5	35,05	52
OZ25.C.11.P	OZ 25	11 – 10,5	35,05	52
OZ25.C.12.P	OZ 25	12 – 11,5	35,05	52
OZ25.C.13.P	OZ 25	13 – 12,5	35,05	52
OZ25.C.14.P	OZ 25	14 – 13,5	35,05	52
OZ25.C.15.P	OZ 25	15 – 14,5	35,05	52
OZ25.C.16.P	OZ 25	16 – 15,5	35,05	52
OZ25.C.17.P	OZ 25	17 – 16,5	35,05	52
OZ25.C.18.P	OZ 25	18 – 17,5	35,05	52
OZ25.C.19.P	OZ 25	19 – 18,5	35,05	52
OZ25.C.20.P	OZ 25	20 – 19,5	35,05	52
OZ25.C.21.P	OZ 25	21 – 20,5	35,05	52
OZ25.C.22.P	OZ 25	22 – 21,5	35,05	52

DIN 69871

ISO 60

MAS 403 BT

DIN 2080

HSK-A

VDI

MORSE



Order no.	Size	d	D	L
OZ25.C.23.P	OZ 25	23 – 22,5	35,05	52
OZ25.C.24.P	OZ 25	24 – 23,5	35,05	52
OZ25.C.25.P	OZ 25	25 – 24,5	35,05	52
OZ32.C.03.P	OZ 32	3 – 2,5	43,7	60
OZ32.C.04.P	OZ 32	4 – 3,5	43,7	60
OZ32.C.05.P	OZ 32	5 – 4,5	43,7	60
OZ32.C.06.P	OZ 32	6 – 5,5	43,7	60
OZ32.C.07.P	OZ 32	7 – 6,5	43,7	60
OZ32.C.08.P	OZ 32	8 – 7,5	43,7	60
OZ32.C.09.P	OZ 32	9 – 8,5	43,7	60
OZ32.C.10.P	OZ 32	10 – 9,5	43,7	60
OZ32.C.11.P	OZ 32	11 – 10,5	43,7	60
OZ32.C.12.P	OZ 32	12 – 11,5	43,7	60
OZ32.C.13.P	OZ 32	13 – 12,5	43,7	60
OZ32.C.14.P	OZ 32	14 – 13,5	43,7	60
OZ32.C.15.P	OZ 32	15 – 14,5	43,7	60
OZ32.C.16.P	OZ 32	16 – 15,5	43,7	60
OZ32.C.17.P	OZ 32	17 – 16,5	43,7	60
OZ32.C.18.P	OZ 32	18 – 17,5	43,7	60
OZ32.C.19.P	OZ 32	19 – 18,5	43,7	60
OZ32.C.20.P	OZ 32	20 – 19,5	43,7	60
OZ32.C.21.P	OZ 32	21 – 20,5	43,7	60
OZ32.C.22.P	OZ 32	22 – 21,5	43,7	60
OZ32.C.23.P	OZ 32	23 – 22,5	43,7	60
OZ32.C.24.P	OZ 32	24 – 23,5	43,7	60
OZ32.C.25.P	OZ 32	25 – 24,5	43,7	60
OZ32.C.26.P	OZ 32	26 – 25,5	43,7	60
OZ32.C.27.P	OZ 32	27 – 26,5	43,7	60
OZ32.C.28.P	OZ 32	28 – 27,5	43,7	60
OZ32.C.29.P	OZ 32	29 – 28,5	43,7	60
OZ32.C.30.P	OZ 32	30 – 29,5	43,7	60
OZ32.C.31.P	OZ 32	31 – 30,5	43,7	60
OZ32.C.32.P	OZ 32	32 – 31,5	43,7	60

DIN 69871

ISO 60

MAS 403 BT

DIN 2080

HSK-A

VDI

MORSE



OZ-C-SET-WP

OZ COLLETS FOR CYLINDRICAL SHANK - SETS IN WOODEN PLATE



Application:
For mounting straight-shank tools in
collet chucks DIN 6388/DIN 6499.

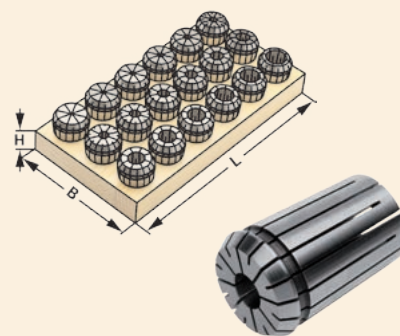

$\nabla \leq 0,015$

Order no.	Size	L	B	H
OZ16.C.SET15.WP	415E (OZ 16; 15 pcs) 2-3-4-5-6-7-8-9-10-11-12-13-14-15-16	150	195	25
OZ25.C.SET15.WP	462E (OZ 25; 15 pcs) 4-5-6-7-8-9-10-11-12-14-16-18-20-22-25	290	240	30
OZ32.C.SET16.WP	467E (OZ 32; 16 pcs) 5-6-7-8-10-12-14-16-18-20-22-24-25-28-30-32	290	240	30

OZ-C-SET-WB

OZ COLLETS FOR CYLINDRICAL SHANK - SETS IN WOODEN BOX



Application:
For mounting straight-shank tools in
collet chucks DIN 6388/DIN 6499.

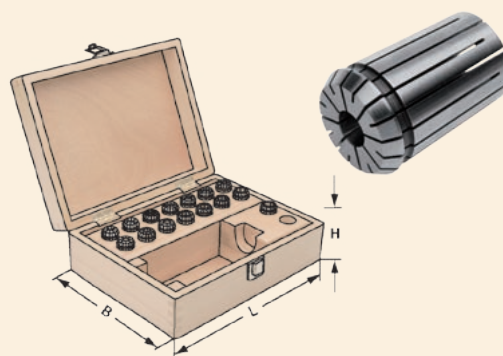

$\nabla \leq 0,015$

Order no.	Size	L	B	H
OZ16.C.SET15.WB	415E (OZ 16; 15 pcs) 2-3-4-5-6-7-8-9-10-11-12-13-14-15-16	360	235	70
OZ25.C.SET15.WB	462E (OZ 25; 15 pcs) 4-5-6-7-8-9-10-11-12-14-16-18-20-22-25	360	235	70
OZ32.C.SET16.WB	467E (OZ 32; 16 pcs) 5-6-7-8-10-12-14-16-18-20-22-24-25-28-30-32	360	235	70

Note: Collet chucks and wrenches to be ordered separately.

DIN 69871

ISO 60

MAS 403 BT

DIN 2080

HSK-A

VDI

MORSE



OZ-C-SET-P-WP

OZ PRECISION COLLETS FOR CYLINDRICAL SHANK - SETS IN WOODEN PLATE



Application:

For mounting straight-shank tools in collet chucks
DIN 6388/DIN 6499.

To use for high speed cutting and high precision milling.

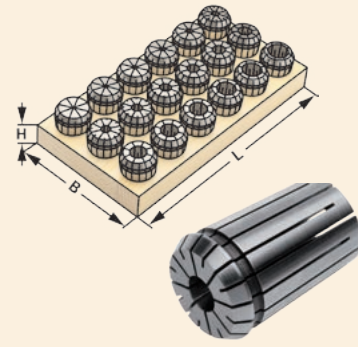

$\nabla \leq 0,005$

Order no.	Size	L	B	H
OZ16.C.SET15.P.WP	415E (OZ 16; 15 pcs) 2-3-4-5-6-7-8-9-10-11-12-13-14-15-16	150	195	25
OZ25.C.SET15.P.WP	462E (OZ 25; 15 pcs) 4-5-6-7-8-9-10-11-12-14-16-18-20-22-25	290	240	30
OZ32.C.SET16.P.WP	467E (OZ 32; 16 pcs) 5-6-7-8-10-12-14-16-18-20-22-24-25-28-30-32	290	240	30

OZ-C-SET-P-WB

OZ PRECISION COLLETS FOR CYLINDRICAL SHANK - SETS IN WOODEN BOX



Application:

For mounting straight-shank tools in
collet chucks DIN 6388/DIN 6499.

To use for high speed cutting and high
precision milling.

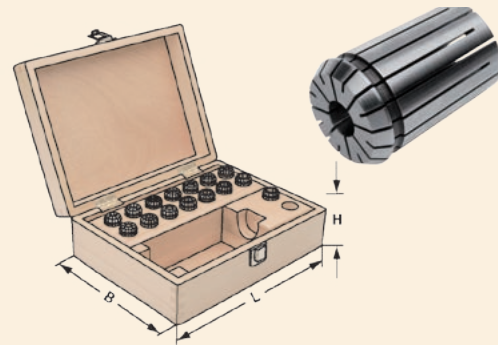

$\nabla \leq 0,005$

Order no.	Size	L	B	H
OZ16.C.SET15.P.WB	415E (OZ 16; 15 pcs) 2-3-4-5-6-7-8-9-10-11-12-13-14-15-16	360	235	70
OZ25.C.SET15.P.WB	462E (OZ 25; 15 pcs) 4-5-6-7-8-9-10-11-12-14-16-18-20-22-25	360	235	70
OZ32.C.SET16.P.WB	467E (OZ 32; 16 pcs) 5-6-7-8-10-12-14-16-18-20-22-24-25-28-30-32	360	235	70

Note: Collet chucks and wrenches to be ordered separately.

DIN 69871

ISO 60

MAS 403 BT

DIN 2080

HSK-A

VDI

MORSE



ER-C

ER COLLETS FOR CYLINDRICAL SHANK



Application:

For mounting straight-shank tools in collet chucks DIN 6499.

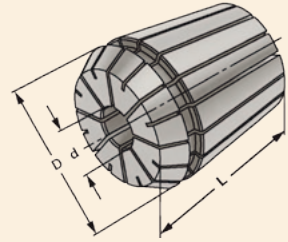

$\nabla \leq 0,015$

Order no.	Size	d	D	L
ER11.C.010	ER 11	1,0 – 0,5	8,5	18
ER11.C.015	ER 11	1,5 – 1,0	8,5	18
ER11.C.020	ER 11	2,0 – 1,5	8,5	18
ER11.C.025	ER 11	2,5 – 2,0	8,5	18
ER11.C.030	ER 11	3,0 – 2,5	8,5	18
ER11.C.035	ER 11	3,5 – 3,0	8,5	18
ER11.C.040	ER 11	4,0 – 3,5	8,5	18
ER11.C.045	ER 11	4,5 – 4,0	8,5	18
ER11.C.050	ER 11	5,0 – 4,5	8,5	18
ER11.C.055	ER 11	5,5 – 5,0	8,5	18
ER11.C.060	ER 11	6,0 – 5,5	8,5	18
ER11.C.065	ER 11	6,5 – 6,0	8,5	18
ER11.C.070	ER 11	7,0 – 6,5	8,5	18
ER16.C.01	ER 16	1 – 0,5	17	27
ER16.C.02	ER 16	2 – 1	17	27
ER16.C.03	ER 16	3 – 2	17	27
ER16.C.04	ER 16	4 – 3	17	27
ER16.C.05	ER 16	5 – 4	17	27
ER16.C.06	ER 16	6 – 5	17	27
ER16.C.07	ER 16	7 – 6	17	27
ER16.C.08	ER 16	8 – 7	17	27
ER16.C.09	ER 16	9 – 8	17	27
ER16.C.10	ER 16	10 – 9	17	27
ER25.C.02	ER 25	2 – 1,5	26	34
ER25.C.03	ER 25	3 – 2	26	34
ER25.C.04	ER 25	4 – 3	26	34
ER25.C.05	ER 25	5 – 4	26	34
ER25.C.06	ER 25	6 – 5	26	34
ER25.C.07	ER 25	7 – 6	26	34
ER25.C.08	ER 25	8 – 7	26	34
ER25.C.09	ER 25	9 – 8	26	34
ER25.C.10	ER 25	10 – 9	26	34
ER25.C.11	ER 25	11 – 10	26	34
ER25.C.12	ER 25	12 – 11	26	34
ER25.C.13	ER 25	13 – 12	26	34

DIN 69871

ISO 60

MAS 403 BT

DIN 2080

HSK-A

VDI

MORSE



Order no.	Size	d	D	L
ER25.C.14	ER 25	14 – 13	26	34
ER25.C.15	ER 25	15 – 14	26	34
ER25.C.16	ER 25	16 – 15	26	34
ER32.C.02	ER 32	2 – 1,5	33	40
ER32.C.03	ER 32	3 – 2	33	40
ER32.C.04	ER 32	4 – 3	33	40
ER32.C.05	ER 32	5 – 4	33	40
ER32.C.06	ER 32	6 – 5	33	40
ER32.C.07	ER 32	7 – 6	33	40
ER32.C.08	ER 32	8 – 7	33	40
ER32.C.09	ER 32	9 – 8	33	40
ER32.C.10	ER 32	10 – 9	33	40
ER32.C.11	ER 32	11 – 10	33	40
ER32.C.12	ER 32	12 – 11	33	40
ER32.C.13	ER 32	13 – 12	33	40
ER32.C.14	ER 32	14 – 13	33	40
ER32.C.15	ER 32	15 – 14	33	40
ER32.C.16	ER 32	16 – 15	33	40
ER32.C.17	ER 32	17 – 16	33	40
ER32.C.18	ER 32	18 – 17	33	40
ER32.C.19	ER 32	19 – 18	33	40
ER32.C.20	ER 32	20 – 19	33	40
ER40.C.03	ER 40	3 – 2,5	41	46
ER40.C.04	ER 40	4 – 3	41	46
ER40.C.05	ER 40	5 – 4	41	46
ER40.C.06	ER 40	6 – 5	41	46
ER40.C.07	ER 40	7 – 6	41	46
ER40.C.08	ER 40	8 – 7	41	46
ER40.C.09	ER 40	9 – 8	41	46
ER40.C.10	ER 40	10 – 9	41	46
ER40.C.11	ER 40	11 – 10	41	46
ER40.C.12	ER 40	12 – 11	41	46
ER40.C.13	ER 40	13 – 12	41	46
ER40.C.14	ER 40	14 – 13	41	46
ER40.C.15	ER 40	15 – 14	41	46
ER40.C.16	ER 40	16 – 15	41	46
ER40.C.17	ER 40	17 – 16	41	46
ER40.C.18	ER 40	18 – 17	41	46
ER40.C.19	ER 40	19 – 18	41	46
ER40.C.20	ER 40	20 – 19	41	46
ER40.C.21	ER 40	21 – 20	41	46
ER40.C.22	ER 40	22 – 21	41	46
ER40.C.23	ER 40	23 – 22	41	46
ER40.C.24	ER 40	24 – 23	41	46
ER40.C.25	ER 40	25 – 24	41	46
ER40.C.26	ER 40	26 – 25	41	46

Note: Clamping range up to –1 mm, only size ER11 up to –0,5 mm

DIN 69871

ISO 60

MAS 403 BT

DIN 2080

HSK-A

VDI

MORSE



ER-C-P

ER PRECISION COLLETS FOR CYLINDRICAL SHANK



Application:

For mounting straight-shank tools in collet chucks DIN 6499. To use for high speed cutting and high precision milling.

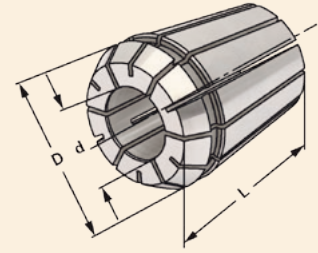

$\nabla \leq 0,005$

Order no.	Size	d	D	L
ER11.C.010.P	ER 11	1,0 – 0,5	8,5	18
ER11.C.015.P	ER 11	1,5 – 1,0	8,5	18
ER11.C.020.P	ER 11	2,0 – 1,5	8,5	18
ER11.C.025.P	ER 11	2,5 – 2,0	8,5	18
ER11.C.030.P	ER 11	3,0 – 2,5	8,5	18
ER11.C.035.P	ER 11	3,5 – 3,0	8,5	18
ER11.C.040.P	ER 11	4,0 – 3,5	8,5	18
ER11.C.045.P	ER 11	4,5 – 4,0	8,5	18
ER11.C.050.P	ER 11	5,0 – 4,5	8,5	18
ER11.C.055.P	ER 11	5,5 – 5,0	8,5	18
ER11.C.060.P	ER 11	6,0 – 5,5	8,5	18
ER11.C.065.P	ER 11	6,5 – 6,0	8,5	18
ER11.C.070.P	ER 11	7,0 – 6,5	8,5	18
ER16.C.01.P	ER 16	1 – 0,5	17	27
ER16.C.02.P	ER 16	2 – 1	17	27
ER16.C.03.P	ER 16	3 – 2	17	27
ER16.C.04.P	ER 16	4 – 3	17	27
ER16.C.05.P	ER 16	5 – 4	17	27
ER16.C.06.P	ER 16	6 – 5	17	27
ER16.C.07.P	ER 16	7 – 6	17	27
ER16.C.08.P	ER 16	8 – 7	17	27
ER16.C.09.P	ER 16	9 – 8	17	27
ER16.C.10.P	ER 16	10 – 9	17	27
ER25.C.02.P	ER 25	2 – 1,5	26	34
ER25.C.03.P	ER 25	3 – 2	26	34
ER25.C.04.P	ER 25	4 – 3	26	34
ER25.C.05.P	ER 25	5 – 4	26	34
ER25.C.06.P	ER 25	6 – 5	26	34
ER25.C.07.P	ER 25	7 – 6	26	34
ER25.C.08.P	ER 25	8 – 7	26	34
ER25.C.09.P	ER 25	9 – 8	26	34
ER25.C.10.P	ER 25	10 – 9	26	34
ER25.C.11.P	ER 25	11 – 10	26	34
ER25.C.12.P	ER 25	12 – 11	26	34
ER25.C.13.P	ER 25	13 – 12	26	34

DIN 69871

ISO 60

MAS 403 BT

DIN 2080

HSK-A

VDI

MORSE



Order no.	Size	d	D	L
ER25.C.14.P	ER 25	14 – 13	26	34
ER25.C.15.P	ER 25	15 – 14	26	34
ER25.C.16.P	ER 25	16 – 15	26	34
ER32.C.02.P	ER 32	2 – 1,5	33	40
ER32.C.03.P	ER 32	3 – 2	33	40
ER32.C.04.P	ER 32	4 – 3	33	40
ER32.C.05.P	ER 32	5 – 4	33	40
ER32.C.06.P	ER 32	6 – 5	33	40
ER32.C.07.P	ER 32	7 – 6	33	40
ER32.C.08.P	ER 32	8 – 7	33	40
ER32.C.09.P	ER 32	9 – 8	33	40
ER32.C.10.P	ER 32	10 – 9	33	40
ER32.C.11.P	ER 32	11 – 10	33	40
ER32.C.12.P	ER 32	12 – 11	33	40
ER32.C.13.P	ER 32	13 – 12	33	40
ER32.C.14.P	ER 32	14 – 13	33	40
ER32.C.15.P	ER 32	15 – 14	33	40
ER32.C.16.P	ER 32	16 – 15	33	40
ER32.C.17.P	ER 32	17 – 16	33	40
ER32.C.18.P	ER 32	18 – 17	33	40
ER32.C.19.P	ER 32	19 – 18	33	40
ER32.C.20.P	ER 32	20 – 19	33	40
ER40.C.03.P	ER 40	3 – 2,5	41	46
ER40.C.04.P	ER 40	4 – 3	41	46
ER40.C.05.P	ER 40	5 – 4	41	46
ER40.C.06.P	ER 40	6 – 5	41	46
ER40.C.07.P	ER 40	7 – 6	41	46
ER40.C.08.P	ER 40	8 – 7	41	46
ER40.C.09.P	ER 40	9 – 8	41	46
ER40.C.10.P	ER 40	10 – 9	41	46
ER40.C.11.P	ER 40	11 – 10	41	46
ER40.C.12.P	ER 40	12 – 11	41	46
ER40.C.13.P	ER 40	13 – 12	41	46
ER40.C.14.P	ER 40	14 – 13	41	46
ER40.C.15.P	ER 40	15 – 14	41	46
ER40.C.16.P	ER 40	16 – 15	41	46
ER40.C.17.P	ER 40	17 – 16	41	46
ER40.C.18.P	ER 40	18 – 17	41	46
ER40.C.19.P	ER 40	19 – 18	41	46
ER40.C.20.P	ER 40	20 – 19	41	46
ER40.C.21.P	ER 40	21 – 20	41	46
ER40.C.22.P	ER 40	22 – 21	41	46
ER40.C.23.P	ER 40	23 – 22	41	46
ER40.C.24.P	ER 40	24 – 23	41	46
ER40.C.25.P	ER 40	25 – 24	41	46
ER40.C.26.P	ER 40	26 – 25	41	46

Note: Clamping range up to –1 mm, only size ER11 up to –0,5 mm

DIN 69871

ISO 60

MAS 403 BT

DIN 2080

HSK-A

VDI

MORSE



ER-C-S

ER SEALED COLLETS FOR CYLINDRICAL SHANK



Application:

For mounting straight-shank tools in collet chucks DIN 6499.

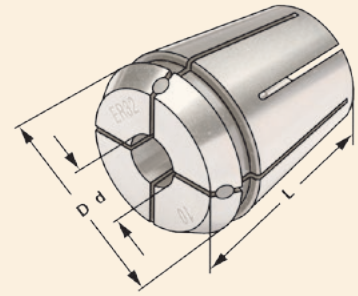
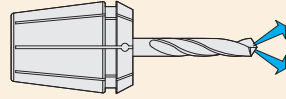

$\nabla \leq 0,015$

Order no.	Size	d	D	L
ER16.C.03.S	ER 16	3	17	27
ER16.C.04.S	ER 16	4	17	27
ER16.C.05.S	ER 16	5	17	27
ER16.C.06.S	ER 16	6	17	27
ER16.C.07.S	ER 16	7	17	27
ER16.C.08.S	ER 16	8	17	27
ER16.C.09.S	ER 16	9	17	27
ER16.C.10.S	ER 16	10	17	27
ER25.C.03.S	ER 25	3	26	34
ER25.C.04.S	ER 25	4	26	34
ER25.C.05.S	ER 25	5	26	34
ER25.C.06.S	ER 25	6	26	34
ER25.C.07.S	ER 25	7	26	34
ER25.C.08.S	ER 25	8	26	34
ER25.C.09.S	ER 25	9	26	34
ER25.C.10.S	ER 25	10	26	34
ER25.C.11.S	ER 25	11	26	34
ER25.C.12.S	ER 25	12	26	34
ER25.C.13.S	ER 25	13	26	34
ER25.C.14.S	ER 25	14	26	34
ER25.C.15.S	ER 25	15	26	34
ER25.C.16.S	ER 25	16	26	34
ER32.C.03.S	ER 32	3	33	40
ER32.C.04.S	ER 32	4	33	40
ER32.C.05.S	ER 32	5	33	40
ER32.C.06.S	ER 32	6	33	40
ER32.C.07.S	ER 32	7	33	40
ER32.C.08.S	ER 32	8	33	40
ER32.C.09.S	ER 32	9	33	40
ER32.C.10.S	ER 32	10	33	40
ER32.C.11.S	ER 32	11	33	40
ER32.C.12.S	ER 32	12	33	40
ER32.C.13.S	ER 32	13	33	40
ER32.C.14.S	ER 32	14	33	40
ER32.C.15.S	ER 32	15	33	40

DIN 69871

ISO 60

MAS 403 BT

DIN 2080

HSK-A

VDI

MORSE



Order no.	Size	d	D	L
ER32.C.16.S	ER 32	16	33	40
ER32.C.17.S	ER 32	17	33	40
ER32.C.18.S	ER 32	18	33	40
ER32.C.19.S	ER 32	19	33	40
ER32.C.20.S	ER 32	20	33	40
ER40.C.03.S	ER 40	3	41	46
ER40.C.04.S	ER 40	4	41	46
ER40.C.05.S	ER 40	5	41	46
ER40.C.06.S	ER 40	6	41	46
ER40.C.07.S	ER 40	7	41	46
ER40.C.08.S	ER 40	8	41	46
ER40.C.09.S	ER 40	9	41	46
ER40.C.10.S	ER 40	10	41	46
ER40.C.11.S	ER 40	11	41	46
ER40.C.12.S	ER 40	12	41	46
ER40.C.13.S	ER 40	13	41	46
ER40.C.14.S	ER 40	14	41	46
ER40.C.15.S	ER 40	15	41	46
ER40.C.16.S	ER 40	16	41	46
ER40.C.17.S	ER 40	17	41	46
ER40.C.18.S	ER 40	18	41	46
ER40.C.19.S	ER 40	19	41	46
ER40.C.20.S	ER 40	20	41	46
ER40.C.21.S	ER 40	21	41	46
ER40.C.22.S	ER 40	22	41	46
ER40.C.23.S	ER 40	23	41	46
ER40.C.24.S	ER 40	24	41	46
ER40.C.25.S	ER 40	25	41	46
ER40.C.26.S	ER 40	26	41	46

Note: Only nominal size d can be clamped with sealing plug for internal cooling (applicable up to 21 bar)

DIN 69871

ISO 60

MAS 403 BT

DIN 2080

HSK-A

VDI

MORSE



ER-C-SC4

ER SEALED COLLETS WITH 4 COOLANT CHANNELS FOR CYLINDRICAL SHANK



Application:

For mounting straight-shank tools in collet chucks DIN 6499.

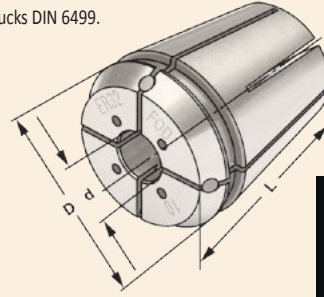

$\nabla \leq 0,015$

Order no.	Size	d	D	L
ER16.C.03.SC4	ER 16	3	17	27
ER16.C.04.SC4	ER 16	4	17	27
ER16.C.05.SC4	ER 16	5	17	27
ER16.C.06.SC4	ER 16	6	17	27
ER16.C.07.SC4	ER 16	7	17	27
ER25.C.03.SC4	ER 25	3	26	34
ER25.C.04.SC4	ER 25	4	26	34
ER25.C.05.SC4	ER 25	5	26	34
ER25.C.06.SC4	ER 25	6	26	34
ER25.C.07.SC4	ER 25	7	26	34
ER25.C.08.SC4	ER 25	8	26	34
ER25.C.09.SC4	ER 25	9	26	34
ER25.C.10.SC4	ER 25	10	26	34
ER25.C.11.SC4	ER 25	11	26	34
ER25.C.12.SC4	ER 25	12	26	34
ER25.C.13.SC4	ER 25	13	26	34
ER25.C.14.SC4	ER 25	14	26	34
ER32.C.03.SC4	ER 32	3	33	40
ER32.C.04.SC4	ER 32	4	33	40
ER32.C.05.SC4	ER 32	5	33	40
ER32.C.06.SC4	ER 32	6	33	40
ER32.C.07.SC4	ER 32	7	33	40
ER32.C.08.SC4	ER 32	8	33	40
ER32.C.09.SC4	ER 32	9	33	40
ER32.C.10.SC4	ER 32	10	33	40
ER32.C.11.SC4	ER 32	11	33	40
ER32.C.12.SC4	ER 32	12	33	40
ER32.C.13.SC4	ER 32	13	33	40
ER32.C.14.SC4	ER 32	14	33	40
ER32.C.15.SC4	ER 32	15	33	40
ER32.C.16.SC4	ER 32	16	33	40
ER32.C.17.SC4	ER 32	17	33	40
ER32.C.18.SC4	ER 32	18	33	40
ER32.C.19.SC4	ER 32	19	33	40
ER32.C.20.SC4	ER 32	20	33	40

DIN 69871

ISO 60

MAS 403 BT

DIN 2080

HSK-A

VDI

MORSE



Order no.	Size	d	D	L
ER40.C.04.SC4	ER 40	4	41	46
ER40.C.05.SC4	ER 40	5	41	46
ER40.C.06.SC4	ER 40	6	41	46
ER40.C.07.SC4	ER 40	7	41	46
ER40.C.08.SC4	ER 40	8	41	46
ER40.C.09.SC4	ER 40	9	41	46
ER40.C.10.SC4	ER 40	10	41	46
ER40.C.11.SC4	ER 40	11	41	46
ER40.C.12.SC4	ER 40	12	41	46
ER40.C.13.SC4	ER 40	13	41	46
ER40.C.14.SC4	ER 40	14	41	46
ER40.C.15.SC4	ER 40	15	41	46
ER40.C.16.SC4	ER 40	16	41	46
ER40.C.17.SC4	ER 40	17	41	46
ER40.C.18.SC4	ER 40	18	41	46
ER40.C.19.SC4	ER 40	19	41	46
ER40.C.20.SC4	ER 40	20	41	46
ER40.C.21.SC4	ER 40	21	41	46
ER40.C.22.SC4	ER 40	22	41	46
ER40.C.23.SC4	ER 40	23	41	46
ER40.C.24.SC4	ER 40	24	41	46
ER40.C.25.SC4	ER 40	25	41	46
ER40.C.26.SC4	ER 40	26	41	46

Note: Only nominal size d can be clamped, with cooling channels



DIN 69871

ISO 60

MAS 403 BT

DIN 2080

HSK-A

VDI

MORSE



ER-T

ER COLLETS WITH TAP SQUARE DRIVE



Application:
For machines with rigid tapping.
For safe clamping of taps.

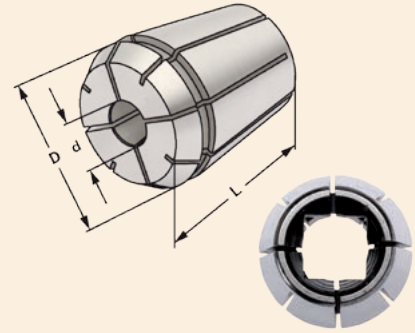

Order no.	Size	d	□	D	L
ER16.T.035.027	ER 16	3,5	2,7	17	27,5
ER16.T.040.030	ER 16	4	3	17	27,5
ER16.T.045.034	ER 16	4,5	3,4	17	27,5
ER16.T.060.049	ER 16	6	4,9	17	27,5
ER16.T.070.055	ER 16	7	5,5	17	27,5
ER16.T.080.062	ER 16	8	6,2	17	27,5
ER25.T.035.027	ER 25	3,5	2,7	26	34
ER25.T.040.030	ER 25	4	3	26	34
ER25.T.045.034	ER 25	4,5	3,4	26	34
ER25.T.060.049	ER 25	6	4,9	26	34
ER25.T.070.055	ER 25	7	5,5	26	34
ER25.T.080.062	ER 25	8	6,2	26	34
ER25.T.090.070	ER 25	9	7	26	34
ER25.T.100.080	ER 25	10	8	26	34
ER25.T.110.090	ER 25	11	9	26	34
ER25.T.120.090	ER 25	12	9	26	34
ER32.T.045.034	ER 32	4,5	3,4	33	40
ER32.T.060.049	ER 32	6	4,9	33	40
ER32.T.070.055	ER 32	7	5,5	33	40
ER32.T.080.062	ER 32	8	6,2	33	40
ER32.T.090.070	ER 32	9	7	33	40
ER32.T.100.080	ER 32	10	8	33	40
ER32.T.110.090	ER 32	11	9	33	40
ER32.T.120.090	ER 32	12	9	33	40
ER32.T.140.110	ER 32	14	11	33	40
ER32.T.160.120	ER 32	16	12	33	40
ER40.T.060.049	ER 40	6	4,9	41	46
ER40.T.070.055	ER 40	7	5,5	41	46
ER40.T.080.062	ER 40	8	6,2	41	46
ER40.T.090.070	ER 40	9	7	41	46
ER40.T.100.080	ER 40	10	8	41	46
ER40.T.110.090	ER 40	11	9	41	46
ER40.T.120.090	ER 40	12	9	41	46
ER40.T.140.110	ER 40	14	11	41	46

DIN 69871

ISO 60

MAS 403 BT

DIN 2080

HSK-A

VDI

MORSE



Order no.	Size	d		D	L
ER40.T.160.120	ER 40	16	12	41	46
ER40.T.180.145	ER 40	18	14,5	41	46
ER40.T.200.160	ER 40	20	16	41	46

DIN 69871

ISO 60

MAS 403 BT

DIN 2080

HSK-A

VDI

MORSE



ER-T-SC4

ER SEALED COLLETS WITH 4 COOLANT CHANNELS AND TAPS SQUARE DRIVE



Application:

For mounting straight-shank tools in collet chucks DIN 6499.

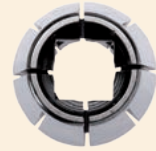
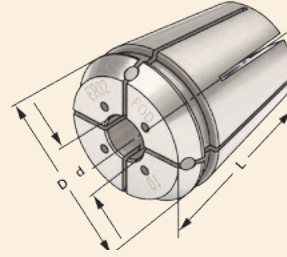

Order no.	Size	d	□	D	L
ER16.T.035.027.SC4	ER 16	3,5	2,7	17	27,5
ER16.T.040.030.SC4	ER 16	4	3	17	27,5
ER16.T.045.034.SC4	ER 16	4,5	3,4	17	27,5
ER16.T.060.049.SC4	ER 16	6	4,9	17	27,5
ER16.T.070.055.SC4	ER 16	7	5,5	17	27,5
ER16.T.080.062.SC4	ER 16	8	6,2	17	27,5
ER25.T.035.027.SC4	ER 25	3,5	2,7	26	34
ER25.T.040.030.SC4	ER 25	4	3	26	34
ER25.T.045.034.SC4	ER 25	4,5	3,4	26	34
ER25.T.060.049.SC4	ER 25	6	4,9	26	34
ER25.T.070.055.SC4	ER 25	7	5,5	26	34
ER25.T.080.062.SC4	ER 25	8	6,2	26	34
ER25.T.090.070.SC4	ER 25	9	7	26	34
ER25.T.100.080.SC4	ER 25	10	8	26	34
ER25.T.110.090.SC4	ER 25	11	9	26	34
ER25.T.120.090.SC4	ER 25	12	9	26	34
ER32.T.045.034.SC4	ER 32	4,5	3,4	33	40
ER32.T.060.049.SC4	ER 32	6	4,9	33	40
ER32.T.070.055.SC4	ER 32	7	5,5	33	40
ER32.T.080.062.SC4	ER 32	8	6,2	33	40
ER32.T.090.070.SC4	ER 32	9	7	33	40
ER32.T.100.080.SC4	ER 32	10	8	33	40
ER32.T.110.090.SC4	ER 32	11	9	33	40
ER32.T.120.090.SC4	ER 32	12	9	33	40
ER32.T.140.110.SC4	ER 32	14	11	33	40
ER32.T.160.120.SC4	ER 32	16	12	33	40
ER40.T.060.049.SC4	ER 40	6	4,9	41	46
ER40.T.070.055.SC4	ER 40	7	5,5	41	46
ER40.T.080.062.SC4	ER 40	8	6,2	41	46
ER40.T.090.070.SC4	ER 40	9	7	41	46
ER40.T.100.080.SC4	ER 40	10	8	41	46
ER40.T.110.090.SC4	ER 40	11	9	41	46
ER40.T.120.090.SC4	ER 40	12	9	41	46
ER40.T.140.110.SC4	ER 40	14	11	41	46

DIN 69871

ISO 60

MAS 403 BT

DIN 2080

HSK-A

VDI

MORSE



Order no.	Size	d	□	D	L
ER40.T.160.120.SC4	ER 40	16	12	41	46
ER40.T.180.145.SC4	ER 40	18	14,5	41	46
ER40.T.200.160.SC4	ER 40	20	16	41	46

DIN 69871

ISO 60

MAS 403 BT

DIN 2080

HSK-A

VDI

MORSE



ER-C-SET-WP

ER COLLETS FOR CYLINDRICAL SHANK - SETS IN WOODEN PLATE



Application:
For mounting straight-shank tools in
collet chucks DIN 6388/DIN 6499.

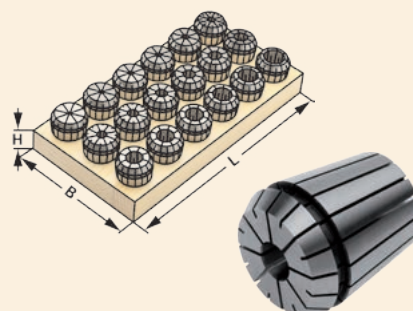

$\nabla \leq 0,015$

Order no.	Size	L	B	H
ER11.C.SET13.WP	4008E (ER 11; 13 pcs) 1-1,5-2-2,5-3-3,5-4-4,5-5-5,5-6-6,5-7	125	45	20
ER16.C.SET10.WP	426E (ER 16; 10 pcs) 1-2-3-4-5-6-7-8-9-10	130	50	25
ER25.C.SET15.WP	430E (ER 25; 15 pcs) 2-3-4-5-6-7-8-9-10-11-12-13-14-15-16	150	195	25
ER32.C.SET18.WP	470E (ER 32; 18 pcs) 3-4-5-6-7-8-9-10-11-12-13-14-15-16-17-18-19-20	190	150	30
ER40.C.SET23.WP	472E (ER 40; 23 pcs) 4-5-6-7-8-9-10-11-12-13-14-15-16-17-18-19-20-21-22-23-24-25-26	290	195	25

ER-C-SET-WB

ER COLLETS FOR CYLINDRICAL SHANK - SETS IN WOODEN BOX



Application:
For mounting straight-shank tools in
collet chucks DIN 6388/DIN 6499.

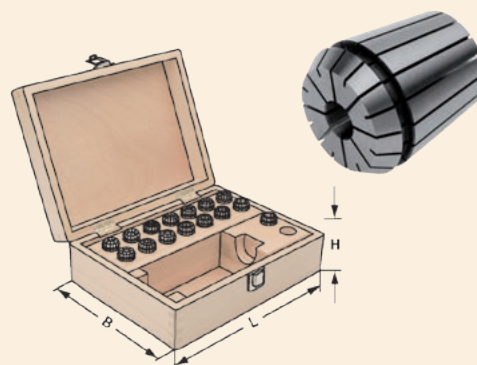

$\nabla \leq 0,015$

Order no.	Size	L	B	H
ER11.C.SET13.WB	4008E (ER 11; 13 pcs) 1-1,5-2-2,5-3-3,5-4-4,5-5-5,5-6-6,5-7	360	235	70
ER16.C.SET10.WB	426E (ER 16; 10 pcs) 1-2-3-4-5-6-7-8-9-10	360	235	70
ER25.C.SET15.WB	430E (ER 25; 15 pcs) 2-3-4-5-6-7-8-9-10-11-12-13-14-15-16	360	235	70
ER32.C.SET15.WB	470E (ER 32; 15 pcs) 3-4-5-6-7-8-9-10-11-12-14-15-16-18-20	360	235	70
ER40.C.SET16.WB	472E (ER 40; 16 pcs) 4-5-6-7-8-9-10-11-12-14-16-18-20-22-24-26	360	235	70

Note: Collet chucks and wrenches to be ordered separately.



ER-C-SET-P-WP

ER PRECISION COLLETS FOR CYLINDRICAL SHANK - SETS IN WOODEN PLATE



Application:

For mounting straight-shank tools in collet chucks DIN 6388/DIN 6499. To use for high speed cutting and high precision milling.

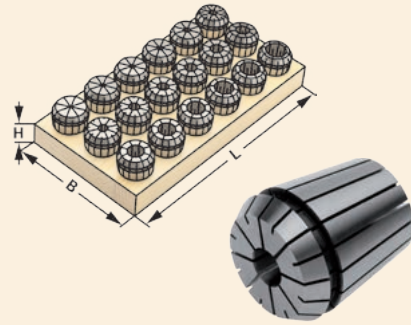

$\nearrow \leq 0,005$

Order no.	Size	L	B	H
ER11.C.SET13.PWP	4008E (ER 11; 13 pcs) 1-1,5-2-2,5-3-3,5-4-4,5-5-5,5-6-6,5-7	95	85	20
ER16.C.SET10.PWP	426E (ER 16; 10 pcs) 1-2-3-4-5-6-7-8-9-10	130	50	25
ER25.C.SET15.PWP	430E (ER 25; 15 pcs) 2-3-4-5-6-7-8-9-10-11-12-13-14-15-16	150	195	25
ER32.C.SET18.PWP	470E (ER 32; 18 pcs) 3-4-5-6-7-8-9-10-11-12-13-14-15-16-17-18-19-20	190	150	30
ER40.C.SET23.PWP	472E (ER 40; 23 pcs) 4-5-6-7-8-9-10-11-12-13-14-15-16-17-18-19-20-21-22-23-24-25-26	290	195	25

ER-C-SET-P-WB

ER PRECISION COLLETS FOR CYLINDRICAL SHANK - SETS IN WOODEN BOX



Application:

For mounting straight-shank tools in collet chucks DIN 6388/DIN 6499. To use for high speed cutting and high precision milling.

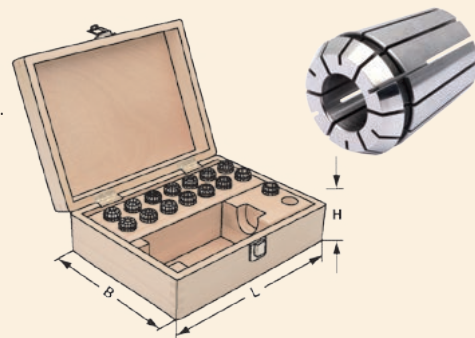

$\nearrow \leq 0,005$

Order no.	Size	L	B	H
ER11.C.SET13.PWB	4008E (ER 11; 13 pcs) 1-1,5-2-2,5-3-3,5-4-4,5-5-5,5-6-6,5-7	360	235	70
ER16.C.SET10.PWB	426E (ER 16; 10 pcs) 1-2-3-4-5-6-7-8-9-10	360	235	70
ER25.C.SET15.PWB	430E (ER 25; 15 pcs) 2-3-4-5-6-7-8-9-10-11-12-13-14-15-16	360	235	70
ER32.C.SET15.PWB	470E (ER 32; 15 pcs) 3-4-5-6-7-8-9-10-11-12-14-15-16-18-20	360	235	70
ER40.C.SET16.PWB	472E (ER 40; 16 pcs) 4-5-6-7-8-9-10-11-12-14-16-18-20-22-24-26	360	235	70

Note: Collet chucks and wrenches to be ordered separately.

DIN 69871

ISO 60

MAS 403 BT

DIN 2080

HSK-A

VDI

MORSE



ER-C-SET-S-WP

ER SEALED COLLETS FOR CYLINDRICAL SHANK - SETS IN WOODEN PLATE



Application:
For mounting straight-shank tools in
collet chucks DIN 6388/DIN 6499.

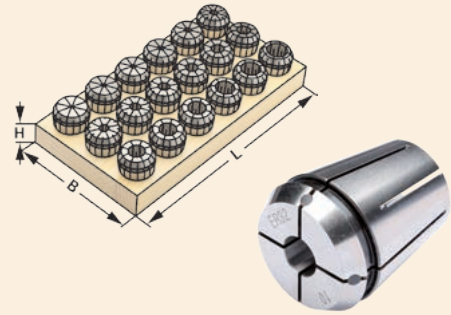

$\nabla \leq 0,015$

Order no.	Size	L	B	H
ER16.C.SET08.S.WP	426EA (ER 16; 8 pcs) 3-4-5-6-7-8-9-10	130	50	25
ER25.C.SET14.S.WP	430EA (ER 25; 14 pcs) 3-4-5-6-7-8-9-10-11-12-13-14-15-16	150	195	25
ER32.C.SET15.S.WP	470EA (ER 32; 15 pcs) 3-4-5-6-7-8-9-10-11-12-14-15-16-18-20	190	150	30
ER40.C.SET16.S.WP	472EA (ER 40; 16 pcs) 4-5-6-7-8-9-10-11-12-14-16-18-20-22-24-26	290	195	25

ER-C-SET-S-WB

ER SEALED COLLETS FOR CYLINDRICAL SHANK - SETS IN WOODEN BOX



Application:
For mounting straight-shank tools in
collet chucks DIN 6388/DIN 6499.

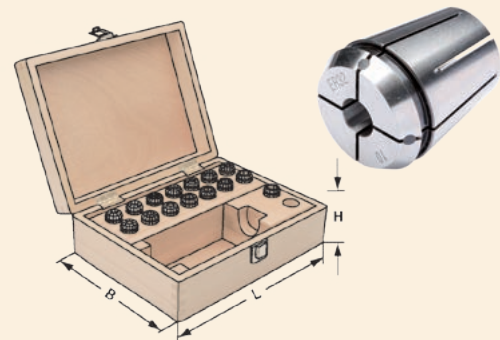

$\nabla \leq 0,015$

Order no.	Size	L	B	H
ER16.C.SET08.S.WB	426EA (ER 16; 8 pcs) 3-4-5-6-7-8-9-10	360	235	70
ER25.C.SET14.S.WB	430EA (ER 25; 14 pcs) 3-4-5-6-7-8-9-10-11-12-13-14-15-16	360	235	70
ER32.C.SET15.S.WB	470EA (ER 32; 15 pcs) 3-4-5-6-7-8-9-10-11-12-14-15-16-18-20	360	235	70
ER40.C.SET16.S.WB	472EA (ER 40; 16 pcs) 4-5-6-7-8-9-10-11-12-14-16-18-20-22-24-26	360	235	70

Note: Collet chucks and wrenches to be ordered separately.



ER-C-SET-SC4-WP

ER SEALED COLLETS WITH 4 COOLANT CHANNELS FOR CYLINDRICAL SHANK - SETS IN WOODEN PLATE



Application:
For mounting straight-shank tools in
collet chucks DIN 6388/DIN 6499.

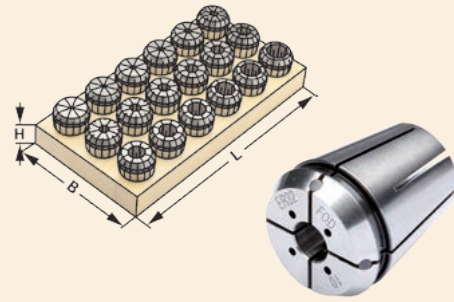

$\nabla \leq 0,015$

Order no.	Size	L	B	H
ER16.C.SET05.SC4.WP	426EC (ER 16; 5 pcs) 3-4-5-6-7	130	50	25
ER25.C.SET12.SC4.WP	430EC (ER 25; 12 pcs) 3-4-5-6-7-8-9-10-11-12-13-14	150	195	25
ER32.C.SET15.SC4.WP	470EC (ER 32; 15 pcs) 3-4-5-6-7-8-9-10-11-12-14-15-16-18-20	190	150	30
ER40.C.SET16.SC4.WP	472EC (ER 40; 16 pcs) 4-5-6-7-8-9-10-11-12-14-16-18-20-22-24-26	290	195	25

ER-C-SET-SC4-WB

ER SEALED COLLETS WITH 4 COOLANT CHANNELS FOR CYLINDRICAL SHANK - SETS IN WOODEN BOX



Application:
For mounting straight-shank tools in
collet chucks DIN 6388/DIN 6499.

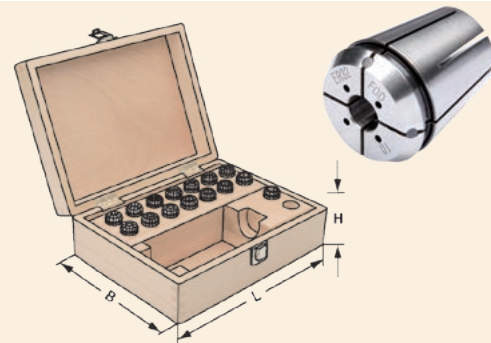

$\nabla \leq 0,015$

Order no.	Size	L	B	H
ER16.C.SET05.SC4.WB	426EC (ER 16; 5 pcs) 3-4-5-6-7	360	235	70
ER25.C.SET12.SC4.WB	430EC (ER 25; 12 pcs) 3-4-5-6-7-8-9-10-11-12-13-14	360	235	70
ER32.C.SET15.SC4.WB	470EC (ER 32; 15 pcs) 3-4-5-6-7-8-9-10-11-12-14-15-16-18-20	360	235	70
ER40.C.SET16.SC4.WB	472EC (ER 40; 16 pcs) 4-5-6-7-8-9-10-11-12-14-16-18-20-22-24-26	360	235	70

Note: Collet chucks and wrenches to be ordered separately.

DIN 69871

ISO 60

MAS 403 BT

DIN 2080

HSK-A

VDI

MORSE



ER-T-SET-WP

ER SEALED COLLETS WITH TAP SQUARE DRIVE - SETS IN WOODEN PLATE

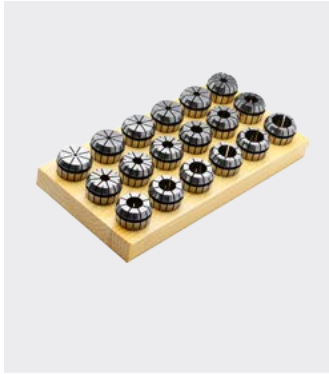

Application:

For machines with rigid tapping.
For safe clamping of taps.

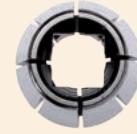
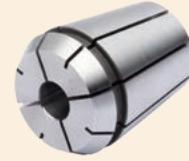
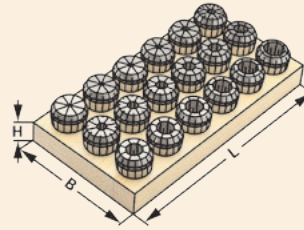

$\nabla \leq 0,015$

Order no.	Size	L	B	H
ER16.T.SET06.WP	426G (ER 16; 6 pcs) 3,5x2,7 - 4,0x3,0 - 4,5x3,4 - 6,0x4,9 - 7,0x5,5 - 8,0x6,2	130	50	25
ER25.T.SET10.WP	430G (ER 25; 10 pcs) 3,5x2,7 - 4,0x3,0 - 4,5x3,4 - 6,0x4,9 - 7,0x5,5 - 8,0x6,2 - 9,0x7,0 - 10,0x8,0 - 11,0x9,0 - 12,0x9,0	150	195	25
ER32.T.SET10.WP	470G (ER 32; 10 pcs) 4,5x3,4 - 6,0x4,9 - 7,0x5,5 - 8,0x6,2 - 9,0x7,0 - 10,0x8,0 - 11,0x9,0 - 12,0x9,0 - 14,0x11,0 - 16,0x12,0	190	150	30
ER40.T.SET11.WP	472G (ER 40; 11 pcs) 6,0x4,9 - 7,0x5,5 - 8,0x6,2 - 9,0x7,0 - 10,0x8,0 - 11,0x9,0 - 12,0x9,0 - 14,0x11,0 - 16,0x12,0 - 18,0x14,5 - 20,0x16,0	290	195	25

DIN 69871

ISO 60

MAS 403 BT

DIN 2080

HSK-A

VDI

MORSE



ER-T-SET-WB

ER SEALED COLLETS WITH TAP SQUARE DRIVE - SETS IN WOODEN BOX



Application:

For machines with rigid tapping.
For safe clamping of taps.

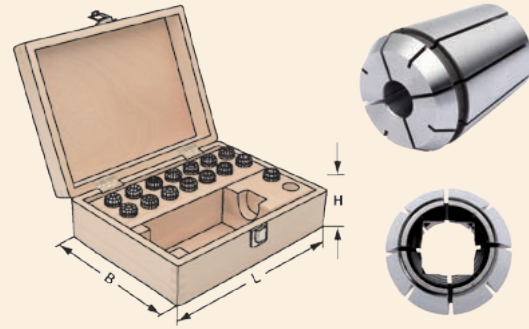

Order no.	Size	L	B	H
ER16.T.SET06.WB	426G (ER 16; 6 pcs) 3,5x2,7 - 4,0x3,0 - 4,5x3,4 - 6,0x4,9 - 7,0x5,5 - 8,0x6,2	360	235	70
ER25.T.SET10.WB	430G (ER 25; 10 pcs) 3,5x2,7 - 4,0x3,0 - 4,5x3,4 - 6,0x4,9 - 7,0x5,5 - 8,0x6,2 - 9,0x7,0 - 10,0x8,0 - 11,0x9,0 - 12,0x9,0	360	235	70
ER32.T.SET10.WB	470G (ER 32; 10 pcs) 4,5x3,4 - 6,0x4,9 - 7,0x5,5 - 8,0x6,2 - 9,0x7,0 - 10,0x8,0 - 11,0x9,0 - 12,0x9,0 - 14,0x11,0 - 16,0x12,0	360	235	70
ER40.T.SET10.WB	472G (ER 40; 11 pcs) 6,0x4,9 - 7,0x5,5 - 8,0x6,2 - 9,0x7,0 - 10,0x8,0 - 11,0x9,0 - 12,0x9,0 - 14,0x11,0 - 16,0x12,0 - 18,0x14,5 - 20,0x16,0	360	235	70

Note: Collet chucks and wrenches to be ordered separately.

DIN 69871

ISO 60

MAS 403 BT

DIN 2080

HSK-A

VDI

MORSE



ER-T-SET-SC4-WP

ER SEALED COLLETS WITH 4 COOLANT CHANNELS AND TAPS SQUARE DRIVE - SETS IN WOODEN PLATE



Application:
For machines with rigid tapping.
For safe clamping of taps.

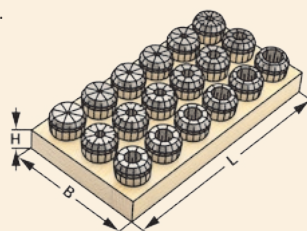

$\nabla \leq 0,015$

Order no.	Size	L	B	H
ER16.T.SET06.SC4.WP	426GC (ER 16; 6 pcs) 3,5x2,7 - 4,0x3,0 - 4,5x3,4 - 6,0x4,9 - 7,0x5,5 - 8,0x6,2	130	50	25
ER25.T.SET10.SC4.WP	430GC (ER 25; 10 pcs) 3,5x2,7 - 4,0x3,0 - 4,5x3,4 - 6,0x4,9 - 7,0x5,5 - 8,0x6,2 - 9,0x7,0 - 10,0x8,0 - 11,0x9,0 - 12,0x9,0	150	195	25
ER32.T.SET10.SC4.WP	470GC (ER 32; 10 pcs) 4,5x3,4 - 6,0x4,9 - 7,0x5,5 - 8,0x6,2 - 9,0x7,0 - 10,0x8,0 - 11,0x9,0 - 12,0x9,0 - 14,0x11,0 - 16,0x12,0	190	150	30
ER40.T.SET11.SC4.WP	472GC (ER 40; 11 pcs) 6,0x4,9 - 7,0x5,5 - 8,0x6,2 - 9,0x7,0 - 10,0x8,0 - 11,0x9,0 - 12,0x9,0 - 14,0x11,0 - 16,0x12,0 - 18,0x14,5 - 20,0x16,0	290	195	25

DIN 69871

ISO 60

MAS 403 BT

DIN 2080

HSK-A

VDI

MORSE



ER-T-SET-SC4-WB

ER SEALED COLLETS WITH 4 COOLANT CHANNELS AND TAPS SQUARE DRIVE - SETS IN WOODEN BOX



Application:

For machines with rigid tapping.
For safe clamping of taps.

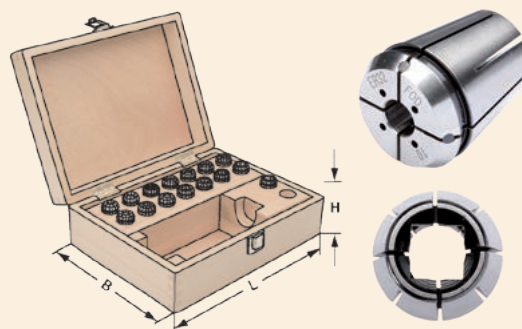

$\nearrow \leq 0,015$

Order no.	Size	L	B	H
ER16.T.SET06.SC4.WB	426GC (ER 16; 6 pcs) 3,5x2,7 - 4,0x3,0 - 4,5x3,4 - 6,0x4,9 - 7,0x5,5 - 8,0x6,2	360	235	70
ER25.T.SET10.SC4.WB	430GC (ER 25; 10 pcs) 3,5x2,7 - 4,0x3,0 - 4,5x3,4 - 6,0x4,9 - 7,0x5,5 - 8,0x6,2 - 9,0x7,0 - 10,0x8,0 - 11,0x9,0 - 12,0x9,0	360	235	70
ER32.T.SET10.SC4.WB	470GC (ER 32; 10 pcs) 4,5x3,4 - 6,0x4,9 - 7,0x5,5 - 8,0x6,2 - 9,0x7,0 - 10,0x8,0 - 11,0x9,0 - 12,0x9,0 - 14,0x11,0 - 16,0x12,0	360	235	70
ER40.T.SET11.SC4.WB	472GC (ER 40; 11 pcs) 6,0x4,9 - 7,0x5,5 - 8,0x6,2 - 9,0x7,0 - 10,0x8,0 - 11,0x9,0 - 12,0x9,0 - 14,0x11,0 - 16,0x12,0 - 18,0x14,5 - 20,0x16,0	360	235	70

Note: Collet chucks and wrenches to be ordered separately.

DIN 69871

ISO 60

MAS 403 BT

DIN 2080

HSK-A

VDI

MORSE



HC-C

HC COLLETS FOR HYDRAULIC CHUCK



Application:
For mounting straight-shank tools.

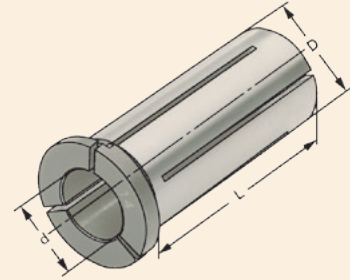

$\nabla \leq 0,005$

Order no.	D	d	L
HC20.C.030	20	3	52,5
HC20.C.040	20	4	52,5
HC20.C.050	20	5	52,5
HC20.C.060	20	6	52,5
HC20.C.080	20	8	52,5
HC20.C.100	20	10	52,5
HC20.C.120	20	12	52,5
HC20.C.140	20	14	52,5
HC20.C.160	20	16	52,5
HC32.C.060	32	6	64,6
HC32.C.080	32	8	64,6
HC32.C.100	32	10	64,6
HC32.C.120	32	12	64,6
HC32.C.140	32	14	64,6
HC32.C.160	32	16	64,6
HC32.C.180	32	18	64,6
HC32.C.200	32	20	64,6
HC32.C.250	32	25	64,6

Note: The chucking diameter is configured for a tool tolerance of h6.

DIN 69871

ISO 60

MAS 403 BT

DIN 2080

HSK-A

VDI

MORSE



HC-C-S

HC COLLETS FOR HYDRAULIC CHUCK - SEALED



Application:

For mounting straight-shank tools with internal coolant.

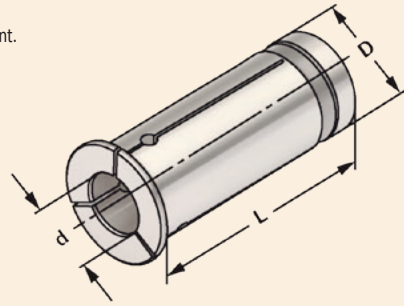

$\nabla \leq 0,005$

Order no.	D	d	L
HC20.C.030.S	20	3	52,9
HC20.C.040.S	20	4	52,9
HC20.C.050.S	20	5	52,9
HC20.C.060.S	20	6	52,9
HC20.C.080.S	20	8	52,9
HC20.C.100.S	20	10	52,9
HC20.C.120.S	20	12	52,9
HC20.C.140.S	20	14	52,9
HC20.C.160.S	20	16	52,9
HC32.C.030.S	32	3	66
HC32.C.040.S	32	4	66
HC32.C.050.S	32	5	66
HC32.C.060.S	32	6	66
HC32.C.080.S	32	8	66
HC32.C.100.S	32	10	66
HC32.C.120.S	32	12	66
HC32.C.140.S	32	14	66
HC32.C.160.S	32	16	66
HC32.C.180.S	32	18	66
HC32.C.200.S	32	20	66
HC32.C.250.S	32	25	66

Note: The chucking diameter is configured for a tool tolerance of h6.

DIN 69871

ISO 60

MAS 403 BT

DIN 2080

HSK-A

VDI

MORSE



QTCW-1

QUICK-CHANGE TAP COLLETS WITHOUT CLUTCH - SIZE 1



Application:

For mounting taps. For right-hand and left-hand threads. Standard type without safety clutch.

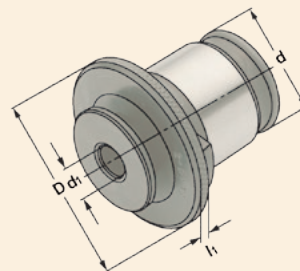

Order no.	D	d	l_1	d_1	□
QTCW.01.035.027	30	19	5	3,5	2,7
QTCW.01.045.034	30	19	5	4,5	3,4
QTCW.01.040.030	30	19	5	4,0	3,0
QTCW.01.060.049	30	19	5	6,0	4,9
QTCW.01.070.055	30	19	5	7,0	5,5
QTCW.01.080.062	30	19	5	8,0	6,2
QTCW.01.090.070	30	19	5	9,0	7,0
QTCW.01.100.080	30	19	5	10,0	8,0
QTCW.01.110.090	30	19	5	11,0	9,0

Note: Quick change adaptors without safety clutch can be interchanged, because only the shaft diameters and the squares must fit.

DIN 69871

ISO 60

MAS 403 BT

DIN 2080

HSK-A

VDI

MORSE



QTCW-2

QUICK-CHANGE TAP COLLETS WITHOUT CLUTCH - SIZE 2



Application:

For mounting taps. For right-hand and left-hand threads. Standard type without safety clutch.

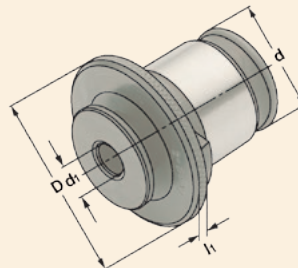

Order no.	D	d	l_1	d_1	□
QTCW.02.060.049	48	31	6	6	4,9
QTCW.02.070.055	48	31	6	7	5,5
QTCW.02.080.062	48	31	6	8	6,2
QTCW.02.090.070	48	31	6	9	7,0
QTCW.02.100.080	48	31	6	10	8,0
QTCW.02.110.090	48	31	6	11	9,0
QTCW.02.120.090	48	31	6	12	9,0
QTCW.02.140.110	48	31	6	14	11,0
QTCW.02.160.120	48	31	6	16	12,0
QTCW.02.180.145	48	31	6	18	14,5

Note: Quick change adaptors without safety clutch can be interchanged, because only the shaft diameters and the squares must fit.

DIN 69871

ISO 60

MAS 403 BT

DIN 2080

HSK-A

VDI

MORSE



QTCW-3

QUICK-CHANGE TAP COLLETS WITHOUT CLUTCH - SIZE 3



Application:

For mounting taps. For right-hand and left-hand threads. Standard type without safety clutch.

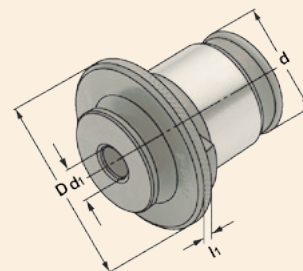

Order no.	D	d	l_1	d_1	□
QTCW.03.110.090	63	48	6	11	9,0
QTCW.03.120.090	63	48	6	12	9,0
QTCW.03.140.110	63	48	6	14	11,0
QTCW.03.160.120	63	48	6	16	12,0
QTCW.03.180.145	63	48	6	18	14,5
QTCW.03.200.160	63	48	6	20	16,0
QTCW.03.220.180	63	48	6	22	18,0
QTCW.03.250.200	63	48	6	25	20,0
QTCW.03.280.220	63	48	6	28	22,0

Note: Quick change adaptors without safety clutch can be interchanged, because only the shaft diameters and the squares must fit.

DIN 69871

ISO 60

MAS 403 BT

DIN 2080

HSK-A

VDI

MORSE



QTCC-1

QUICK-CHANGE TAP COLLETS WITH CLUTCH - SIZE 1



Application:

For mounting taps. For right-hand and left-hand threads. Type with adjustable safety clutch, which prevents the breaking of taps.

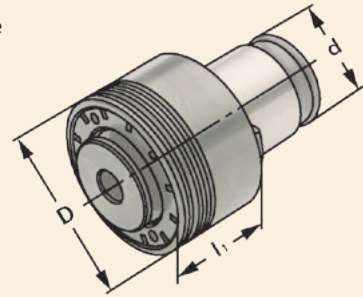

Order no.	D	d	l_1	M	DIN	d_1	□
QTCC.01.035.027	32	19	25	M3	371	3,5	2,7
QTCC.01.040.030	32	19	25	M3,5	371	4,0	3,0
QTCC.01.045.034	32	19	25	M4	371	4,5	3,4
QTCC.01.060.049-M5*	32	19	25	M5	371	6,0	4,9
QTCC.01.060.049-M6**	32	19	25	M6	371	6,0	4,9
QTCC.01.080.062	32	19	25	M8	371	8,0	6,2
QTCC.01.070.055	32	19	25	M10	376	7,0	5,5
QTCC.01.100.080	32	19	25	M10	371	10,0	8,0
QTCC.01.090.070	32	19	25	M12	376	9,0	7,0
QTCC.01.110.090	32	19	25	M14	376	11,0	9,0

* predefined torque for M5.
 ** predefined torque for M6.

Note: Quick change adaptors with safety clutch are supplied with a predefined torque, corresponding to the sizes of the threads.

DIN 69871

ISO 60

MAS 403 BT

DIN 2080

HSK-A

VDI

MORSE



QTCC-2

QUICK-CHANGE TAP COLLETS WITH CLUTCH - SIZE 2



Application:

For mounting taps. For right-hand and left-hand threads. Type with adjustable safety clutch, which prevents the breaking of taps.

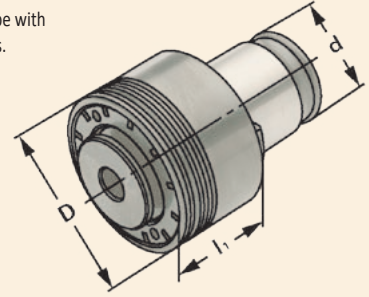

Order no.	D	d	l_1	M	DIN	d_1	□
QTCC.02.060.049-M5*	50	31	31	M5	371	6	4,9
QTCC.02.060.049-M6**	50	31	31	M6	371	6	4,9
QTCC.02.080.062	50	31	31	M8	371	8	6,2
QTCC.02.070.055	50	31	31	M10	376	7	5,5
QTCC.02.100.080	50	31	31	M10	371	10	8,0
QTCC.02.090.070	50	31	31	M12	376	9	7,0
QTCC.02.110.090	50	31	31	M14	376	11	9,0
QTCC.02.120.090	50	31	31	M16	376	12	9,0
QTCC.02.140.110	50	31	31	M18	376	14	11,0
QTCC.02.160.120	50	31	31	M20	376	16	12,0
QTCC.02.180.145	50	31	31	M22	376	18	14,5

* predefined torque for M5.
 ** predefined torque for M6.

Note: Quick change adaptors with safety clutch are supplied with a predefined torque, corresponding to the sizes of the threads.

DIN 69871

ISO 60

MAS 403 BT

DIN 2080

HSK-A

VDI

MORSE



QTCC-3

QUICK-CHANGE TAP COLLETS WITH CLUTCH - SIZE 3



Application:

For mounting taps. For right-hand and left-hand threads. Type with adjustable safety clutch, which prevents the breaking of taps.

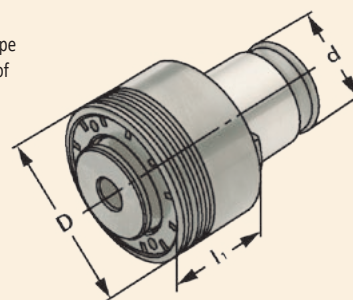

Order no.	D	d	l ₁	M	DIN	d ₁	□
QTCC.03.110.090	72	48	41	M14	376	11	9,0
QTCC.03.120.090	72	48	41	M16	376	12	9,0
QTCC.03.140.110	72	48	41	M18	376	14	11,0
QTCC.03.160.120	72	48	41	M20	376	16	12,0
QTCC.03.180.145-M22*	72	48	41	M22	376	18	14,5
QTCC.03.180.145-M24**	72	48	41	M24	376	18	14,5
QTCC.03.200.160	72	48	41	M27	376	20	16,0
QTCC.03.220.180	72	48	41	M30	376	22	18,0
QTCC.03.250.200	72	48	41	M33	376	25	20,0
QTCC.03.280.220	72	48	41	M36	376	28	22,0

* predefined torque for M22.

** predefined torque for M24.

Note: Quick change adaptors with safety clutch are supplied with a predefined torque, corresponding to the sizes of the threads.

DIN 69871

ISO 60

MAS 403 BT

DIN 2080

HSK-A

VDI

MORSE



QTCR

QUICK-CHANGE TAP COLLETS REDUCTION SLEEVES



Application:

Reducing adaptor for reducing size 3 to 2 and 2 to 1. In this way the clamping ranges can be extended to smaller sizes.

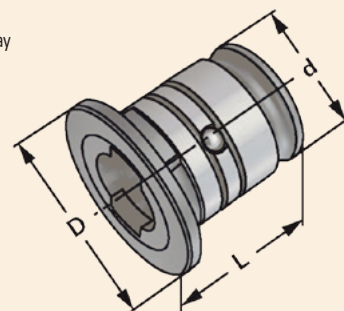

Order no.	holder size	collet size	D	d	L
QTCR.02.01	2	1	48	31	40,4
QTCR.03.02	3	2	59	48	62,6

DIN 69871

ISO 60

MAS 403 BT

DIN 2080

HSK-A

VDI

MORSE



HKS-C

HKS COLLETS FOR HIGH PERFORMANCE CHUCKS



Application:
For mounting straight-shank tools.

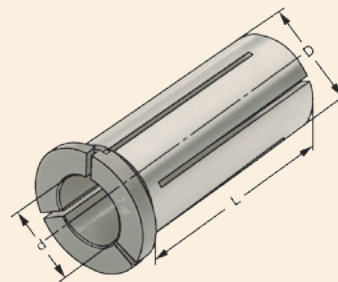

$\nabla \leq 0,005$

Order no.	D	d	L
HKS20.C.060	20	6	52,5
HKS20.C.080	20	8	52,5
HKS20.C.100	20	10	52,5
HKS20.C.120	20	12	52,5
HKS20.C.140	20	14	52,5
HKS20.C.160	20	16	52,5
HKS32.C.060	32	6	64,6
HKS32.C.080	32	8	64,6
HKS32.C.100	32	10	64,6
HKS32.C.120	32	12	64,6
HKS32.C.140	32	14	64,6
HKS32.C.160	32	16	64,6
HKS32.C.180	32	18	64,6
HKS32.C.200	32	20	64,6
HKS32.C.250	32	25	64,6

Note: The chucking diameter is configured for a tool tolerance of h6.

DIN 69871

ISO 60

MAS 403 BT

DIN 2080

HSK-A

VDI

MORSE



HKS-C-S

HKS COLLETS FOR HIGH PERFORMANCE CHUCKS - SEALED



Application:

For mounting straight-shank tools with internal coolant.

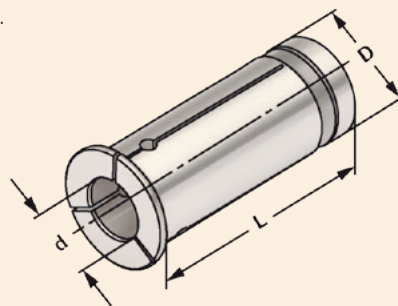

$\nabla \leq 0,005$

Order no.	D	d	L
HKS20.C.030.S	20	3	52,9
HKS20.C.040.S	20	4	52,9
HKS20.C.050.S	20	5	52,9
HKS20.C.060.S	20	6	52,9
HKS20.C.080.S	20	8	52,9
HKS20.C.100.S	20	10	52,9
HKS20.C.120.S	20	12	52,9
HKS20.C.140.S	20	14	52,9
HKS20.C.160.S	20	16	52,9
HKS32.C.030.S	32	3	66
HKS32.C.040.S	32	4	66
HKS32.C.050.S	32	5	66
HKS32.C.060.S	32	6	66
HKS32.C.080.S	32	8	66
HKS32.C.100.S	32	10	66
HKS32.C.120.S	32	12	66
HKS32.C.140.S	32	14	66
HKS32.C.160.S	32	16	66
HKS32.C.180.S	32	18	66
HKS32.C.200.S	32	20	66
HKS32.C.250.S	32	25	66

Note: The chucking diameter is configured for a tool tolerance of h6.

DIN 69871

ISO 60

MAS 403 BT

DIN 2080

HSK-A

VDI

MORSE



N-OZ

CLAMPING NUTS FOR COLLETS - OZ



Application:

All collets with outside form DIN 6388 can be clamped.

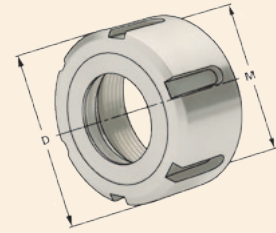

Order no.	Range	D	M
N.OZ16	2 – 16 (OZ 16)	43	M33 × 1,5
N.OZ25	2 – 25 (OZ 25)	60	M48 × 2
N.OZ32	3 – 32 (OZ 32)	72	M60 × 2,5

N-OZ-SR

CLAMPING NUTS FOR COLLETS AND SEALING RING - OZ



Application:

For sealing tools with internal cooling in collet chucks, OZ-system.

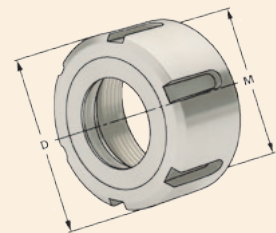

Order no.	Range	D	M
N.OZ16.SR	2 – 16 (OZ 16)	43	M33 × 1,5
N.OZ25.SR	2 – 25 (OZ 25)	60	M48 × 2
N.OZ32.SR	3 – 32 (OZ 32)	72	M60 × 2,5

Note: Sealing discs be ordered separately.

DIN 69871

ISO 60

MAS 403 BT

DIN 2080

HSK-A

VDI

MORSE



SR-OZ

SEALING RINGS FOR COLLETS - OZ



Application:
For sealing tools with internal cooling.

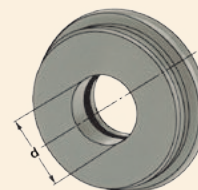

Order no.	Size	d
SR.OZ16.020	OZ 16	2,0
SR.OZ16.025	OZ 16	2,5
SR.OZ16.030	OZ 16	3,0
SR.OZ16.035	OZ 16	3,5
SR.OZ16.040	OZ 16	4,0
SR.OZ16.045	OZ 16	4,5
SR.OZ16.050	OZ 16	5,0
SR.OZ16.055	OZ 16	5,5
SR.OZ16.060	OZ 16	6,0
SR.OZ16.065	OZ 16	6,5
SR.OZ16.070	OZ 16	7,0
SR.OZ16.075	OZ 16	7,5
SR.OZ16.080	OZ 16	8,0
SR.OZ16.085	OZ 16	8,5
SR.OZ16.090	OZ 16	9,0
SR.OZ16.095	OZ 16	9,5
SR.OZ16.100	OZ 16	10,0
SR.OZ16.105	OZ 16	10,5
SR.OZ16.110	OZ 16	11,0
SR.OZ16.115	OZ 16	11,5
SR.OZ16.120	OZ 16	12,0
SR.OZ16.125	OZ 16	12,5
SR.OZ16.130	OZ 16	13,0
SR.OZ16.135	OZ 16	13,5
SR.OZ16.140	OZ 16	14,0
SR.OZ16.145	OZ 16	14,5
SR.OZ16.150	OZ 16	15,0
SR.OZ16.155	OZ 16	15,5
SR.OZ16.160	OZ 16	16,0
SR.OZ25.020	OZ 25	2,0
SR.OZ25.025	OZ 25	2,5
SR.OZ25.030	OZ 25	3,0
SR.OZ25.035	OZ 25	3,5
SR.OZ25.040	OZ 25	4,0
SR.OZ25.045	OZ 25	4,5
SR.OZ25.050	OZ 25	5,0

DIN 69871

ISO 60

MAS 403 BT

DIN 2080

HSK-A

VDI

MORSE



Order no.	Size	d
SR.OZ25.055	OZ 25	5,5
SR.OZ25.060	OZ 25	6,0
SR.OZ25.065	OZ 25	6,5
SR.OZ25.070	OZ 25	7,0
SR.OZ25.075	OZ 25	7,5
SR.OZ25.080	OZ 25	8,0
SR.OZ25.085	OZ 25	8,5
SR.OZ25.090	OZ 25	9,0
SR.OZ25.095	OZ 25	9,5
SR.OZ25.100	OZ 25	10,0
SR.OZ25.105	OZ 25	10,5
SR.OZ25.110	OZ 25	11,0
SR.OZ25.115	OZ 25	11,5
SR.OZ25.120	OZ 25	12,0
SR.OZ25.125	OZ 25	12,5
SR.OZ25.130	OZ 25	13,0
SR.OZ25.135	OZ 25	13,5
SR.OZ25.140	OZ 25	14,0
SR.OZ25.145	OZ 25	14,5
SR.OZ25.150	OZ 25	15,0
SR.OZ25.155	OZ 25	15,5
SR.OZ25.160	OZ 25	16,0
SR.OZ25.165	OZ 25	16,5
SR.OZ25.170	OZ 25	17,0
SR.OZ25.175	OZ 25	17,5
SR.OZ25.180	OZ 25	18,0
SR.OZ25.185	OZ 25	18,5
SR.OZ25.190	OZ 25	19,0
SR.OZ25.195	OZ 25	19,5
SR.OZ25.200	OZ 25	20,0
SR.OZ25.205	OZ 25	20,5
SR.OZ25.210	OZ 25	21,0
SR.OZ25.215	OZ 25	21,5
SR.OZ25.220	OZ 25	22,0
SR.OZ25.225	OZ 25	22,5
SR.OZ25.230	OZ 25	23,0
SR.OZ25.235	OZ 25	23,5
SR.OZ25.240	OZ 25	24,0
SR.OZ25.245	OZ 25	24,5
SR.OZ25.250	OZ 25	25,0
SR.OZ32.030	OZ 32	3,0
SR.OZ32.035	OZ 32	3,5
SR.OZ32.040	OZ 32	4,0
SR.OZ32.045	OZ 32	4,5
SR.OZ32.050	OZ 32	5,0
SR.OZ32.055	OZ 32	5,5
SR.OZ32.060	OZ 32	6,0
SR.OZ32.065	OZ 32	6,5
SR.OZ32.070	OZ 32	7,0
SR.OZ32.075	OZ 32	7,5
SR.OZ32.080	OZ 32	8,0
SR.OZ32.085	OZ 32	8,5
SR.OZ32.090	OZ 32	9,0
SR.OZ32.095	OZ 32	9,5
SR.OZ32.100	OZ 32	10,0

DIN 69871

ISO 60

MAS 403 BT

DIN 2080

HSK-A

VDI

MORSE



Order no.	Size	d
SR.OZ32.105	OZ 32	10,5
SR.OZ32.110	OZ 32	11,0
SR.OZ32.115	OZ 32	11,5
SR.OZ32.120	OZ 32	12,0
SR.OZ32.125	OZ 32	12,5
SR.OZ32.130	OZ 32	13,0
SR.OZ32.135	OZ 32	13,5
SR.OZ32.140	OZ 32	14,0
SR.OZ32.145	OZ 32	14,5
SR.OZ32.150	OZ 32	15,0
SR.OZ32.155	OZ 32	15,5
SR.OZ32.160	OZ 32	16,0
SR.OZ32.165	OZ 32	16,5
SR.OZ32.170	OZ 32	17,0
SR.OZ32.175	OZ 32	17,5
SR.OZ32.180	OZ 32	18,0
SR.OZ32.185	OZ 32	18,5
SR.OZ32.190	OZ 32	19,0
SR.OZ32.195	OZ 32	19,5
SR.OZ32.200	OZ 32	20,0
SR.OZ32.205	OZ 32	20,5
SR.OZ32.210	OZ 32	21,0
SR.OZ32.215	OZ 32	21,5
SR.OZ32.220	OZ 32	22,0
SR.OZ32.225	OZ 32	22,5
SR.OZ32.230	OZ 32	23,0
SR.OZ32.235	OZ 32	23,5
SR.OZ32.240	OZ 32	24,0
SR.OZ32.245	OZ 32	24,5
SR.OZ32.250	OZ 32	25,0
SR.OZ32.255	OZ 32	25,5
SR.OZ32.260	OZ 32	26,0
SR.OZ32.265	OZ 32	26,5
SR.OZ32.270	OZ 32	27,0
SR.OZ32.275	OZ 32	27,5
SR.OZ32.280	OZ 32	28,0
SR.OZ32.285	OZ 32	28,5
SR.OZ32.290	OZ 32	29,0
SR.OZ32.295	OZ 32	29,5
SR.OZ32.300	OZ 32	30,0
SR.OZ32.305	OZ 32	30,5
SR.OZ32.310	OZ 32	31,0
SR.OZ32.315	OZ 32	31,5
SR.OZ32.320	OZ 32	32,0

DIN 69871

ISO 60

MAS 403 BT

DIN 2080

HSK-A

VDI

MORSE



N-ER-M

CLAMPING NUTS MINI FOR COLLETS - ER



Application:
All collets with outside form DIN 6499
(ISO 15488) can be clamped.

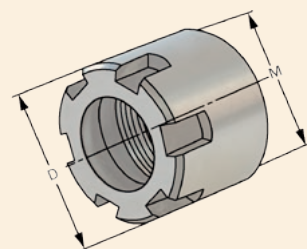

Order no.	Range	D	M
N.ER11.M	1 – 7 (ER 11)	16	M13 × 0,75
N.ER16.M	1 – 10 (ER 16)	22	M19 × 1

N-ER

CLAMPING NUTS FOR COLLETS - ER



Application:
All collets with outside form DIN 6499
(ISO 15488) can be clamped.

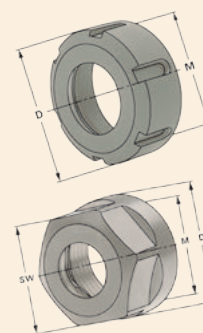

Order no.	Range	D	SW	M
N.ER11.HX17*	1 – 7 (ER 11)	19	17	M14 × 0,75
N.ER16	1 – 10 (ER 16)	32		M22 × 1,5
N.ER16.HX25*	1 – 10 (ER 16)	28	25	M22 × 1,5
N.ER25	2 – 16 (ER 25)	42		M32 × 1,5
N.ER32	2 – 20 (ER 32)	50		M40 × 1,5
N.ER40	3 – 26 (ER 40)	63		M50 × 1,5

* Hexagonal clamping nut

DIN 69871

ISO 60

MAS 403 BT

DIN 2080

HSK-A

VDI

MORSE



N-ER-SR

CLAMPING NUTS FOR COLLETS AND SEALING RING - ER



Application:
For sealing tools with internal cooling in collet chucks, ER-system.

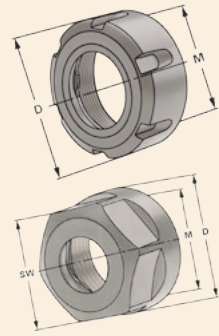

Order no.	Range	D	SW	M
N.ER16.HX25.SR*	1 – 10 (ER 16)	28	25	M22 × 1,5
N.ER25.SR	2 – 16 (ER 25)	42		M32 × 1,5
N.ER32.SR	2 – 20 (ER 32)	50		M40 × 1,5
N.ER40.SR	3 – 26 (ER 40)	63		M50 × 1,5

* Hexagonal clamping nut

Note: **Sealing discs be ordered separately.**

N-ER-SR-SN

CLAMPING NUTS FOR COLLETS AND SEALING RING WITH SPRAY NOZZLES - ER



Application:
For sealing tools with internal cooling in collet chucks, ER-system with spray nozzles.

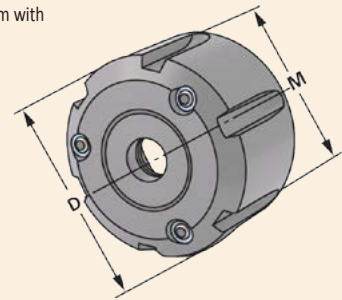

Order no.	Range	D	SW	M
N.ER16.HX25.SR.SN*	1 – 10 (ER 16)	28	25	M22 × 1,5
N.ER25.SR.SN	2 – 16 (ER 25)	42		M32 × 1,5
N.ER32.SR.SN	2 – 20 (ER 32)	50		M40 × 1,5
N.ER40.SR.SN	3 – 26 (ER 40)	63		M50 × 1,5

* Hexagonal clamping nut

Note: **Sealing discs be ordered separately.**

DIN 69871

ISO 60

MAS 403 BT

DIN 2080

HSK-A

VDI

MORSE



SR-ER

SEALING RINGS FOR COLLETS - ER



Application:
For sealing tools with internal cooling.

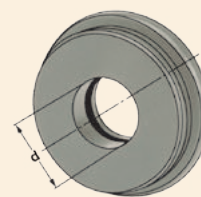

Order no.	Size	d
SR.ER16.010	ER 16	1,0
SR.ER16.015	ER 16	1,5
SR.ER16.020	ER 16	2,0
SR.ER16.025	ER 16	2,5
SR.ER16.030	ER 16	3,0
SR.ER16.035	ER 16	3,5
SR.ER16.040	ER 16	4,0
SR.ER16.045	ER 16	4,5
SR.ER16.050	ER 16	5,0
SR.ER16.055	ER 16	5,5
SR.ER16.060	ER 16	6,0
SR.ER16.065	ER 16	6,5
SR.ER16.070	ER 16	7,0
SR.ER16.075	ER 16	7,5
SR.ER16.080	ER 16	8,0
SR.ER16.085	ER 16	8,5
SR.ER16.090	ER 16	9,0
SR.ER16.095	ER 16	9,5
SR.ER16.100	ER 16	10,0
SR.ER25.010	ER 25	1,0
SR.ER25.015	ER 25	1,5
SR.ER25.020	ER 25	2,0
SR.ER25.025	ER 25	2,5
SR.ER25.030	ER 25	3,0
SR.ER25.035	ER 25	3,5
SR.ER25.040	ER 25	4,0
SR.ER25.045	ER 25	4,5
SR.ER25.050	ER 25	5,0
SR.ER25.055	ER 25	5,5
SR.ER25.060	ER 25	6,0
SR.ER25.065	ER 25	6,5
SR.ER25.070	ER 25	7,0
SR.ER25.075	ER 25	7,5
SR.ER25.080	ER 25	8,0
SR.ER25.085	ER 25	8,5
SR.ER25.090	ER 25	9,0

DIN 69871

ISO 60

MAS 403 BT

DIN 2080

HSK-A

VDI

MORSE



Order no.	Size	d
SR.ER25.095	ER 25	9,5
SR.ER25.100	ER 25	10,0
SR.ER25.105	ER 25	10,5
SR.ER25.110	ER 25	11,0
SR.ER25.115	ER 25	11,5
SR.ER25.120	ER 25	12,0
SR.ER25.125	ER 25	12,5
SR.ER25.130	ER 25	13,0
SR.ER25.135	ER 25	13,5
SR.ER25.140	ER 25	14,0
SR.ER25.145	ER 25	14,5
SR.ER25.150	ER 25	15,0
SR.ER25.155	ER 25	15,5
SR.ER25.160	ER 25	16,0
SR.ER32.010	ER 32	1,0
SR.ER32.015	ER 32	1,5
SR.ER32.020	ER 32	2,0
SR.ER32.025	ER 32	2,5
SR.ER32.030	ER 32	3,0
SR.ER32.035	ER 32	3,5
SR.ER32.040	ER 32	4,0
SR.ER32.045	ER 32	4,5
SR.ER32.050	ER 32	5,0
SR.ER32.055	ER 32	5,5
SR.ER32.060	ER 32	6,0
SR.ER32.065	ER 32	6,5
SR.ER32.070	ER 32	7,0
SR.ER32.075	ER 32	7,5
SR.ER32.080	ER 32	8,0
SR.ER32.085	ER 32	8,5
SR.ER32.090	ER 32	9,0
SR.ER32.095	ER 32	9,5
SR.ER32.100	ER 32	10,0
SR.ER32.105	ER 32	10,5
SR.ER32.110	ER 32	11,0
SR.ER32.115	ER 32	11,5
SR.ER32.120	ER 32	12,0
SR.ER32.125	ER 32	12,5
SR.ER32.130	ER 32	13,0
SR.ER32.135	ER 32	13,5
SR.ER32.140	ER 32	14,0
SR.ER32.145	ER 32	14,5
SR.ER32.150	ER 32	15,0
SR.ER32.155	ER 32	15,5
SR.ER32.160	ER 32	16,0
SR.ER32.165	ER 32	16,5
SR.ER32.170	ER 32	17,0
SR.ER32.175	ER 32	17,5
SR.ER32.180	ER 32	18,0
SR.ER32.185	ER 32	18,5
SR.ER32.190	ER 32	19,0
SR.ER32.195	ER 32	19,5
SR.ER32.200	ER 32	20,0

DIN 69871

ISO 60

MAS 403 BT

DIN 2080

HSK-A

VDI

MORSE



Order no.	Size	d
SR.ER40.010	ER 40	1,0
SR.ER40.015	ER 40	1,5
SR.ER40.020	ER 40	2,0
SR.ER40.025	ER 40	2,5
SR.ER40.030	ER 40	3,0
SR.ER40.035	ER 40	3,5
SR.ER40.040	ER 40	4,0
SR.ER40.045	ER 40	4,5
SR.ER40.050	ER 40	5,0
SR.ER40.055	ER 40	5,5
SR.ER40.060	ER 40	6,0
SR.ER40.065	ER 40	6,5
SR.ER40.070	ER 40	7,0
SR.ER40.075	ER 40	7,5
SR.ER40.080	ER 40	8,0
SR.ER40.085	ER 40	8,5
SR.ER40.090	ER 40	9,0
SR.ER40.095	ER 40	9,5
SR.ER40.100	ER 40	10,0
SR.ER40.105	ER 40	10,5
SR.ER40.110	ER 40	11,0
SR.ER40.115	ER 40	11,5
SR.ER40.120	ER 40	12,0
SR.ER40.125	ER 40	12,5
SR.ER40.130	ER 40	13,0
SR.ER40.135	ER 40	13,5
SR.ER40.140	ER 40	14,0
SR.ER40.145	ER 40	14,5
SR.ER40.150	ER 40	15,0
SR.ER40.155	ER 40	15,5
SR.ER40.160	ER 40	16,0
SR.ER40.165	ER 40	16,5
SR.ER40.170	ER 40	17,0
SR.ER40.175	ER 40	17,5
SR.ER40.180	ER 40	18,0
SR.ER40.185	ER 40	18,5
SR.ER40.190	ER 40	19,0
SR.ER40.195	ER 40	19,5
SR.ER40.200	ER 40	20,0
SR.ER40.205	ER 40	20,5
SR.ER40.210	ER 40	21,0
SR.ER40.215	ER 40	21,5
SR.ER40.220	ER 40	22,0
SR.ER40.225	ER 40	22,5
SR.ER40.230	ER 40	23,0
SR.ER40.235	ER 40	23,5
SR.ER40.240	ER 40	24,0
SR.ER40.245	ER 40	24,5
SR.ER40.250	ER 40	25,0
SR.ER40.255	ER 40	25,5
SR.ER40.260	ER 40	26,0

DIN 69871

ISO 60

MAS 403 BT

DIN 2080

HSK-A

VDI

MORSE



K-HKS

WRENCHES FOR SYSTEM - HKS



Application:
For clamping the HKS collet chucks.

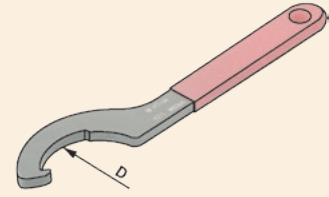

Order no.	Size	D
K.HKS20	HKS 20	53
K.HKS32	HKS 32	68

K-OZ

WRENCHES FOR CLAMPING NUTS - OZ



Application:
For clamping nuts OZ-system.

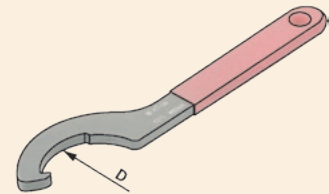

Order no.	Size	D
K.OZ16	2 – 16 (OZ 16)	40
K.OZ25	2 – 25 (OZ 25)	58
K.OZ32	3 – 32 (OZ 32)	68

DIN 69871

ISO 60

MAS 403 BT

DIN 2080

HSK-A

VDI

MORSE



K-ER

WRENCHES FOR CLAMPING NUTS - ER



Application:
For clamping nuts ER-system.

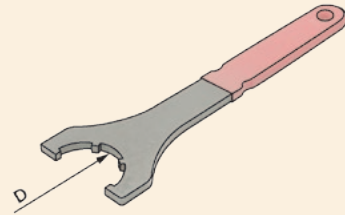

Order no.	Size	D	SW
K.ER11.HX17*	1 – 7 (ER 11)	19	17
K.ER16.HX25*	1 – 10 (ER 16)	28	25
K.ER16.HX27*	1 – 10 (ER 16)	30	27
K.ER16	1 – 10 (ER 16)	32	
K.ER25	2 – 16 (ER 25)	42	
K.ER32	2 – 20 (ER 32)	50	
K.ER40	2 – 26 (ER 40)	63	

* For hexagonal clamping nut

K-ER-M

WRENCHES FOR MINI CLAMPING NUTS - ER



Application:
For mini clamping nuts ER-system.

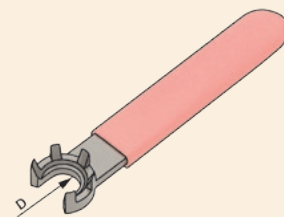

Order no.	Size	D
K.ER11.M	1 – 7 (ER 11)	16
K.ER16.M	1 – 10 (ER 16)	22

DIN 69871

ISO 60

MAS 403 BT

DIN 2080

HSK-A

VDI

MORSE



K-FMH

WRENCHES FOR CLAMPING SCREW FOR HOLDERS FMH



Application:
For retaining screw for FMH holders.

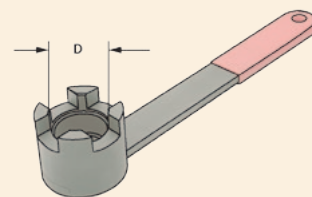

Order no.

D

K.FMH16	16 / M8
K.FMH22	22 / M10
K.FMH27	27 / M12
K.FMH32	32 / M16
K.FMH40	40 / M20

E-MORSE

EXTRACTORS FOR MORSE TAPERS



Application:
For drifting of tools with Morse shanks.

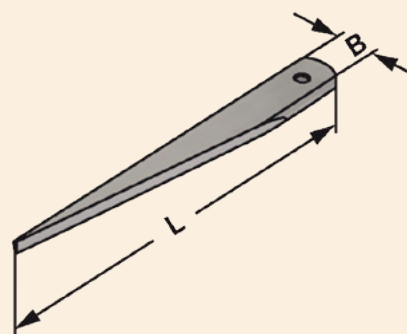

Order no.

MT

L

B

E.MORSE.MT.1-2	1+2	140	20
E.MORSE.MT.3	3	190	25
E.MORSE.MT.4	4	225	30

DIN 69871

ISO 60

MAS 403 BT

DIN 2080

HSK-A

VDI

MORSE



E-HKS

EXTRACTOR FOR COLLETS - HKS



Application:
For extracting the reduction sleeves.

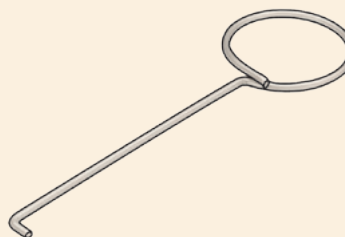

Order no.

Size

E.HKS

HKS 20 / HKS 32

S-FMH

SCREWS FOR SHELL MILL HOLDERS FMH



Application:
Retaining screw for mounting of face mills arbors.

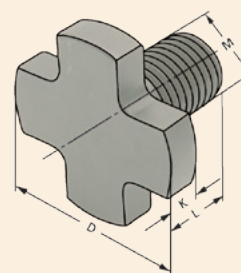

Order no.

Size

M

D

K

L

S.FMH16

16

M8

20

6

16

S.FMH22

22

M10

28

7

18

S.FMH27

27

M12

35

8

22

S.FMH32

32

M16

42

9

26

S.FMH40

40

M20

52

10

30

S.FMH60

60

M30

75

14

45

DIN 69871

ISO 60

MAS 403 BT

DIN 2080

HSK-A

VDI

MORSE



S-FMH-C

SCREWS WITH COOLANT CHANNELS FOR SHELL MILL HOLDERS FMH



Application:

Retaining screw with coolant channels for mounting of face mills arbors.

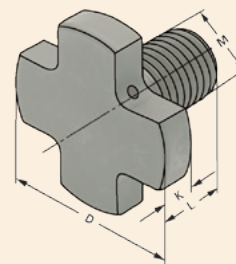

Order no.	Size	M	D	K	L
S.FMH16.C	16	M8	20	6	16
S.FMH22.C	22	M10	28	7	18
S.FMH27.C	27	M12	35	8	22
S.FMH32.C	32	M16	42	9	26
S.FMH40.C	40	M20	52	10	30
S.FMH60.C	60	M30	75	14	45

DIN 69871

ISO 60

MAS 403 BT

DIN 2080

HSK-A

VDI

MORSE



S-W

SCREWS FOR END MILL HOLDERS WELDON



Application:

End mill holders DIN 6359 for Weldon type end mills DIN 1835-B

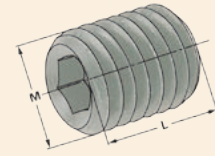

Order no.	M	L	for diameter
S.W.06	M6	10	6
S.W.08	M8	10	8
S.W.10	M10	12	10
S.W.12.14	M12	16	12+14
S.W.16.18	M14	16	16+18
S.W.20	M16	16	20
S.W.25	M18 × 2	20	25
S.W.32	M20 × 2 × 20	20	32
S.W.40	M20 × 2 × 25	25	40

F-FMH2

FEATHER KEY FOR HOLDERS FMH2



Application:

For combi shell mill holders DIN 6358.

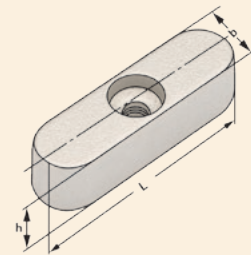

Order no.	h	b	L
F.FMH2.16	4	6	20
F.FMH2.22	6	6	25
F.FMH2.27	7	7	25
F.FMH2.32	8	7	28
F.FMH2.40	10	8	32

DIN 69871

ISO 60

MAS 403 BT

DIN 2080

HSK-A

VDI

MORSE



DR-FMH2

DRIVE RINGS FOR COMBI SHELL MILL HOLDERS FMH2



Application:
For combi shell mill holders DIN 6358.

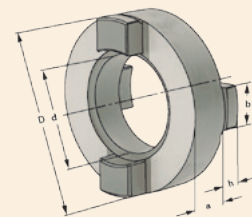

Order no.	d	D	a	b	h
DR.FMH2.16	16	32	10	8	5
DR.FMH2.22	22	40	12	10	5,6
DR.FMH2.27	27	46	12	12	6,3
DR.FMH2.32	32	55	14	14	7
DR.FMH2.40	40	68	14	16	8

DIN 69871

ISO 60

MAS 403 BT

DIN 2080

HSK-A

VDI

MORSE



DS-FMH4

DRIVE SHAFTS FOR DISC MILLING CUTTER ARBORS FMH4



Application:
Drive shafts for disc milling cutter arbors FMH4.

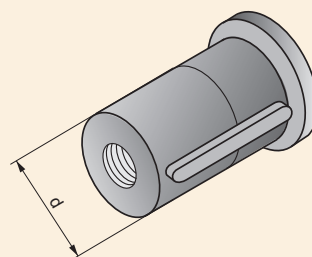

$\nabla \leq 0,015$

Order no.	d
DS.27.FMH4	27
DS.32.FMH4	32
DS.40.FMH4	40
DS.50.FMH4	50
DS.60.FMH4	60

S-DS-FMH4

SREWS FOR DRIVE SHAFTS FOR DISC MILLING CUTTER ARBORS FMH4



Application:
For mounting drive shafts in to disc milling arbors.

Order no.	d
S.DS.27.FMH4	27
S.DS.32.FMH4	32
S.DS.40.FMH4	40
S.DS.50.FMH4	50
S.DS.60.FMH4	60

DIN 69871

ISO 60

MAS 403 BT

DIN 2080

HSK-A

VDI

MORSE



CT-HSK-A

COOLANT TUBE FOR HSK HOLDERS



Application:
For the coolant supply through the centre of HSK toolholders.

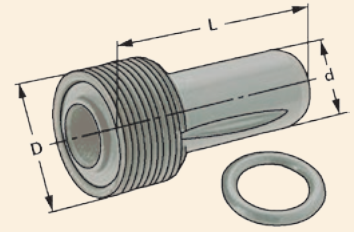

ISO 12164-1

DIN 69893-1

HSK-A

Order no.	Taper	D	d	L
CT.HSK.63A	HSK 63	M18 × 1	12	34,5
CT.HSK.100A	HSK 100	M24 × 1,5	16	44,0

Note: Axial sealed with two O-rings.
After mounting, the coolant tube can be moved only to a minimum degree according to DIN ($\pm 1^\circ$).

K-CT-HSK-A

WRENCH FOR COOLANT TUBE FOR HSK-A HOLDERS



Application:
For mounting the coolant tubes in HSK toolholders.

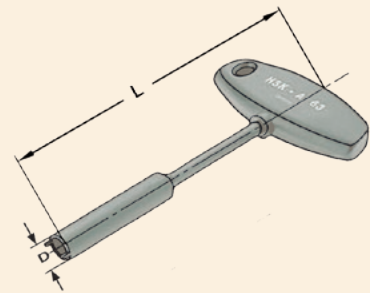

ISO 12164-1

DIN 69893-1

HSK-A

Order no.	Taper	D	L
K.CT.HSK.63A	HSK 63	16,5	136
K.CT.HSK.100A	HSK 100	22,0	136

DIN 69871

ISO 60

MAS 403 BT

DIN 2080

HSK-A

VDI

MORSE



VDI-RS-E2

REDUCTION SLEEVES FOR VDI HOLDERS FORM E2



Application:

Reduction for mounting tools with straight-shank, such as precision boring bars.

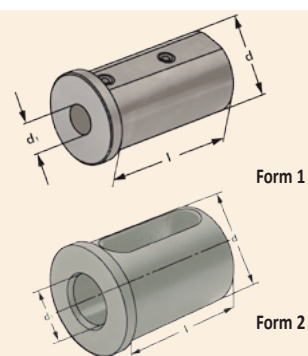

Order no.	form	d	d ₁	l
VDI.RS.E2.25.06	1	25	6	46
VDI.RS.E2.25.08	1	25	8	46
VDI.RS.E2.25.10	1	25	10	46
VDI.RS.E2.25.12	1	25	12	46
VDI.RS.E2.25.14	1	25	14	46
VDI.RS.E2.25.16	2	25	16	46
VDI.RS.E2.25.18	2	25	18	46
VDI.RS.E2.25.20	2	25	20	46
VDI.RS.E2.32.06	1	32	6	56
VDI.RS.E2.32.08	1	32	8	56
VDI.RS.E2.32.10	1	32	10	56
VDI.RS.E2.32.12	1	32	12	56
VDI.RS.E2.32.14	1	32	14	56
VDI.RS.E2.32.16	2	32	16	56
VDI.RS.E2.32.18	2	32	18	56
VDI.RS.E2.32.20	2	32	20	56
VDI.RS.E2.32.25	2	32	25	56
VDI.RS.E2.40.06	1	40	6	71
VDI.RS.E2.40.08	1	40	8	71
VDI.RS.E2.40.10	1	40	10	71
VDI.RS.E2.40.12	1	40	12	71
VDI.RS.E2.40.14	1	40	14	71
VDI.RS.E2.40.16	2	40	16	71
VDI.RS.E2.40.18	2	40	18	71
VDI.RS.E2.40.20	2	40	20	71
VDI.RS.E2.40.25	2	40	25	71
VDI.RS.E2.40.32	2	40	32	71

Note: Suitable for through-coolant (not slotted)

DIN 69871

ISO 60

MAS 403 BT

DIN 2080

HSK-A

VDI

MORSE



VDI-SHIMS

SHIMS FOR VDI HOLDERS



Application:
Shims for VDI toolholder

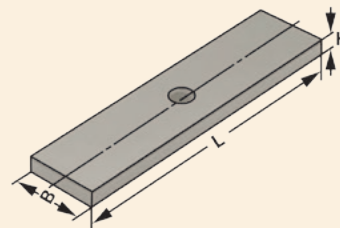

Order no.	B	H	L
VDI.SHIM.18.4.69	18	4	69
VDI.SHIM.22.5.84	22	5	84
VDI.SHIM.25.7.99	25	7	99

VDI-NOZZ

NOZZLES FOR VDI HOLDERS

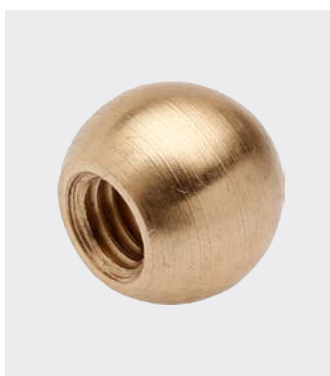

Application:
Sprayer nozzles for cooling by VDI toolholders

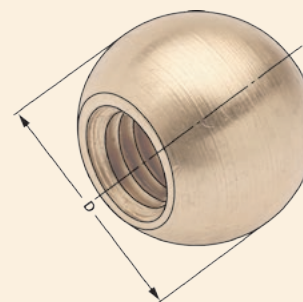

Order no.	D
VDI.NOZZ.08.M	8
VDI.NOZZ.10.M	10
VDI.NOZZ.12.M	12
VDI.NOZZ.14.M	14

DIN 69871

ISO 60

MAS 403 BT

DIN 2080

HSK-A

VDI

MORSE



TW

TAPER WIPERS



Application:
For cleaning internal tapers on machine spindles, sleeves and tool arbors.



Order no.	Size
TW.OZ.16	OZ 16
TW.OZ.25	OZ 25
TW.OZ.32	OZ 32
TW.ER.16	ER 16
TW.ER.25	ER 25
TW.ER.32	ER 32
TW.ER.40	ER 40
TW.MT.1	MK 1
TW.MT.2	MK 2
TW.MT.3	MK 3
TW.MT.4	MK 4
TW.MT.5	MK 5
TW.ISO.30	SK 30
TW.ISO.40	SK 40
TW.ISO.50	SK 50
TW.HSK.63	HSK 63
TW.HSK.100	HSK 100

Version: With parts of leather

DIN 69871

ISO 60

MAS 403 BT

DIN 2080

HSK-A

VDI

MORSE



AB-A360

ASSEMBLY BLOCKS ADJUSTABLE 360 DEGREE



Application:

Hinged mounting device for toolholders. Head turnable for 360°, lockable in different positions.

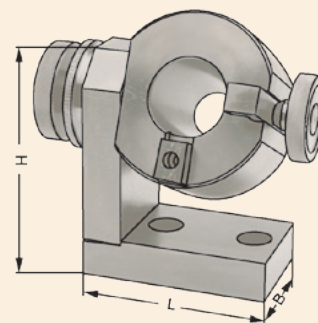

Order no.	Size	L	B	H
AB.A360.ISO.30	SK 30	111	65	134
AB.A360.ISO.40	SK 40	111	65	132
AB.A360.ISO.50	SK 50	111	65	175
AB.A360.HSK.63A	HSK 63	111	65	132
AB.A360.HSK.100A	HSK 100	111	65	132
AB.A360.VDI.30	VDI 30	111	65	132
AB.A360.VDI.40	VDI 40	111	65	132
AB.A360.VDI.50	VDI 50	111	65	132

AB-S90

ASSEMBLY BLOCKS SOLID 90 DEGREE



Application:

Assembly device for vertical and horizontal mounting of tools with steep taper shank.

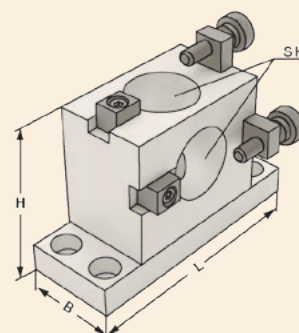

Order no.	Size	L	B	H
AB.S90.ISO.30	SK 30	126	47	75
AB.S90.ISO.40	SK 40	160	60	100
AB.S90.ISO.50	SK 50	180	97	155

DIN 69871

ISO 60

MAS 403 BT

DIN 2080

HSK-A

VDI

MORSE



TECHNICAL PART





Steep Taper 255

Pull studs..... 256

HSK (hollow taper shanks)257 - 258

HSK COOLANT TUBES 259

Effects of imbalance on machine spindles, toolholders and tools.....260 - 261

Hydraulic expansion chucks 262

Operating and user instructions for hydraulic expansion chucks 263

Torques for clamping end-mills in end mill holders DIN 6359 264

Operating and user instructions for CNC-drill chucks 265

Mounting instructions for ER-Collets per DIN STD 6499 266

Mounting instruction for sealing discs 267

Quick-change tapping chucks 268

Instructions for tapping chucks..... 269

Screw taps-shaft size 270

Tool assignment for disc turrets..... 271

High-performance milling chucks HKS-system 273

Product codes description274 - 277

DIN 69871

ISO 60

MAS 403 BT

DIN 2080

HSK-A

VDI

MORSE



STEEP TAPER

Large manual machines and CNC machines use toolholders that have been precisely ground with a male taper that mates with the machine's specific female taper. There is also a way to secure the toolholder in

place with a pull stud or a draw bar thread. With CNC machines, the pull stud is more popular because it allows for easier automatic tool changing.

A toolholder consists of five basic components:

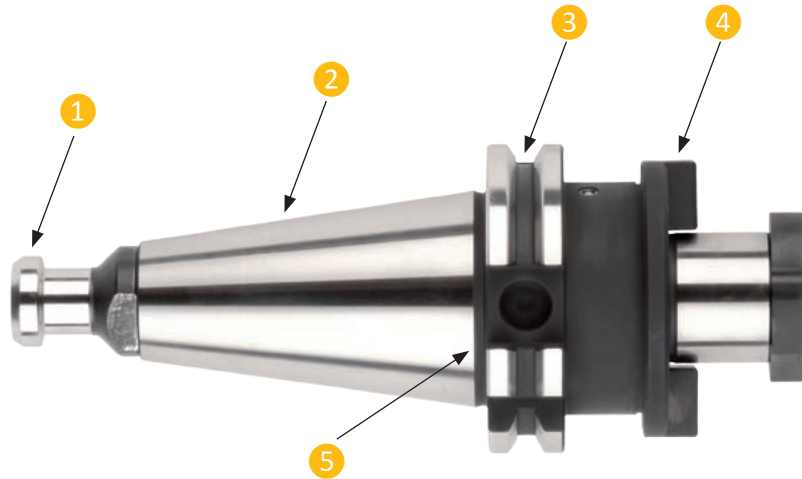

- 1 Pull Stud
- 2 Tapered Shank
- 3 Gripper groove: circular groove
- 4 Adapter
- 5 Opposed Slot

Tapered shank

The standard defines four basic taper shank sizes including SK 30, SK 40, SK 50, and SK 60.

The proper Taper Shank for the Type of Machine

ISO 60 Very large machines

ISO 50 Medium size machines

ISO 40 Small size machines

ISO 30 Very small machines

Coolant supply form AD/B

Toolholders form AD/B have internal coolant supply. To use form B (coolant supply through the collar) the two headless screws must be removed and a sealed pull stud must be inserted. To use form AD (central coolant supply) the two headless screws must remain at the collar and a pull stud with drill through must be inserted.

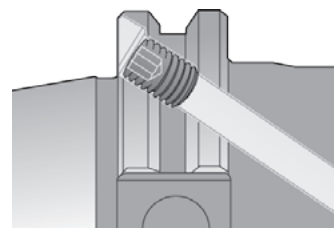

DIN 69871

ISO 60

MAS 403 BT

DIN 2080

HSK-A

VDI

MORSE



PULL STUDS

The pull stud allows the locking draw bar of the spindle to pull the toolholder firmly into the spindle and to release the toolholder automatically.

Pull studs are made in various styles and sizes. They are not necessarily interchangeable.

Only use the pull studs that are specified by the machine tool manufacturer.

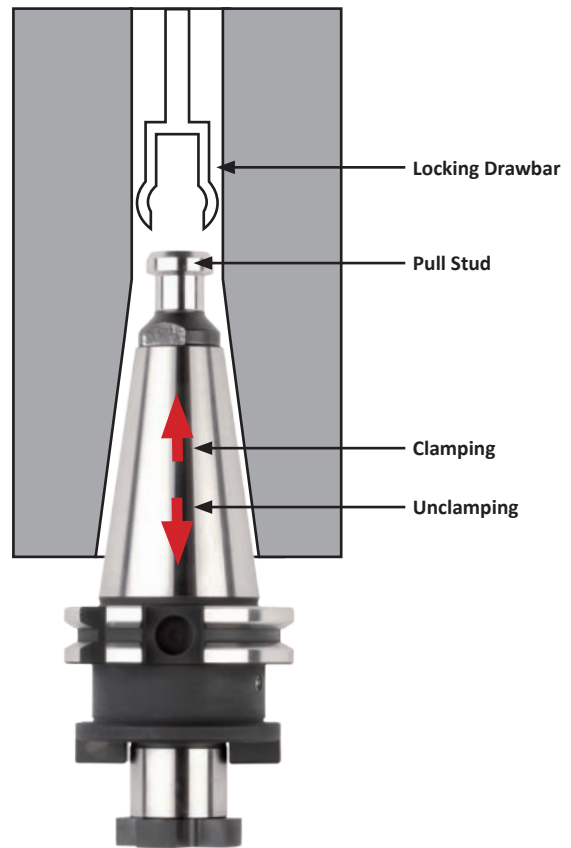

Recommended torque for pull stud tightening:

SK / BT / ISO 30 20~25 Nm
SK / BT / ISO 40 60~80 Nm
SK / BT / ISO 50 200~250 Nm



DIN 69871

ISO 60

MAS 403 BT

DIN 2080

HSK-A

VDI

MORSE



HSK (hollow taper shanks)

HSK-toolholders DIN 69893

The hollow taper shank (HSK) has prevailed since its standardization as an interface between machine and tool.

HSK benefits to the user include:

- High static and dynamic rigidity
- High precision axial and radial reproducibility
- High tool change accuracy and repeatability
- High speed machining performance
- Short tool changing times
- Coding and identification
- Coolant feed

Balancing recommendations and r.p.m. limits

Kemmler HSK-toolholders are generally pre-balanced to G 6.3/15,000 rev./min.
Fine balancing on request is possible.

Because the rotational speed is the largest influencing factor together with the limits regarding the spindle or spindle bearing interface, the following r.p.m. limits for HSK interfaces have been recommended as guidelines within the HSK standards:

HSK-A 63 to 25,000 rev./min
HSK-A 100 to 16,000 rev./min

Depending on the tool, it may be necessary to balance both the tool holder and tool when applying the maximum r.p.m. Exact limits can only be determined if machine and spindle manufacturers are taken into consideration and it is possible to define tools and projecting lengths.

DIN 69871

ISO 60

MAS 403 BT

DIN 2080

HSK-A

VDI

MORSE



HSK (hollow taper shanks)

DIN 69063-1 (ISO 12164-1) Form A

Standard type for machining centres and milling machines. HSK for automatic tool change with gripper groove and index notch. Manual operation is via access hole in taper.

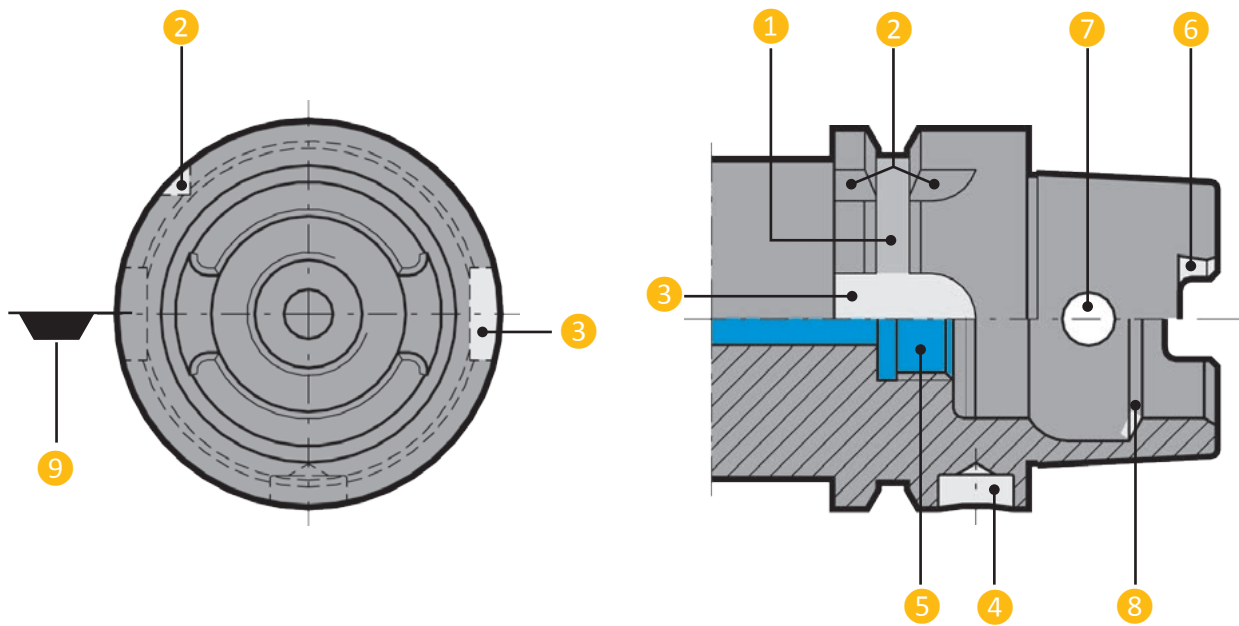
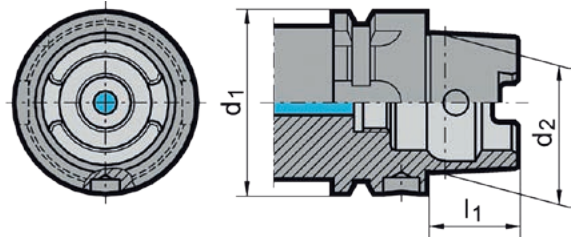

Term definitions of HSK-A interface for automatic tooling systems

- 1 Gripper groove: circular groove
- 2 Index notch: sickle-shaped notch across gripper groove
- 3 Keyway on collar: index notch or for attachment in tool magazine or grippers.
- 4 Coding/identification: bore in collar for attachment of identification system (coding chip)
- 5 Thread for coolant: for attachment of coolant supply set
- 6 Keyway on taper shank: form closed torque transmission to spindle
- 7 Radial bore in taper shank: necessary for manual clamping systems
- 8 Clamping shoulder: circular chamfer for drawing in the tool
- 9 Position of the tool edge of single-edged tools

DIN 69871

ISO 60

MAS 403 BT

DIN 2080

HSK-A

VDI

MORSE



HSK coolant tubes

HSK form A holders must be equipped with a coolant tube.

Using holders without a coolant tube could cause unseen machine spindle damage.

The coolant tube is ideally mounted in vertical direc-

tion – from the bottom to the top. In this manner the sealing ring is prevented from being compressed during location which would cause the loss of its sealing function.

After mounting, the coolant pipe can be moved only to a minimum degree according to DIN ($\pm 1^\circ$).

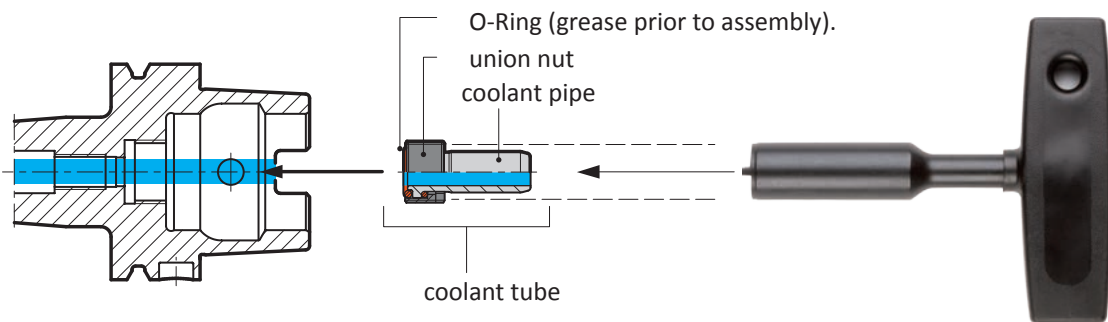

Installation

1. The HSK holder must be clean, free of swarf and undamaged.
2. Grease the O-rings prior to assembly.
3. Centrally insert the complete coolant tube (coolant pipe, union nut and 2 O-rings) in the HSK with the assistance of the socket spanner.
4. Screw in the coolant tube and tighten (see table for torque figures)
5. Check coolant pipe for radial mobility.

Torque figures

for HSK	Mt (Nm)
63	20
100	30

DIN 69871

ISO 60

MAS 403 BT

DIN 2080

HSK-A

VDI

MORSE



Imbalance

An imbalance produces a centrifugal force during the rotation of the spindle impeding the smooth running of the tool. This imbalance influences the working process and the life span of the spindle bearings.

The centrifugal force F increases linear with the imbalance U and squared with the number of revolutions according to the formula below.

Counter balancing

To compensate for unwanted centrifugal forces, the symmetrical distribution of mass must be restored with the aim of eliminating any centrifugal forces influencing the spindle bearing. Tool holders gene-

rally have compensation holes or areas which assist in directing the total amount of all centrifugal forces influencing the axis towards zero (see DIN ISO 1940).

Eccentricity of center of gravity

The imbalance of a spindle causes its center of gravity to deviate a certain distance from the rotating axis in direction of the imbalance. This distance is called

rest-eccentricity e or eccentricity of center of gravity. The heavier the weight of the balance body mass m , the greater the restimbalance U permissible.

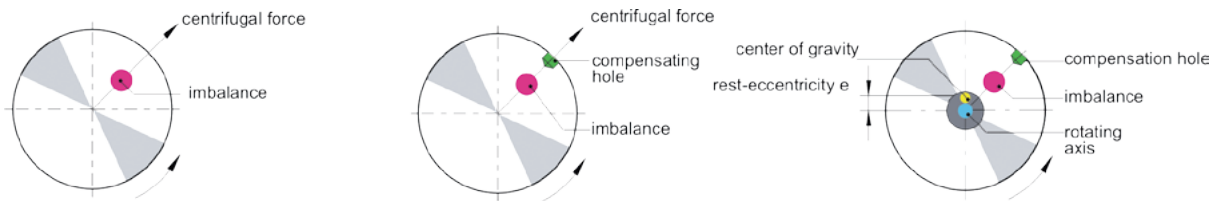

Calculation imbalance

Imbalance is a measure, specifying how much unsymmetrical distributed mass deviates radially from the rotating axis. Imbalance is measured in gmm. The

measure of distance e determines the distance of the center of gravity of an element to the rotating axis.

Imbalance is calculated as follows:

$$U = m \times r$$

U = imbalance in gmm

e = eccentricity of center of gravity in μm

m = mass in kg

Balancing limits

In accordance with DIN ISO 1940 the balance grade is denoted with G as well as the units gmm/kg or μm respectively and is relative to the number of revolutions. At a speed of 15,000 rev./min and a weight of 1 kg, G 6.3 corresponds with a permissible center deviation between rotational axis and center of gravity axis of 4 μm . At twice the speed of 30,000 rev./min it would be 2 μm . If the tool holder was only half the weight, i.e. 0.5 kg, the permissible counter balancing tolerance is also halved. Aim of counter balancing is to find a compromise between the techni-

cally feasible and the economically efficient. Because the radial interchange accuracy for a brand-new HSK holder can be 2 to 3 μm and for an ISO taper shank holder can be 5 to 10 μm , it means an initial quality limit of G 2.5 or G 6.3 respectively at 10,000 rev./min.

The following diagram shows the quality grades to DIN ISO 1940-1, i.e. the permissible rest imbalance in relation to the balance body mass for different counter balance qualities G relative to the maximum operating speed.

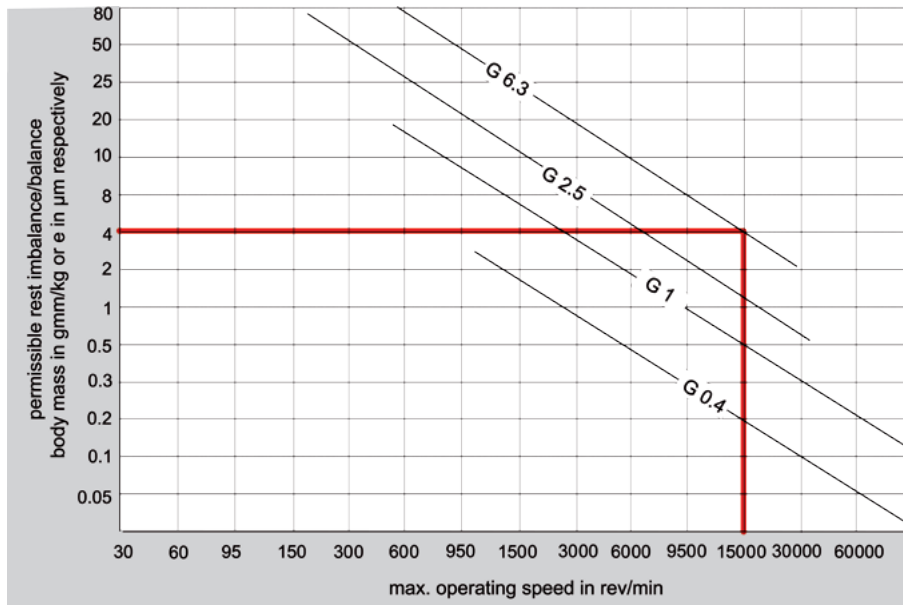

KEMMLER tool holders are balanced to G 6.3/15,000 rev/min.

Fine-balanced with balancing bores in the flange

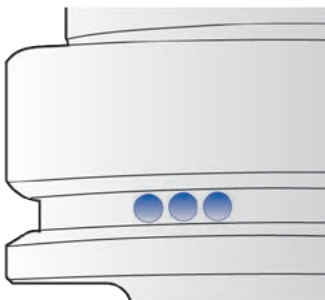

Pre-balanced with balancing bores at the collar

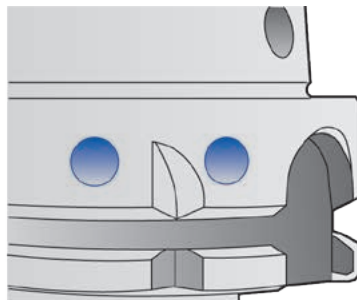

Pre-balanced with balancing flat at the tool body

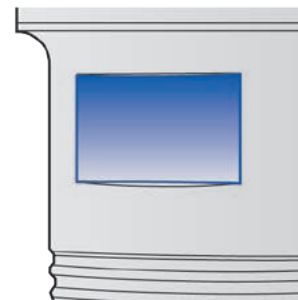

DIN 69871

ISO 60

MAS 403 BT

DIN 2080

HSK-A

VDI

MORSE



HYDRAULIC EXPANSION CHUCKS

Modern machining processes place heavy demands on tool holding. Hydraulic expansion chucks provide excellent clamping characteristics combined with precise concentricity. Furthermore, they enable a simple and fast tool change.

Turning the pressure screw generates sufficient pressure in the pressure chamber resulting in an elastic deformation of the clamping bush, providing power-

ful tool clamping and precise concentricity. A safe and powerful fit is guaranteed.

If reduction sleeves are applied that are able to hold varying tool diameters, the tool application may be extended without problem. If such sleeves are not applied, it is essential to observe the minimum clamping length!

Advantages

- precise tool clamping with a maximum 3 μm deviation from concentricity
- transmission of high torque through (excellent clamping) optimised bush clamping system
- high speed compatibility (no centrifugal forces from clamping segments)
- precise concentricity, therefore excellent surface qualities and dimensional accuracy of the workpiece
- rapid tool change thanks to simple operation of the clamping screw
- optimal tool life
- hydraulic cushioning has vibration absorbing effect

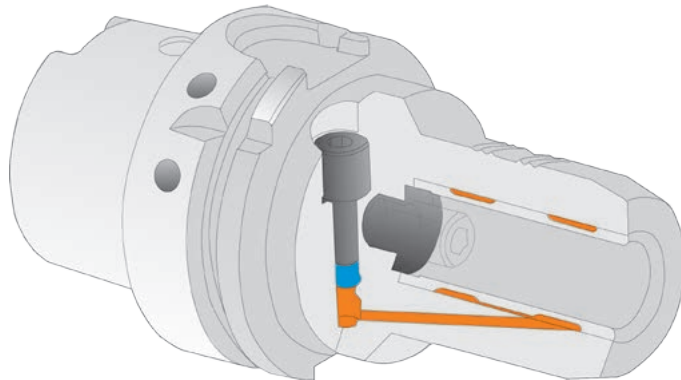

Clamping standard tool shanks to DIN 6535 in hydraulic expansion chucks

Direct clamping of tool preferred
run-out ≤ 0.003 mm

Form HA $\varnothing 6 \dots 32$ mm



Form HB $\varnothing 6 \dots 20$ mm



Clamping of tool shank
only with reduction bushes
run-out ≤ 0.005 mm

Form HB $\varnothing 25 \dots 32$ mm



Form HE $\varnothing 6 \dots 32$ mm



OPERATING AND USER INSTRUCTIONS FOR HYDRAULIC EXPANSION CHUCKS

To ensure a flawless function of the hydraulic expansion chucks, please observe the following instructions:

Usage of straight shank tools according to DIN 1835 and DIN 6535 form (HA) and B (HB) up to \varnothing 20 mm shaft diameter with tolerance h_6 , precision grinded $Ra_{min} = 0.3$.

Shafts according to DIN 6535 form HE (Whistle Notch) can only be clamped by using reduction sleeves. All hydraulic expansion chucks are standard balanced to G 6.3 15,000 rev/min.

Clamping and unclamping the tool

1. Clean the holding fixture bore and the tool shaft of grease and dirt. Insert tools up to the end stop. Observe the minimum clamping depth and the length adjustment range.
2. Clamp the shaft by turning the clamping screw up to the end stop. The tool is clamped. To avoid breaking of the hydraulic sleeve, do not carry out clamping action without a tool.
3. To unclamp the tool, turn the screw approx. 5 to 6 revs. counter clockwise and remove the tool.

Note: Never clamp without a clamped tooling!



DIN 1835 A/DIN 6535 HA



DIN 1835 B/DIN 6535 HB up to \varnothing 20 mm

Cleaning

Attention should be paid to the cleanliness of the holding fixture bore and the tool shaft.

Temperature

Optimal temperature range between 10 – 50°. Do not use with temperatures above 80°.

Storage

Store the hydraulic expansion chuck untensioned, cleaned and lightly oiled.

Clamping shafts

Clamp only tool shafts conforming to the requirements of DIN 1835 form A and form B (up to 20 mm).

Torque

Clamping- \varnothing mm	Moment (Nm)	Tolerance of the tool shaft
6	10	h_6
8	20	h_6
10	40	h_6
12	50	h_6
14	80	h_6
16	100	h_6
18	150	h_6
20	200	h_6
25	250	h_6
32	400	h_6
40	550	h_6



DIN 69871

ISO 60

MAS 403 BT

DIN 2080

HSK-A

VDI

MORSE



TORQUES FOR CLAMPING END-MILLS IN END MILL HOLDERS DIN 6359

Highest concentricity by using defined torques with Weldon shafts:



Torques for DIN 1835

Bore	Screw		Torque
Ø 6 mm	M 6	SW 3	10 Nm
Ø 8 mm	M 8	SW 4	10 Nm
Ø 10 mm	M 10	SW 5	16 Nm
Ø 12 mm	M 12	SW 6	28 Nm
Ø 14 mm	M 12	SW 6	28 Nm
Ø 16 mm	M 14	SW 6	42 Nm
Ø 18 mm	M 14	SW 6	42 Nm
Ø 20 mm	M 16	SW 8	50 Nm
Ø 25 mm	M 18 × 2	SW 10	60 Nm
Ø 32 mm	M 20 × 2	SW 10	72 Nm
Ø 40 mm	M 20 × 2	SW 10	72 Nm
Ø 50 mm	M 24 × 2	SW 12	90 Nm

DIN 69871

ISO 60

MAS 403 BT

DIN 2080

HSK-A

VDI

MORSE



Operating and user instructions for CNC-drill chucks

Use clamping and unclamping of tools

To guarantee error-free function of the CNC-drill chuck 08/ 13/ 16, please follow the next instructions.

Attention:

Clamping or releasing only at standstill of machine spindle or outside the machine.

The CNC-drill chuck (pos. 1) is clamped by means of an Allen-T-wrench (pos. 3) on side of the drill chuck actuating a bevel gear. Turn the Allen-T-wrench counter clockwise to open the drill chuck, clockwise to close it.

1st step

Open the jaw of the drill chuck wide enough to insert the cutting tool. (pos. 2)

2nd step

Fit cutting tool (pos. 2) to the stud into the CNC-drill chuck (pos. 1) so that the tool shank is fit closely to the whole length of the clamping jaws. (picture 1)

3rd step

Turn the Allen-T-wrench (pos. 3) clockwise to clamp the cutting tool using the torque mentioned in the table to clamp the tool properly. (picture 2)

Note:

Do not use any kind of extensions for clamping. By using a torque higher than mentioned in our table the bevel gear can be damaged. In this case the bevel pinion will be the rated break point to protect the drill chuck against damage.

4th step

Test the concentricity after clamping and make sure that the tool is clamped safely.

Note:

Do not clamp tools with tapered shafts.

5th step

The CNC-drill chuck is ready for work and can be clamped into the machine spindle. (picture 3)

6th step

To release the cutting tool please turn the Allen-T-wrench counter clockwise and remove the cutting tool. (picture 3)

Maintenance and Cleaning

The CNC-drill chucks 08 / 13 / 16 are maintenance-free.

The CNC-drill chucks 08 / 13 / 16 should be cleaned after use with a clean cloth to prevent corrosions.

Before storing the drill chucks please spray oil on the surface to prevent corrosion.

Repair

In case of a damage of the CNC-drill chuck, please send it back to us. We will principally exchange the complete drill chuck head.

With this procedure you will get the quickest possible a replacement and only on this way a proper function and a run-out accuracy of < 0.03 mm can be guaranteed.



picture 1



picture 2



picture 3

DIN 69871

ISO 60

MAS 403 BT

DIN 2080

HSK-A

VDI

MORSE



Assembling instructions:

Insert groove of collet into eccentric ring of the clamping nut at the mark on the bottom of the nut. Push collet in the direction of the arrow until it clicks in place. Screw nut with collet onto toolholder. We recommend to tighten the nut with a torque wrench.

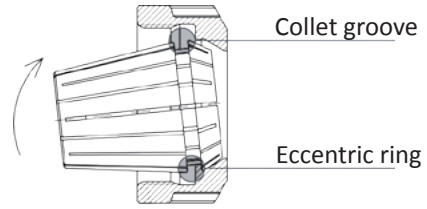

Disassembling instructions:

After the nut is unscrewed from the toolholder, press on the face of the collet while simultaneously pushing sideways on the back of the collet until it disengages from the clamping nut.

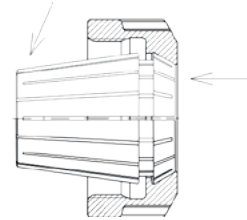

Improper assembly can permanently destroy the concentricity of the collet and may result in a damaged clamping nut.

Note:

Only mount nuts with correctly inserted collets! Never place the collet into the holder without first assembling it into the nut.

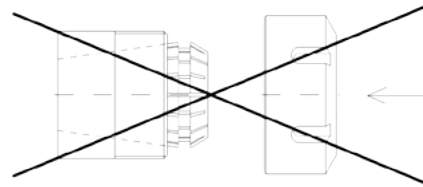

Never clamp oversize tool shanks! e.g. never use a \varnothing 12–11 mm collet to clamp a \varnothing 12.2 mm shank. Rather use the next bigger collet (here \varnothing 13–12 mm collet).

Insert tool the full length of the collet for best results if possible. However, never insert tool less than 2/3 of the collet bore length. Improper tool insertion can permanently deform the collet and will result in poor runout.

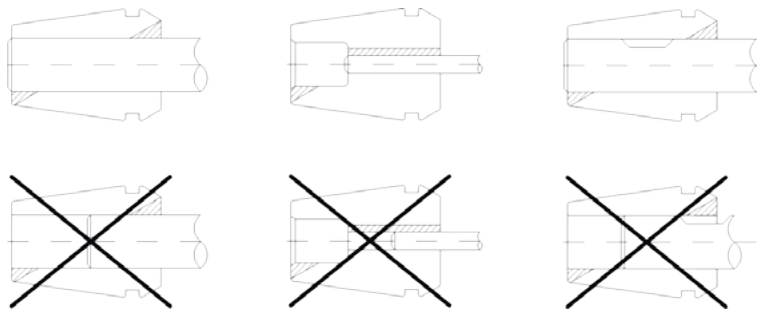

Maximum torque

ER 16	M22 × 1.5	70 Nm
ER 25	M32 × 1.5	130 Nm
ER 32	M40 × 1.5	170 Nm
ER 40	M50 × 1.5	220 Nm

Please observe the maximum torque indicated in the chart!

DIN 69871

ISO 60

MAS 403 BT

DIN 2080

HSK-A

VDI

MORSE



MOUNTING INSTRUCTION FOR SEALING DISCS

Assembly

Insert the small diameter of the disc into the centre of the coolant nut and apply even pressure until the disc is properly seated into the nut. The disc must be flush with the outside of the nut.

Removal

To remove the disc, simply press on the outside of the disc evenly, until it snaps out.

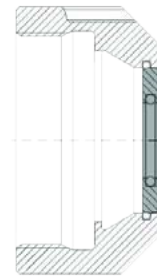
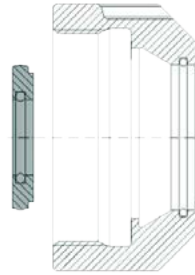

DIN 69871

ISO 60

MAS 403 BT

DIN 2080

HSK-A

VDI

MORSE



QUICK-CHANGE TAPPING CHUCKS

The process of tapping is a complex balance of rotational and axial movements of the tool. It is sometimes necessary to restrict the axial movements of the tool. If the axial movement is not accurately controlled,

the leading or trailing flanks of the tap may be forced to progressively “shave” one flank of the component thread, thus producing a thin and oversize thread in the component.

Tension – forward float capability allows the tap to progress into the component without interference from the axial feed of the machine spindle.



Compression – backward float capability, acts as a cushion and allows the tap to commence cutting at its own axial feed independent of the machine spindle.



Compression/Tension – float is designed to negate any external forces during the machining operation.



Radial float – allows for slight misalignment of the machine spindle axis and hole axis prior to tapping. This is not recommended manufacturing practice and should be avoided.



DIN 69871

ISO 60

MAS 403 BT

DIN 2080

HSK-A

VDI

MORSE



INSTRUCTIONS FOR TAPPING CHUCKS

For a correct use of the tapping chuck, please check, during the first thread, not to exceed the max.

axial stroke of the compensation values. This is to avoid damaging the thread or the tapping chuck.



Order No.	Tap collets	Length adjustment in mm on	
		Compression	Extension
XXX-QTCC.M3.M14	QTCC.01.XXX / QTCW.01.XXX	7	7
XXX-QTCC.M5.M22	QTCC.02.XXX / QTCW.02.XXX	12	12
XXX-QTCC.M14.M36	QTCC.03.XXX / QTCW.03.XXX	17,5	17,5

DIN 69871

ISO 60

MAS 403 BT

DIN 2080

HSK-A

VDI

MORSE



SCREW TAPS-SHAFT SIZE

Shaft diameter	DIN 352	DIN 5157	DIN 371	DIN 374	DIN 376
Ø x □					
Ø 2.5 × 2.1 □	M1		M1	M3	M3.5
Ø 2.5 × 2.1 □	M1.1		M1.1	M3.5	
Ø 2.5 × 2.1 □	M1.2		M1.2		
Ø 2.5 × 2.1 □	M1.4		M1.4		
Ø 2.5 × 2.1 □	M1.6		M1.6		
Ø 2.5 × 2.1 □	M1.8		M1.8		
Ø 2.8 × 2.1 □	M2		M2	M4	M4
Ø 2.8 × 2.1 □	M2.2		M2.2		
Ø 2.8 × 2.1 □	M2.5		M2.5		
Ø 3.5 × 2.7 □	M3		M3	M5	M5
Ø 4 × 3 □	M3.5		M3.5		
Ø 4.5 × 3.4 □	M4		M4	M6	M6
Ø 6 × 4.9 □	M5		M5		
Ø 6 × 4.9 □	M6		M6		
Ø 6 × 4.9 □	M8			M8	M8
Ø 7 × 5.5 □	M10	G 1/8"		M10	M10
Ø 8 × 6.2 □			M8		
Ø 9 × 7 □	M12			M12	M12
Ø 10 × 8 □			M10		
Ø 11 × 9 □	M14	G 1/4"		M14	M14
Ø 12 × 9 □	M16	G 3/8"		M16	M16
Ø 14 × 11 □	M18			M18	M18
Ø 16 × 12 □	M20	G 1/2"		M20	M20
Ø 18 × 14.5 □	M22	G 5/8"		M22	M22
Ø 18 × 14.5 □	M24			M24	M24
Ø 20 × 16 □	M27	G 3/4"		M27	M27
Ø 22 × 18 □	M30	G 7/8"		M30	M30
Ø 25 × 20 □	M33	G 1		M33	M33
Ø 28 × 22 □	M36	G 1 1/8"		M36	M36
Ø 32 × 34 □	M39	G 1 1/4"		M39	M39
Ø 32 × 24 □	M42			M42	M42
Ø 36 × 29 □	M45	G 1 3/8"		M45	M45
Ø 36 × 29 □	M48	G 1 1/2"		M48	M48
Ø 36 × 29 □		G 1 3/4"			
Ø 36 × 29 □		G 2"			



TOOL ASSIGNMENT FOR DISC TURRETS

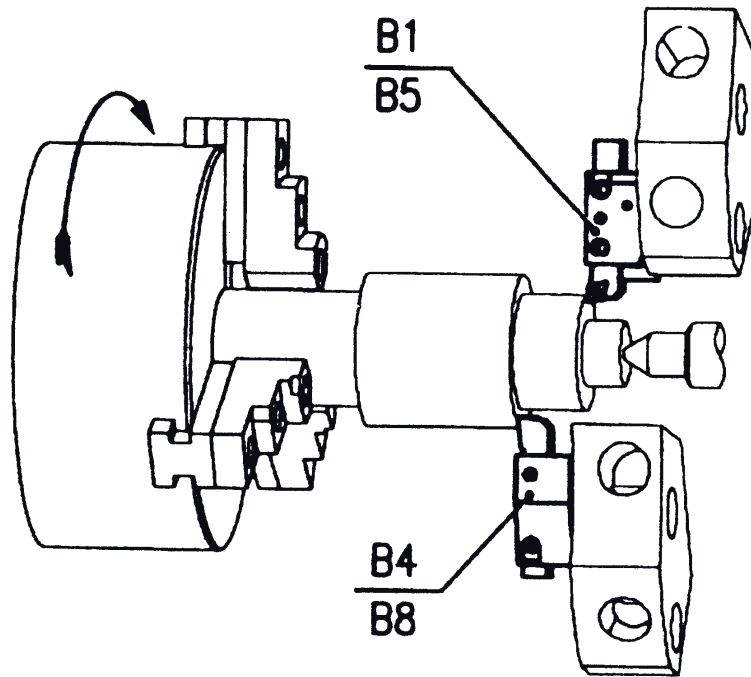

Application of radial tool holders with counter clockwise spindle rotation

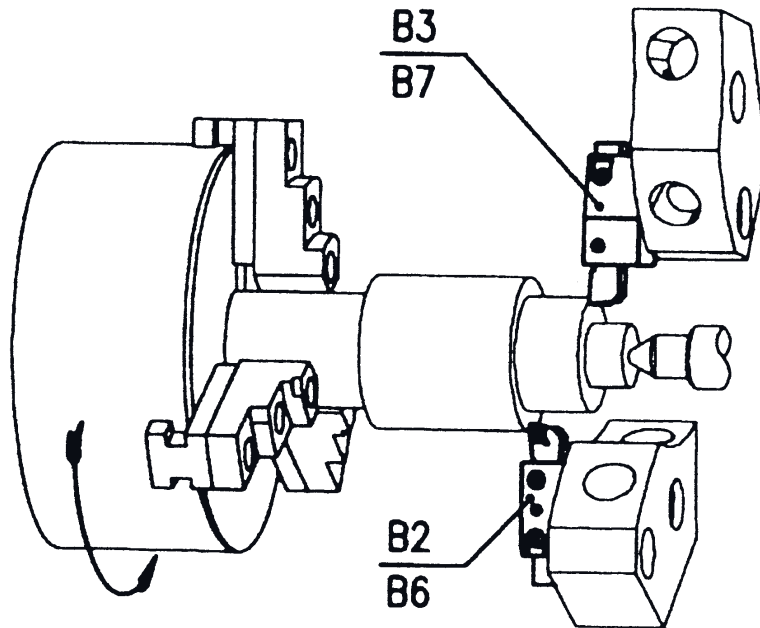

Application of radial tool holders with clockwise spindle rotation

DIN 69871

ISO 60

MAS 403 BT

DIN 2080

HSK-A

VDI

MORSE



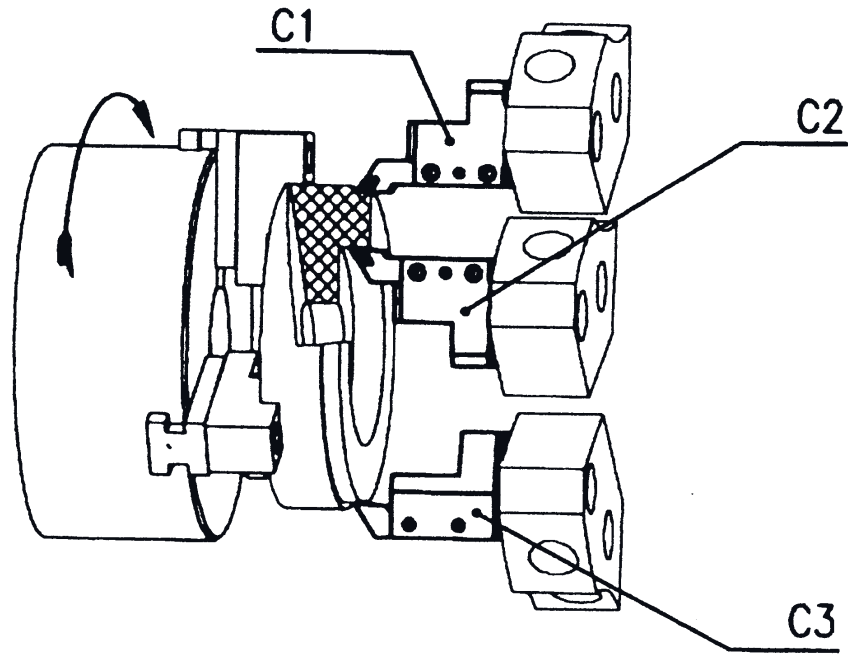

Application of axial tool holders with counter clockwise spindle rotation

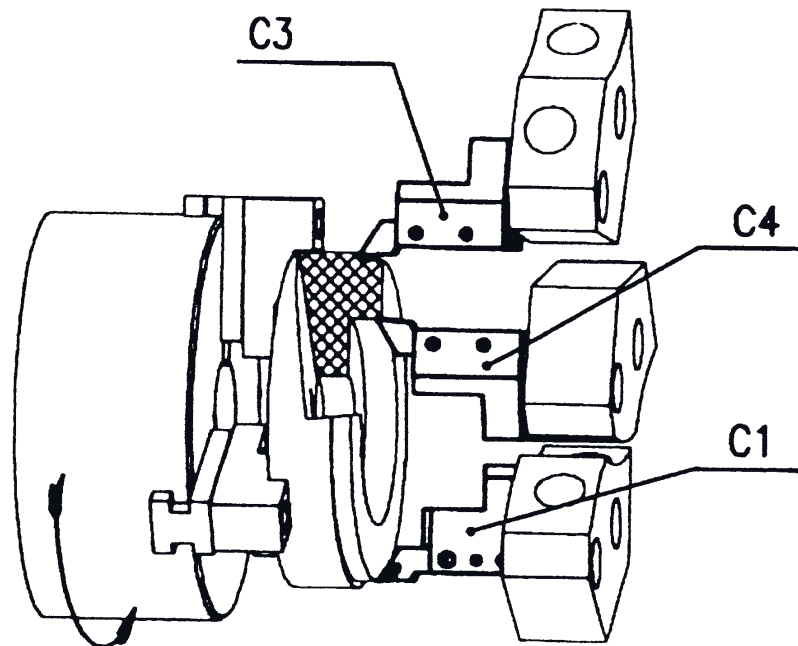

Application of axial tool holders with clockwise spindle rotation

HIGH-PERFORMANCE MILLING CHUCKS HKS-SYSTEM

The high-performance milling chucks are suitable for almost all applications.

Especially in heavy roughing we guarantee unsurpassed high clamping forces and high process reliability. HKS power chucks lead through the rigidity of the

chuck, its concentricity and clamping even at 3 mm from nose lining to excellent surface finish and high tool life.

All HKS chucks grant a maximum deviation of concentricity of 3 μm at 3 x D.

Application:

- heavy roughing
- finish milling
- hard milling
- drilling, reaming
- thread milling

Concentricity:

Max. deviation of concentricity 3 μm at 3 x D of the clamped tool..

Balancing:

Standard fine-balanced (G 6,3 15.000 min⁻¹).

Clamping shank:

All available tool shanks with or without Weldon shank can be clamped directly or with an adapter sleeve.

Size	20mm	25mm
Clamping torque	50-70 Nm	80-100 Nm
Clamping force	780 Nm	2000 Nm



DIN 69871

ISO 60

MAS 403 BT

DIN 2080

HSK-A

VDI

MORSE



PRODUCT CODES DESCRIPTION

Rotating tool-holders

69871 . 40ADB – CCM . ER16 . 160

DESIGN

- 69871** - DIN 69871
- 2080** - DIN 2080
- BT** - MAS 403 BT = JIS B 6399
- HSK** - DIN 69893 = ISO 12164-1
- VDI** - DIN 69880 = ISO 10889-1
- MORSE** - DIN 228 = ISO 296
- AC** - adaptors with cylindrical shank
- ACF** - adaptors with cylindrical shank and flat clamping surface
- AW** - adaptors with Weldon shank

SIZE AND VERSION

xx= size

ISO Cone versions

- xxA - without internal coolant
- xxAD - central coolant supply
- xxADB - coolant through the collar and central supply

HSK cone

- xxA - HSK type A for automatic tool change with gripper groove and index notch

Morse

- MT.x - Morse taper with tang
- MTS.x - Morse taper with drawbar thread

TYPE

- BLA** - blanks for special holders
- CC** - collet chucks
- CCM** - mini collet chucks
- DC** - drill chuck holders
- FMH1** - shell mill holders
- FMH2** - combi shell mill holders
- FMH4** - holders for disc milling cutters
- HC** - hydraulic chucks
- IHA** - holders for milling cutters with threaded end (exchangeable head)
- MT** - holders for morse taper
- MTS** - holders for morse taper with drawbar thread
- QTCC** - quick-change tapping chucks with compensation
- QTCW** - quick-change tapping chucks without compensation
- RED** - reductions
- SC** - shrink fit holders
- TA** - test arbors
- W** - Weldon end mill holders

Characteristic data for different types of holders

- BLA and TA** - diameter / lengths A
- CC and CCM** - collet type and size / lengths A
- DC** - max. diameter of tool shaft / lengths A
- FMH1 and FMH2** - pilot diameter size / lengths A
- FMH4** - driving shaft diameter / lengths A
- HC and SC and W** - diameter of tool shaft / lengths A
- IHA** - internal thread size / lengths L
- MT and MTS** - Morse taper size / lengths A
- QTCC and QTCW** - range of thread size
- RED** - type and size of cone

Variant descriptions

- *.C – with coolant channels
- *.HX – with hexagonal nut
- * - represents previous signs in product description

DIN 69871

ISO 60

MAS 403 BT

DIN 2080

HSK-A

VDI

MORSE



PRODUCT CODES DESCRIPTION

Turning tool-holders VDI

VDI . 40 – B1 . 25 . 44

DESIGN

VDI - DIN 69880 = ISO 10889-1

SIZE

XX - shank dimension

Characteristic data for different types of holders

- A1** - the dimensions of the cuboids
 - A2** - diameter / lengths
 - AL** - height of the blade for parting & grooving
 - AR** - height of the blade for parting & grooving
 - Bx** - height of the tool shank / the distance from the front of the turret
 - Cx** - height of the tool shank
 - Dx** - height of the tool shank
 - DC** - max. diameter of tool shaft / the distance from the front of the turret
 - E1** - diameter of drill shaft
 - E2** - diameter of boring bars
 - E3** - size of OZ collets
 - E4** - size of ER collets
 - F1** - Morse taper size
 - HC** - diameter of tool shaft / the distance from the front of the turret
 - QTCC** - range of thread size
 - QTCW** - range of thread size
 - TA** - diameter and length
 - Z2** - variants
- Variant descriptions
- *.C** - with coolant channels
 - *.P** - VDI plugs made from plastic
 - *.S** - VDI plugs made from steel
 - *** - represents previous signs in product description

TYPE

- | | |
|--|--|
| A1 - blanks form A1 | C3 - axial holders form C3 - upside-down
- right - short |
| A2 - blanks form A2 | C4 - axial holders form C4 - upside-down
- left - short |
| AL - parting-off holders form AL - left
- adjustable height | D1 - multiple seats holders form D1 |
| AR - parting-off holders form AR - right
- adjustable height | D2 - multiple seats holders form D2 - upside-down |
| B1 - radial holders form B1 - right - short | DC - drill chuck holders |
| B2 - radial holders form B2 - left - short | DC - drill chuck holders with coolant nozzles |
| B3 - radial holders form B3 upside-down
- right - short | E1 - holders form E1 for drills with indexable inserts |
| B4 - radial holders form B4 upside-down
- left - short | E2 - holders form E2 for boring bars |
| B5 - radial holders form B5 - right - long | E3 - collet chuck holders form E3 - oz collet |
| B6 - radial holders form B6 - left - long | E4 - collet chuck holders form E4 - er collet |
| B7 - radial holders form B7 - upside-down
- right - long | F1 - holders form F1 for morse taper |
| B8 - radial holders form B8 - upside-down
- left - long | HC - hydraulic chucks |
| C1 - axial holders form C1 - right | QTCC - quick-change tapping chucks with
compensation |
| C2 - axial holders form C2 - left | QTCW - quick-change tapping chucks without
compensation |
| | TA - test arbors |
| | Z2 - protection plugs form Z2 |

DIN 69871

ISO 60

MAS 403 BT

DIN 2080

HSK-A

VDI

MORSE



PRODUCT CODES DESCRIPTION

Accessories for collets chucks

ER16 . C.SET05 . SC4 . WB
QTCW.01 . 035.027

COLLETS DESIGN and SIZE

ERxx - ER collets / size
OZxx - OZ collets / size
HKSxx - HKS collets for high performance chucks / size
HCxx - HC collets / size
QTCR.xx - quick-change tap collets reduction sleeves / size
QTCC.xx - quick-change tap collets with clutch /size
QTCW.xx - quick-change tap collets without clutch / size

Collet variants

P - precision
S - sealed
SC4 - sealed with 4 coolant channels

SET variants

WP - wooden plate
WB - wooden box

INTERNAL SHAPE and SIZE

C - for tools with cylindrical shaft
xx - shaft diameter
SETxx - SET of collets with quantity number
T - for taps with square drive
xxx.xxx - cylindrical tap diameter / square size (in tenths of millimeter)
SETxx - SET of collets with quantity number

N . ER16 . HX25 . SR . SN

TYPE OF ACCESSORY FOR COLLETS

N.ERxx - nuts for collet chucks ER
N.OZxx - nuts for collet chucks OZ
N.HKSxx - nuts for collet chucks HKS
SR.ER xx - sealing rings for collets - ER
SR.OZxx - sealing rings for collets – OZ
K.xxxx - wrenches (keys) for clamping nuts / type and size
K.xxxx.M - wrenches (keys) for MINI clamping nuts / type and size
E.HKS - extractor for HKS collets

VARIANTS

M - mini nuts
HXxx - hexagonal nuts / size
SR - for sealing rings
SN - with spray nozzles

DIN 69871

ISO 60

MAS 403 BT

DIN 2080

HSK-A

VDI

MORSE



Accessories for other holders

TYPE OF ACCESSORIES	CHARACTERISTIC DATA
<p>PS.2080.xx - pull studs DIN 2080 PS.69872.xx - pull studs DIN 69872 PS.7388.xx - pull studs DIN 7388 PS.BT.xx - pull studs MAS 403 BT K.FMHxx - wrenches (keys) for clamping screw for holders FMH S.FMHxx. - screws for shell mill holders FMH DR.FMH2.xx - drive rings for combi shell mill holders FMH2 F.FMH2 - feather key for combi shell mill holders FMH2 DS.xx.FMH4 - drive shafts for disc milling cutter arbors FMH4 S.DS.xx.FMH4 - screws for drive shaft for disc milling cutter arbors FMH4 S.W.xx - screws for end mill holders Weldon E.MORSE.MT.xx - extractors for Morse tapers CT.HSK.xx - coolant tube for HSK holders K.CT.HSK.xx - wrench (key) for coolant tube for HKS holders VDI.SHIM.xx - shims for VDI holders VDI.NOZZ.xx - nozzles for VDI holders VDI.RS.xx - reduction sleeves for VDI holders form E2 TW.xx - tapers wipers AB.A360.xx - assembly blocks adjustable 360 degree AB.S90.xx - assembly blocks solid 90 degree</p>	<p>Characteristic data and variants description xx - represent characteristic data you can find in catalogue</p> <p>Variant descriptions *.C - with coolant hole *.S - sealed *.C.S - with coolant hole and sealed * - represents previous signs in product description</p>

DIN 69871

ISO 60

MAS 403 BT

DIN 2080

HSK-A

VDI

MORSE



SIMPLY RELIABLE

Jako odborníci můžete sami pouhým pohledem na třísku posoudit kvalitu odvedené práce. Tříška svým čistým a jednoduchým tvarem v sobě nese příběh. Naše tříška je jasný a neměnný ukazatel a proto je naším symbolem. Jsme prostě spolehliví.

Argentina

T: 54 (11) 6777-6777
F: 54 (11) 4441-4467
info.ar@dormerpramet.com

Australia

T: 1300 131 274
F: 1300 809 510
info.au@dormerpramet.com

Brazil

responsible for **Bolivia, Panama, Chile, Paraguay, Colombia, Peru, Costa Rica, Uruguay, Ecuador, Venezuela, Guatemala**
T: +55 11 5660 3000
F: +55 11 5667 5883
info.br@dormerpramet.com

Canada

T: (888) 336 7637
En Français: (888) 368 8457
F: (905) 542 7000
cs.canada@dormerpramet.com

Czech Republic

responsible for export CEE: **Albania, Belarus, Bosnia - Herzegovina, Bulgaria, Croatia, Estonia, Kazakstan, Latvia, Lithuania, Macedonia, Montenegro, Romania, Serbia, Slovenia, Ukraine**
T: +420 583 381 111
F: +420 583 215 401
info.cz@dormerpramet.com

Denmark

T: +46 35 16 52 00
F: +46 35 16 52 90
info.se@dormerpramet.com
Kundtjeneste
T: direkt 808 82106
F: direkt +46 35 16 52 90

Finland

T: +358 205 44 121
F: +358 205 44 5199
Asiakaspalvelu
T: suora 0205 44 7003
F: suora 0205 44 7004
info.fi@dormerpramet.com

France

T: +33 (0)2 47 62 57 01
F: +33 (0)2 47 62 52 00
info.fr@dormerpramet.com

Germany

T: +49 9131 933 08 70
F: +49 9131 933 08 742
info.de@dormerpramet.com

Hungary

T: +36-96 / 522-846
F: +36-96 / 522-847
info.hu@dormerpramet.com

China

T: +86 21 2416 0508
F: +86 21 5442 6315
info.cn@dormerpramet.com

India

T: +91 11 4160 6593
info.in@dormerpramet.com

Italy

solid tools:
T: +39 02 38 04 51
F: +39 02 38 04 52 43
indexable tools:
T: +39 0523 55 19 11
F: +39 0523 55 18 00
info.it@dormerpramet.com

Netherlands

T: +31 10 2080 240
F: +31 10 2080 282
info.nl@dormerpramet.com
responsible for **Austria**
T: +31 10 2080 212
F: +31 10 2080 282
info.at@dormerpramet.com
responsible for **Belgium & Luxembourg**
T: +32 3 440 59 01
F: +32 3 449 15 43
info.be@dormerpramet.com
responsible for **Switzerland**
T: +31 10 2080 212
F: +31 10 2080 282
info.ch@dormerpramet.com

New Zealand

T: +64 800 800 922
F: +64 9 2735857
info.int@dormerpramet.com

Norway

T: +46 35 16 52 00
F: +46 35 16 52 90
info.se@dormerpramet.com
Kundeservice
T: direkt 800 10 113
F: direkt +46 35 16 52 90

Poland

T: +48 32 78-15-890
F: +48 32 78-60-406
info.pl@dormerpramet.com

Russia

T: +7 495 775 10 28
F: +7 (499) 763 38 90
info.ru@dormerpramet.com

Slovakia

T: +421 417 645 659
F: +421 417 637 449
info.sk@dormerpramet.com

Spain

T: +34 935717722
F: +34 935717765
info.es@dormerpramet.com
responsible for **Portugal**
T: +351 21 424 54 21
F: +351 21 424 54 25
info.pt@dormerpramet.com

Sweden

responsible for **Iceland**
T: +46 (0) 35 16 52 00
F: +46 (0) 35 16 52 90
info.se@dormerpramet.com
Kundeservice
T: direkt +46 35 16 52 96
F: direkt +46 35 16 52 90

United Kingdom

responsible for **Ireland**
T: 0870 850 4466
F: 0870 850 8866
info.uk@dormerpramet.com

United States of America

responsible for **Mexico**
T: (800) 877-3745
F: (847) 783-5760
cs@dormerpramet.com

Rest of the World

Dormer Pramet International UK
T: +44 1246 571338
F: +44 1246 571339
info.int@dormerpramet.com

Dormer Pramet International CZ
T: +420 583 381 520
F: +420 583 215 401
info.int.cz@dormerpramet.com